

MAXIM

Power Operational Amplifier

LH0101

General Description

The Maxim LH0101 Power Operational Amplifier delivers up to 5 Amp peak output current. Packaged in a rugged TO-3 case, the LH0101 combines the ease of use and performance of a FET input op amp with the power handling capabilities of a 5 Amp output stage. The output short circuit protection makes this device ideal for driving AC and DC motors, large capacitive loads, and electromagnetic actuators. The output stage virtually eliminates crossover distortion while using little quiescent power.

The LH0101 is a wideband amplifier, with a full power bandwidth of 300kHz and a gain bandwidth of 5MHz. To simplify connection to the LH0101, the output of Maxim's LH0101 is connected to both the case and to pin 4.

Applications

The LH0101 is well suited for applications requiring both standard op amp performance and high current output capability:

- DC Motors
- AC Motors
- Actuators
- Coaxial Cable Drivers
- Programmable Power Supplies

Typical Operating Circuit

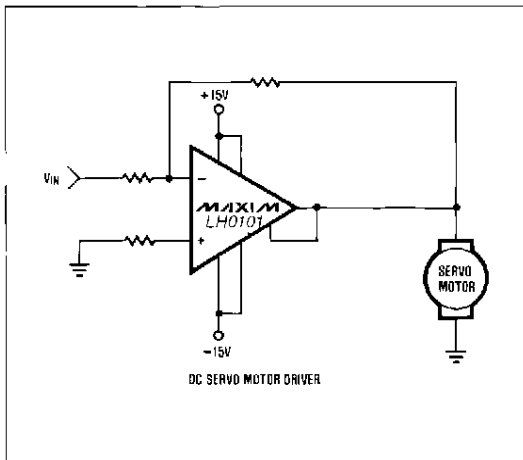

Features

- ◆ Pin for Pin 2nd Source!
- ◆ 5 Amp Peak, 2 Amp Continuous Output Current
- ◆ Virtually No Crossover Distortion
- ◆ 300 kHz Power Bandwidth
- ◆ 300 pA Input Bias Current
- ◆ 10 V/ μ s Slew Rate
- ◆ 5 MHz Gain Bandwidth
- ◆ 2 μ s Settling Time to 0.01%
- ◆ Adjustable Current Limit

Ordering Information

PART	TEMP RANGE	PACKAGE
LH0101CK	-25°C to +85°C	8 Lead TO-3
LH0101K	-55°C to +125°C	8 Lead TO-3
LH0101ACK	-25°C to +85°C	8 Lead TO-3
LH0101AK	-55°C to +125°C	8 Lead TO-3

Pin Configuration

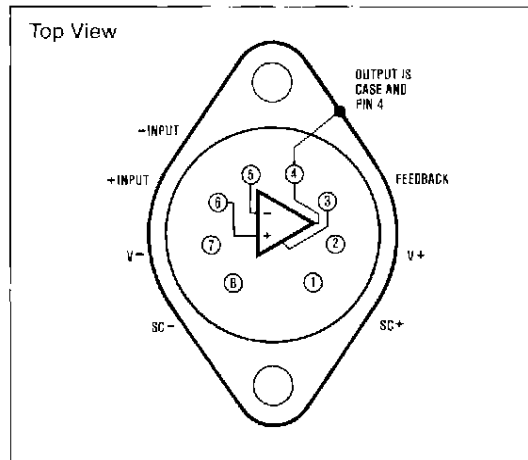

MAXIM

Maxim Integrated Products 1

For free samples & the latest literature: <http://www.maxim-ic.com>, or phone 1-800-998-8800

Power Operational Amplifier

ABSOLUTE MAXIMUM RATINGS

Supply Voltage, V_S	$\pm 22V$	Output Short Circuit Duration (within rated power dissipation, $R_{SC} = 0.35\Omega$, $T_A = 25^\circ C$)	Continuous
Power Dissipation at $T_A = 25^\circ C$	5W	Operating Temperature Range	
Derate linearly at $25^\circ C/W$ to zero at $150^\circ C$		LH0101AC, LH0101C	$-25^\circ C$ to $+85^\circ C$
Power Dissipation at $T_C = 25^\circ C$	62W	LH0101A, LH0101	$-55^\circ C$ to $+125^\circ C$
Derate linearly at $2^\circ C/W$ to zero at $150^\circ C$		Storage Temperature	$65^\circ C$ to $-160^\circ C$
Differential Input Voltage, V_{IN}	$\pm 40V$ but $\leq \pm V_S$	Maximum Junction Temperature	$150^\circ C$
Input Voltage Range, V_{CM}	$\pm 20V$ but $\leq \pm V_S$	Lead Temperature (Soldering, ≤ 10 seconds)	$300^\circ C$
Peak Output Current (50ms pulse)	5A		

Stresses above those listed under "Absolute Maximum Ratings" may cause permanent damage to the device. These are stress ratings only and functional operation of the device at these or any other conditions above those indicated in the operational sections of the specifications is not implied. Exposure to absolute maximum rating conditions for extended periods may affect device reliability.

DC ELECTRICAL CHARACTERISTICS

($V_S = \pm 15V$, $T_A = 25^\circ C$ unless otherwise noted, see Note 1)

PARAMETER	SYMBOL	CONDITIONS	LH0101AC, LH0101A			LH0101C, LH0101			UNITS	
			MIN.	TYP.	MAX.	MIN.	TYP.	MAX.		
Input Offset Voltage	V_{OS}	$T_A = 25^\circ C$		1	3		5	10	mV	
		$T_{MIN} \leq T_A \leq T_{MAX}$ (Note 4)			7			15	mV	
Change in Input Offset Voltage with dissipated power	$\frac{\Delta V_{OS}}{\Delta P_D}$	(Note 2)		150			300		$\mu V/W$	
Change in Input Offset Voltage with temperature	$\frac{\Delta V_{OS}}{\Delta T}$	$V_{CM} = 0$		10			10		$\mu V/^\circ C$	
Input Bias Current	I_B	$T_A = 25^\circ C$			300			1000	pA	
		$T_A \leq T_{MAX}$ (Note 4)	LH0101C/AC		60			60	nA	
			LH0101A		300			1000	nA	
Input Offset Current	I_{OS}	$T_A = 25^\circ C$			75			250	pA	
		$T_A \leq T_{MAX}$ (Note 4)	LH0101C/AC		15			15	nA	
			LH0101A		75			250	nA	
Large Signal Voltage Gain	A_{VOL}	$V_{in} = -10V$, $R_L = 10\Omega$	50	200		50	200		V/mV	
Output Voltage Swing	V_O	$R_{SC} = 0\Omega$, $R_L = 100\Omega$	-11.7	+12.5		-11.7	+12.5		V	
		$A_V = +1$, $R_L = 10\Omega$	-11	+11.6		-11	+11.6		V	
		(Note 3), $R_L = 5\Omega$	+10.5	+11		+10.5	+11		V	
Common Mode Rejection Ratio	CMRR	$\Delta V_{IN} = 10V$	85	100		85	100		dB	
Power Supply Rejection Ratio	PSRR	$\Delta V_S = +5V$ to $-15V$	85	100		85	100		dB	
Quiescent Supply Current	I_S			28	35		28	35		mA

Power Operational Amplifier

LH0101

AC ELECTRICAL CHARACTERISTICS

($V_S = \pm 15V$, $T_A = 25^\circ C$; see Note 1)

PARAMETER	SYMBOL	CONDITIONS	LH0101AC, LH0101A			LH0101C, LH0101			UNITS
			MIN.	TYP.	MAX.	MIN.	TYP.	MAX.	
Equivalent Input Noise Voltage	e_n	$f = 1kHz$		25			25		nV/\sqrt{Hz}
Input Capacitance	C_{IN}	$f = 1MHz$		3.0			3.0		pF
Power Bandwidth, 3dB				300			300		kHz
Slew Rate (Note 4)	SR	$R_L = 10\Omega$	75	10			10		$V/\mu s$
Small Signal Rise or Fall Time	t_r, t_f	$A_V = +1$		200			200		ns
Small Signal Overshoot				10			10		%
Gain-Bandwidth Product (Note 4)	GBW		4.0	5.0			5.0		MHz
Large Signal Settling Time to 0.01%	t_s	$R_L = \infty$		2.0			2.0		μs
Total Harmonic Distortion	THD	$P_O = 0.5W, f = 1kHz$ $R_L = 10\Omega$		0.008			0.008		%

Note 1: Specification is at $T_A = 25^\circ C$. When supply voltages are $\pm 15V$, quiescent operating junction temperature will rise approximately $20^\circ C$ without heat sinking. Accordingly, V_{OS} may change 0.5mV and I_B and I_{OS} will change significantly during warmup. Refer to the I_B vs temperature and power dissipation graphs for expected values. Temperature tests are made only at extremes.

Note 2: Change in offset voltage with dissipated power is due entirely to average device temperature rise and not to differential thermal feedback effects. Test is performed without any heat sink.

Note 3: At light loads, the output swing may be limited by the second stage rather than the output stage. See the application section under "Output swing enhancement" for hints on how to obtain extended operation.

Note 4: These parameters are sample tested to 10% LTPD.

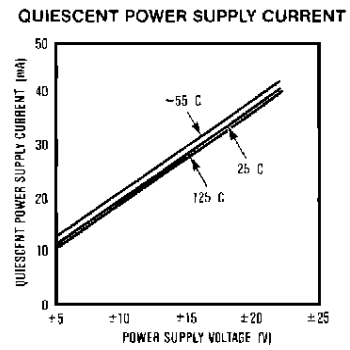
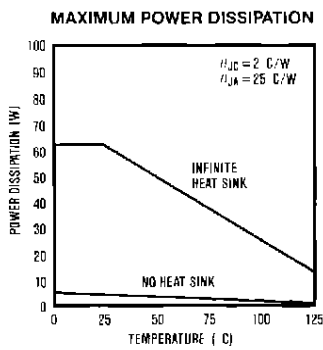
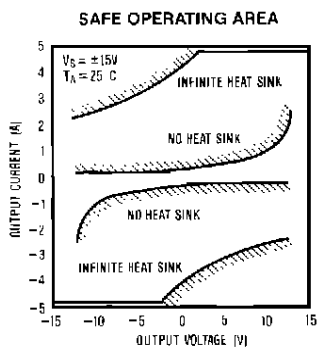

Power Operational Amplifier

LHO101

INPUT COMMON-MODE VOLTAGE RANGE

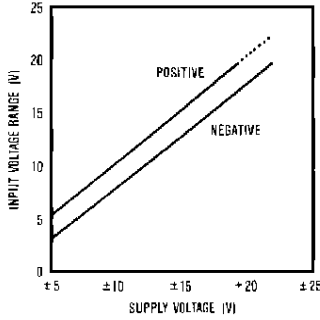

INPUT BIAS CURRENT

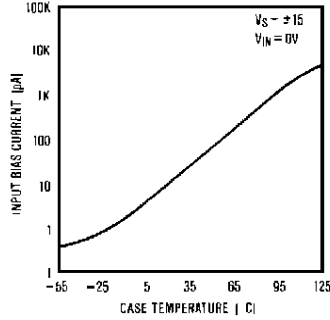

INPUT BIAS CURRENT AFTER WARM-UP

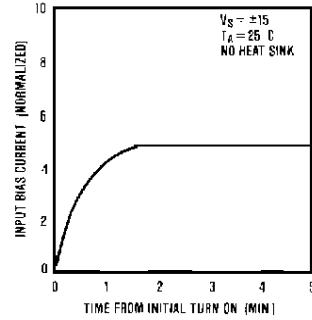

INPUT BIAS CURRENT VS. COMMON-MODE VOLTAGE

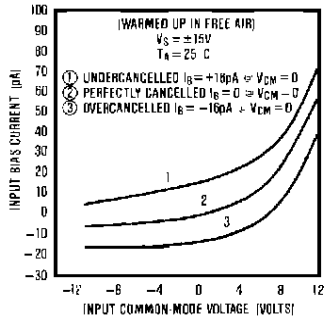

EQUIVALENT INPUT NOISE VOLTAGE

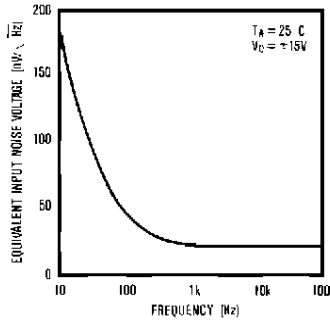

TOTAL HARMONIC DISTORTION VS. GAIN

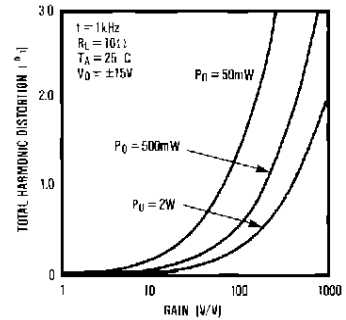

COMMON-MODE REJECTION RATIO VS. FREQUENCY

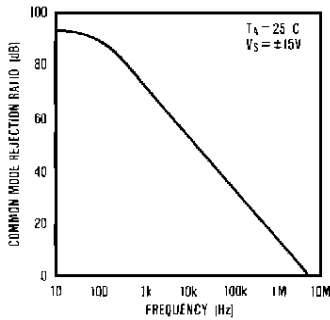

POWER SUPPLY REJECTION RATIO VS. FREQUENCY

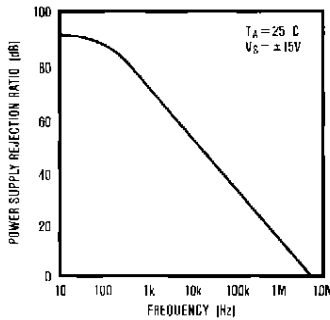

TOTAL HARMONIC DISTORTION VS. FREQUENCY

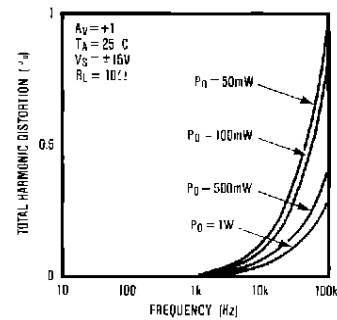

Power Operational Amplifier

LH0101

SMALL SIGNAL PULSE RESPONSE (NO LOAD)

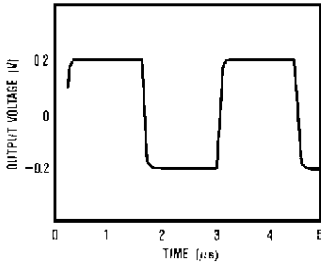

LARGE SIGNAL PULSE RESPONSE ($R_L = 10\Omega$)

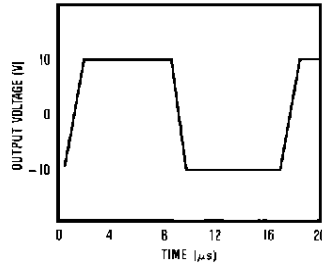

SMALL SIGNAL FREQUENCY RESPONSE (OPEN LOOP)

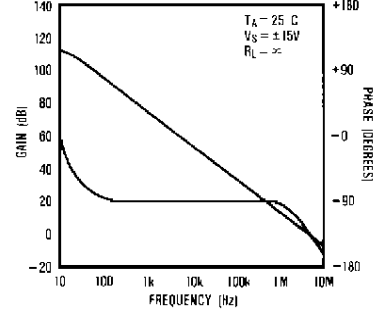

OPEN-LOOP OUTPUT RESISTANCE VS. FREQUENCY

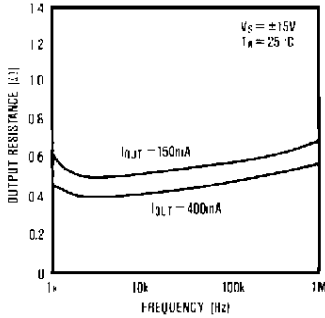

OUTPUT VOLTAGE SWING WITH SWING ENHANCEMENT

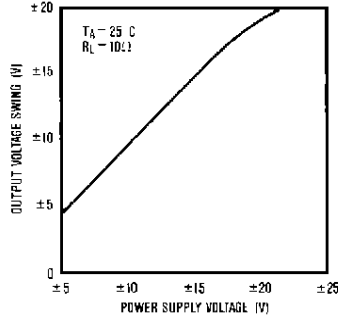

SETTING TIME

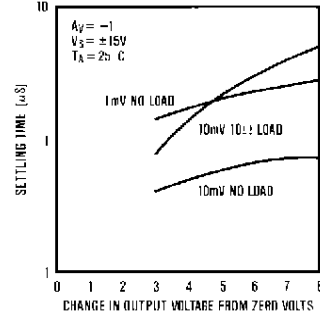

OPEN-LOOP OUTPUT RESISTANCE

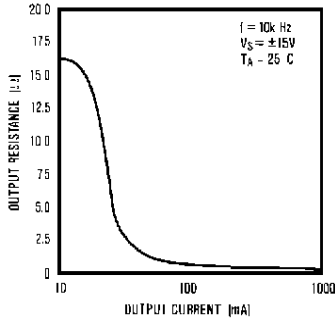

OUTPUT VOLTAGE SWING VS. LOAD RESISTANCE

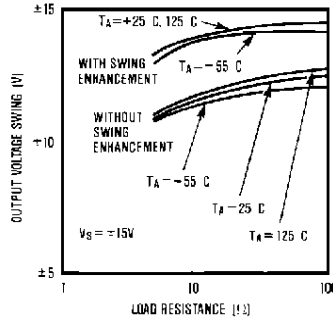

OUTPUT VOLTAGE SWING VS. FREQUENCY

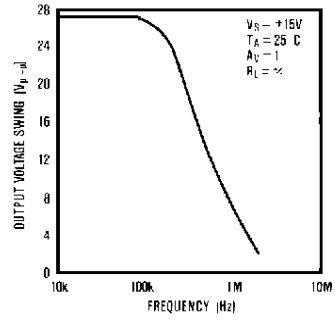

Power Operational Amplifier

Detailed Description

The LH0101 consists of three stages: an operational amplifier, a buffer, and a power output stage. (see Figure 1). The operational amplifier is similar to the LF156. This operational amplifier was chosen for its low bias current, high slew rate, and fast settling time.

The buffer stage, made up of transistors Q3, Q5, Q10, and Q11, is a unity gain current amplifier. The buffer stage bandwidth is greater than 50MHz, and is current limited to 50mA output by the JFETs Q8 and Q7. If the Feedback pin is connected to the Output, the buffer stage provides all output current up to 25mA. The buffer stage current flows through the 50Ω resistors, R3 and R4. The voltage across these resistors turns on the high power output stage when the buffer stage output current is approximately 25mA. The buffer stage continues to supply current up to its 50mA current limit during the turn-on delay of the output stage. Only in driving low resistance or high capacitance loads at high frequencies will there be any noticeable distortion during the period when the output stage is turning on.

The high power output stage consists of the power darlings, Q1 and Q2, and the current limit protection circuit. The power darlington transistors are die attached directly to the case, minimizing thermal resistance. This electrically connects the collectors of Q1 and Q2 to the case, therefore the case is the LH0101 Output connection. The output of the Maxim LH0101 is also connected to pin 4. This additional output connection enables users to make all connections directly via

socket or printed circuit board, without having to make the output connection through heatsink mounting hardware.

Transistors Q6 and Q9 provide current limit protection. The current limit threshold is programmed by sense resistors connected between the supplies and the short circuit protection pins, SC⁺ and SC⁻. A voltage of about 0.6V across the sense resistors turns on either Q6 (source current limit) or Q9 (sink current limit). These transistors then turn on Q12 or Q4, which divert excess base current drive away from the darlington output transistors, preventing the output current from rising beyond the preset limit.

Application Hints

Output Swing Enhancement

When the Feedback terminal is directly connected to the Output, the buffer stage clips and limits the output voltage swing before the output stage saturates. The output swing is 11V to 12.5V with the Feedback terminal connected to the Output. The output swing can be increased by using the circuit of Figure 2. In this circuit the output stage operates with a gain of 1.5 and the output stage saturation voltage of approximately 1V limits the output voltage swing. The 0.01μF compensation capacitor is required for loop stability in unity gain non-inverting buffer applications using output swing enhancement, but is not needed in circuits with a closed loop gain greater than 1.5.

Capacitive Loads

Capacitive loads create an additional pole with the associated phase shift, which may cause oscillations. The LH0101 typically has 60° of phase margin as a unity gain buffer with no capacitive load. A 1000pF load will reduce this phase margin to 40° and 0.01μF will reduce it to only 22°. A phase margin of only 22° is generally considered unacceptably low and the LH0101 should

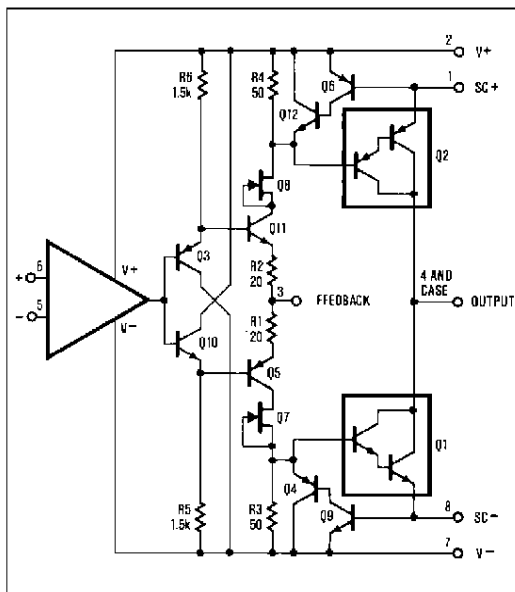

Figure 1. Maxim LH0101 Schematic.

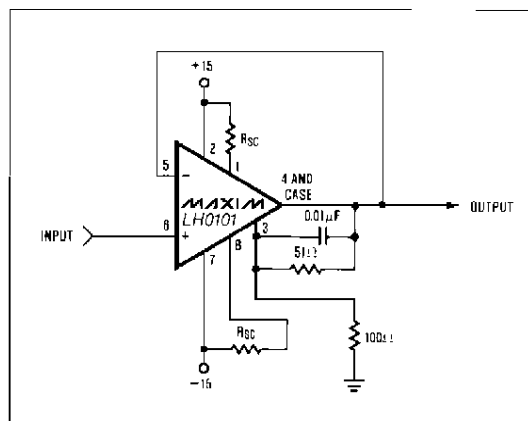

Figure 2. High Power Voltage Follower with Swing Enhancement.

Power Operational Amplifier

LH0101

be compensated as shown in Figure 3 when driving capacitive loads in the $0.01\mu\text{F}$ range. Figure 4 shows an alternative method of compensation which can easily be used with the output swing enhancement circuit discussed below.

As with most amplifiers, there is a value of load capacitance above which oscillation will not occur. For the LH0101 this value is approximately $0.1\mu\text{F}$. The pole formed by the LH0101 output impedance and capacitive loads greater than $0.1\mu\text{F}$ becomes the dominant pole and oscillation will not occur. In summary, if the load capacitance is less than 1000pF or greater than $0.1\mu\text{F}$ the circuit should be stable, otherwise use the compensation techniques of Figure 3 or 4.

Inductive Loads

Inductive loads present three potential problems: inductive kickback or back EMF, stability, and safe

operating area (SOA) violations. The LH0101 is suitable for driving inductive loads such as voice coil actuators and motors, but many circuits will require protection from the harmful effects of the energy stored in the inductor. The inductive kickback problem occurs when the power to the circuit is removed while high current is still flowing through the inductor. The back EMF or inductive kickback may have enough energy to destroy the LH0101 as current flows from the inductive load, through the output stage, back into the internal circuitry of the LH0101. The clamp diodes shown in Figure 5 will steer the inductive kickback currents directly to the power supplies, thus protecting the LH0101.

Some inductive loads, particularly those with high Q, may cause spurious oscillations. The damping circuit shown in Figure 6, a series combination of 10Ω and $0.01\mu\text{F}$ or $0.1\mu\text{F}$, usually cures this type of problem.

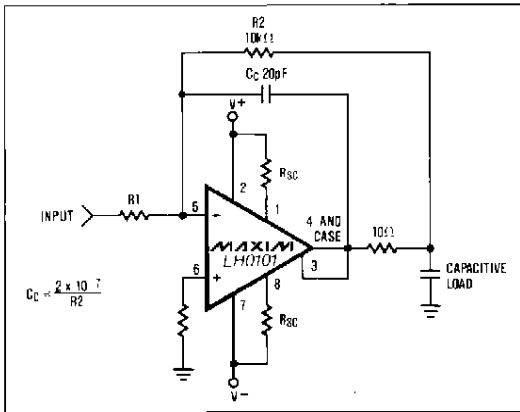

Figure 3. Compensation for Capacitive Load.

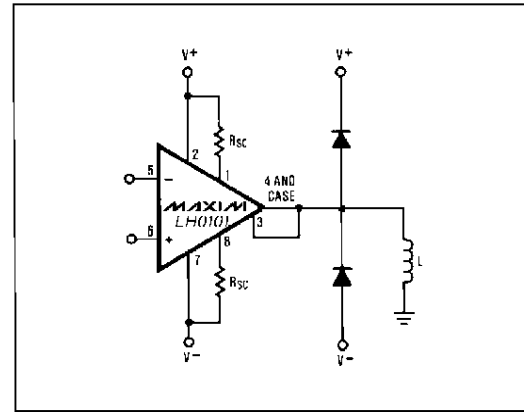

Figure 5. Back EMF Suppression.

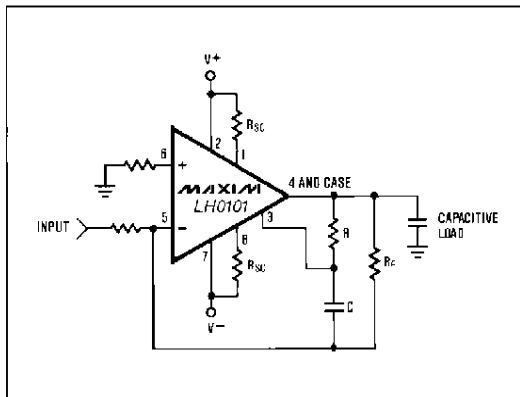

Figure 4. Alternate Compensation for Capacitive Load

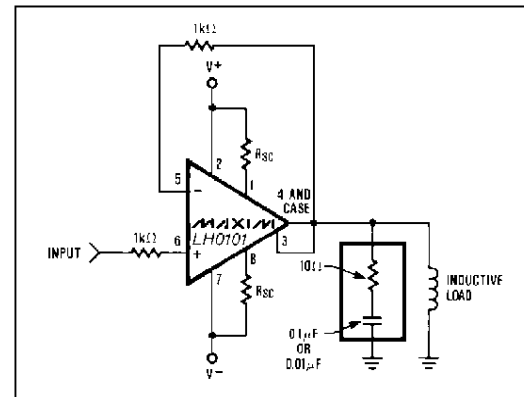

Figure 6. Damping of High Q Inductive Load.

Power Operational Amplifier

Printed Circuit Board Layout and Kelvin Connections or Remote Sensing

Printed circuit board traces which carry high currents must be carefully designed. High current traces must of course be wide enough to handle the current without excessive heating. A 0.030" wide trace on 2oz./ft² copper clad board will have a 10°C rise when carrying 3 Amp. Even when the printed circuit board traces are large enough to carry the current, the voltage drops may cause errors in the output. For example, a 0.030" wide trace on a 2oz. copper clad board will have a resistance of 10mΩ per inch of length and will have a voltage drop of 20mV/inch when carrying 2 Amp. Errors due to voltage drops can be avoided by using one trace or conductor for high current output connections and a second trace or conductor for the low current feedback sensing connection. Figure 7 shows the proper configuration of supply and feedback connections. The 470Ω resistor completes the feedback path if the remote sense connection is inadvertently disconnected.

In some cases signal ground and the power ground are connected together elsewhere and cannot be connected as shown in Figure 7. In this case the circuit of Figure 8 can be used. If $R_{SG}/R_{PG} = R_i/R_f$, voltage drops across R_G are turned into a common mode voltage at the input of the LH0101 and are rejected by the 100dB common mode rejection ratio (CMRR) of the LH0101.

Supply Bypassing

The LH0101 must be adequately bypassed to avoid oscillation and stability problems caused by the power supply impedance. The higher currents and lower

impedance levels associated with the LH0101 require more bypassing than is normally required for lower power op amps. A 0.1μF ceramic capacitor in parallel with at least 47μF is recommended. The minimum acceptable bypassing is 0.01μF in parallel with 4.7μF between ground and each power supply.

Common Mode Voltage Range

While the common mode rejection ratio (CMRR) is guaranteed only over the ±10V input voltage range, the actual input common mode voltage range (CMVR) is typically -12V to +15.1V with ±15V power supplies.

Exceeding the negative common mode limit on either input will cause a phase reversal; if the inverting input exceeds the negative common mode limit the output will be forced low; if the non-inverting input exceeds the negative common mode limit the output will be forced high.

Exceeding the positive common mode limit on only one input will not cause a phase reversal. Exceeding either the positive or the negative common mode limit with both inputs will force the output high.

The LH0101 does not latch-up when the inputs exceed the common mode voltage range provided the absolute maximum ratings are not exceeded; normal operation resumes when the inputs return to within the common mode voltage range limits.

Input Protection

While the very low input bias current specification of the LH0101 might appear to eliminate the need for a bias compensation resistor at the non-inverting input,

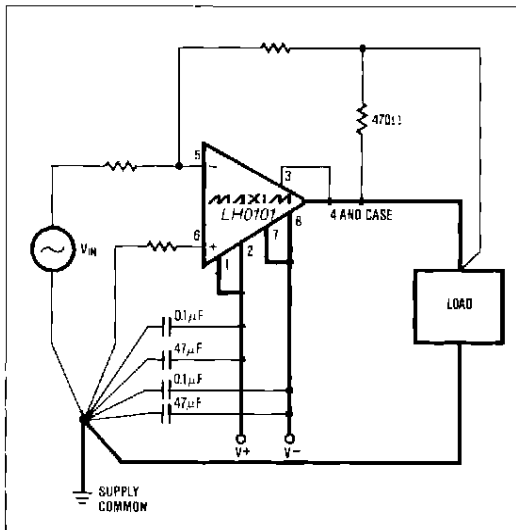

Figure 7 Power Supply Connections

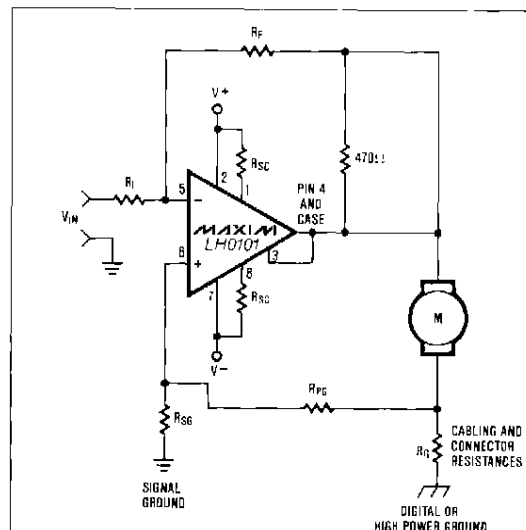

Figure 8 Correcting for Voltage Difference between Signal and Power Grounds.

Power Operational Amplifier

LH0101

the bias compensation resistor also protects this input. Direct connection of the inputs to ground should be avoided since excessive fault currents might flow if one of the power supplies were to be interrupted. A 1k Ω or greater resistor in series with the inputs will avoid this potential problem.

Heatsinks and Power Dissipation Limits

The maximum junction temperature of the LH0101 is 150°C. This is the basic limitation that, in conjunction with the thermal resistance, sets the maximum allowable power dissipation for the LH0101. Specifically,

$$P_{DISS(MAX)} = \frac{T_{J(MAX)} - T_A}{\theta_{JC} + \theta_{CS} + \theta_{SA}}$$

Where

$T_{J(MAX)}$ is the maximum allowable junction temperature of the LH0101, 150°C.

T_A is the ambient temperature.

θ_{JC} is the LH0101 junction to case thermal resistance, 2°C/W.

θ_{CS} is the thermal resistance between the LH0101 case and the heatsink in °C/W.

θ_{SA} is the thermal resistance from the heatsink to ambient.

The θ_{JC} of the LH0101 is typically 2°C/W; a conservative design should use a value of 2.5°C/W to allow for device-to-device variations in θ_{JC} . The actual power dissipation in a given application is the sum of the quiescent power dissipation (850mW typical with $\pm 15V$ power supplies) and the power dissipation in the output transistors. The dissipation in the output transistors is the time average of the instantaneous product of the output current times the voltage difference between the output and the supply voltage.

Short Circuit Current Limiting

The source and sink current limits are individually set by the current sense resistors connected between the power supplies and the short circuit current limit pins, SC⁺ and SC⁻. Calculate the resistor values from the formula.

$$I_{SHORT\ CIRCUIT} = \frac{0.6V}{R_{SC}}$$

This equation is only an approximation, and it is not unusual for the actual current limit to vary as much as 25% from the expected value. The 0.6V in the above formula is the V_{BE} of Q6 and Q9, which may vary as much as 10% from device to device. This V_{BE} also has a temperature coefficient of about -2mV/°C. A second error source is the exact value of R_{SC} . Remember that R_{SC} includes all resistance between the power supply and the SC terminal, including printed circuit board trace resistance, solder joints, and if a socket is used, the socket contact resistance. Since R_{SC} may be as low

as 0.12 Ω , these extra resistances can be a significant fraction of the total R_{SC} . The power dissipation of the current limit resistor is:

$$P_{DISS} = \frac{(0.6V)^2}{R_{SC} \text{ (in } \Omega)} = \frac{0.36}{R_{SC}} \text{ Watts}$$

When the LH0101 is used without a heatsink, set the current limit to 250mA with 2.7 Ω resistors for R_{SC} .

Safe Operating Area

The Safe Operating Area curve shown in the typical characteristics section must not be exceeded. This curve is for a case temperature of 25°C, and must be further derated for operation at elevated case temperatures.

There are two basic limits that must be observed; the maximum current limit and the maximum power dissipation limit. The SOA curve does not have any limits set by secondary breakdown in the output transistors, the power dissipation limit is reached before the transistors approach their secondary breakdown limits.

Table 1. HEATSINKS FOR LH0101

Manufacturer	Part #
Thermalloy	6002-19
IERC	LAIC3B4CB HPI-TQ3-33CR

Table 2. SOCKETS FOR LH0101

Manufacturer	Part #	Comments
Robinson Nugent Inc.	000201*	Chassis or heat-sink mounted socket
Midland-Ross	450-3716-01-03-00	Low cost socket pins for PCB mounting
Hypertronics	YSK0102-004	8 socket pins are required to mount one LH0101

Hypertronics
16 Brent Dr
Hudson, MA 01749
(617) 568-0451

IERC
135 W Magnolia Bl.
Burbank, CA 91502
(818) 786-1182

Midland-Ross
Cambion Div
445 Concord Ave
Cambridge, MA 02238
(617) 491-5400

Robinson Nugent Inc.
800 E. 8th St.
New Albany, IN 47150
(812) 945-0211

Thermalloy
P.O. Box 34829
Dallas TX 75234
(214) 243-4321

Power Operational Amplifier

Typical Applications DC Servomotor Amplifiers

Figure 10 shows a voltage feedback DC servomotor amplifier. This type of control loop is normally used when the speed control is achieved by controlling the motor voltage. With the resistor values shown, the voltage at the motor will be $-5 \times V_{IN}$. The output voltage is sensed at the motor, therefore voltage drops in the cable between the LH0101 and the motor will not affect the voltage applied to the motor. The 10Ω resistor and $0.01\mu\text{F}$ capacitor may be required to prevent oscillations.

Figure 11 shows a current feedback DC servomotor amplifier. This type of control loop is normally used to develop a torque approximately proportional to the input voltage. Like Figure 9 this circuit delivers a constant current that is proportional to the input voltage.

Figure 12 combines both current and voltage feedback to achieve better open loop speed regulation than can be achieved by either Figure 10 or 11. The specific values of R_S , R_{FI} and R_{GI} are chosen to best approximate the Speed/Current/Torque characteristic of the motor. Capacitor C_C may be required for stability if the

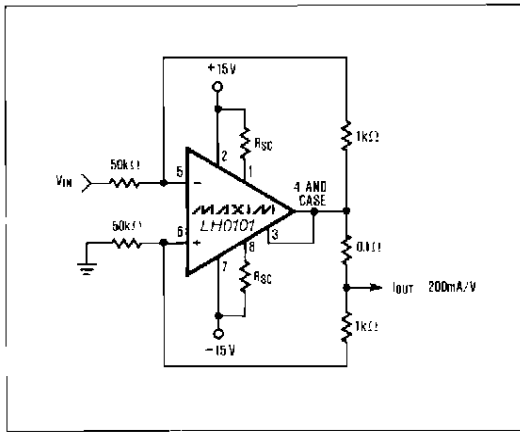

Figure 9. High Current Source (Sink).

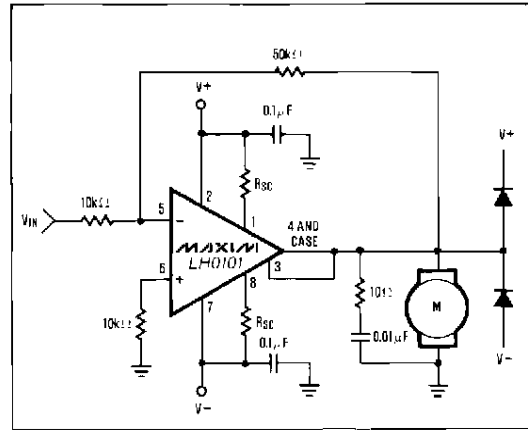

Figure 10. Servo Motor Amplifier.

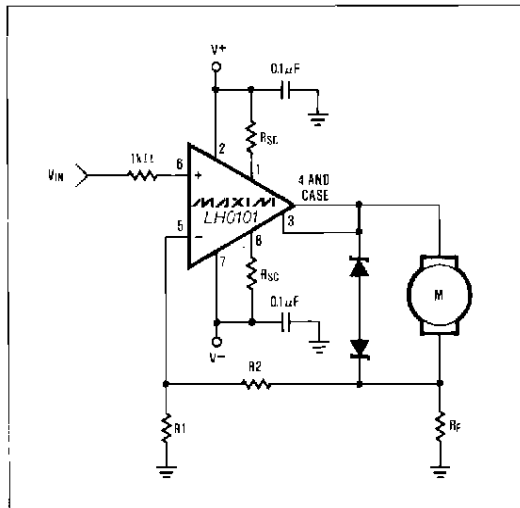

Figure 11. Torque Feedback Servo Motor Amplifier

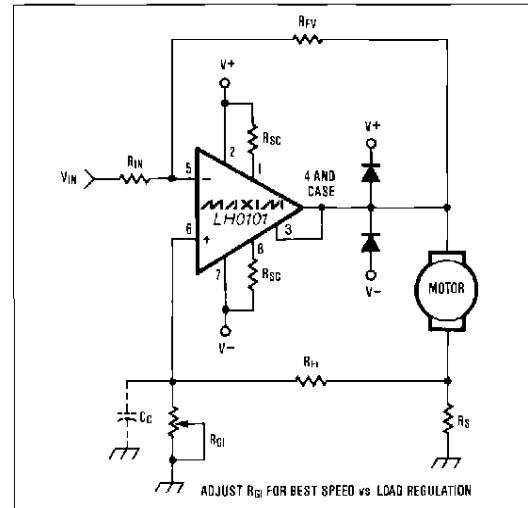

Figure 12 Constant Speed Motor Driver

Power Operational Amplifier

LH0101

positive feedback is such that the motor speed increases with increased torque load.

These circuits will either source or sink current, depending on the polarity of the input voltage, and can drive DC motors in both directions.

Low Distortion Audio Amplifier

The hermetically packaged LH0101 is well suited for use as an audio amplifier for severe environments. Figure 13 shows two LH0101s used in a bridge audio power amplifier. The bridge configuration doubles the voltage that can be delivered to the load, in this case delivering 50V peak-peak to an 8Ω speaker. This means that a 40 Watts RMS can be delivered to the 8Ω speaker while using only ±18V power supplies. The harmonic distortion is a respectable 0.1%, which should suffice for all but the most demanding applications.

CRT Yoke Driver Circuit

The 300kHz power bandwidth and 5 Amp peak output current capability of the LH0101 make it well suited for CRT yoke driver circuits such as Figure 14. This circuit is basically a constant current source/sink with a transconductance of 435 mA/V (reciprocal of the 2.3Ω current sense resistor). The resistor R_{DAMP} lowers the Q of the inductive yoke; the value of R_{DAMP} is chosen empirically for the least distortion at the operating frequency. At low frequencies R_{DAMP} is not required.

DC Servomotor Phase Locked Loop

In the circuit of Figure 15, the shaft encoder produces 600 pulses per revolution. These pulses are compared to a reference frequency by the digital phase comparator of the CD4046. The output of the phase comparator passes through a low pass filter and drives the input of the LH0101. The LH0101 amplifies this signal and drives the DC servomotor. The phase-frequency comparator of the CD4046 increases or decreases the input voltage to the LH0101 until the shaft encoder output is the same frequency as the reference input.

$$\text{Motor Speed (in RPM)} = \frac{F_{IN} \times 60}{N}$$

Where F_{IN} is the frequency of the reference input and N is the number of shaft encoder pulses per revolution.

A single-pulse-per-revolution speed pickup can be used in place of the shaft encoder, but the PLL low pass filter time constant must be greatly increased.

Note that this circuit is similar to a standard phase locked loop except that the LH0101, the motor, and the shaft encoder replace the internal VCO of the CD4046. Unlike the VCO of the CD4046, the motor adds another pole to the system response and loop stability must be carefully analyzed, particularly if the motor and its load has significant inertia. As with most feedback systems, the loop will be stable when there is only one dominant pole. The loop filter time constant should preferably be at least 1 decade higher or lower than the constant of the motor and its load.

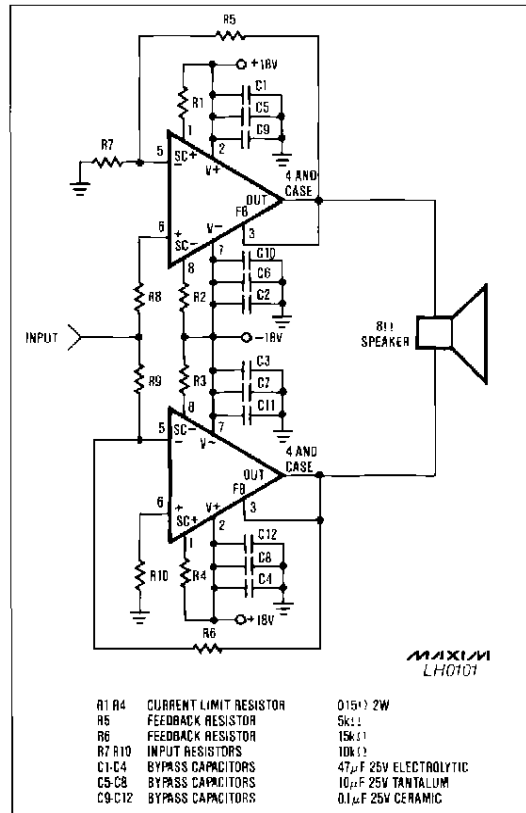

Figure 13. LH0101 Bridge Audio Power Amplifier.

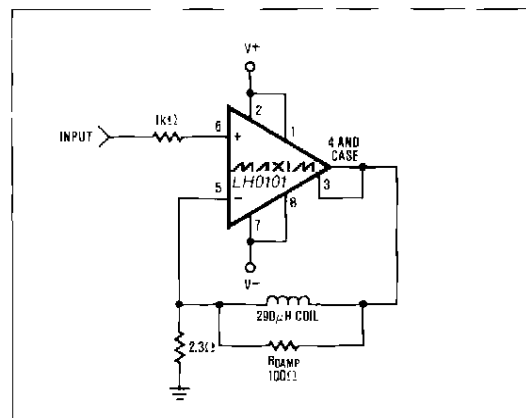

Figure 14. CRT Yoke Driver Circuit.

Power Operational Amplifier

LH0101

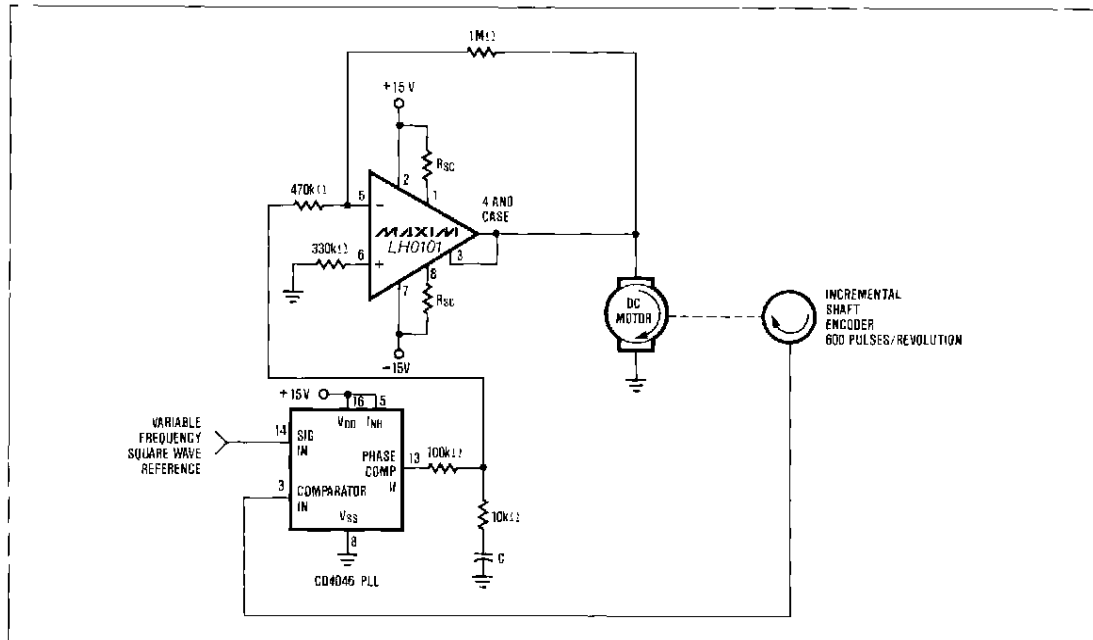
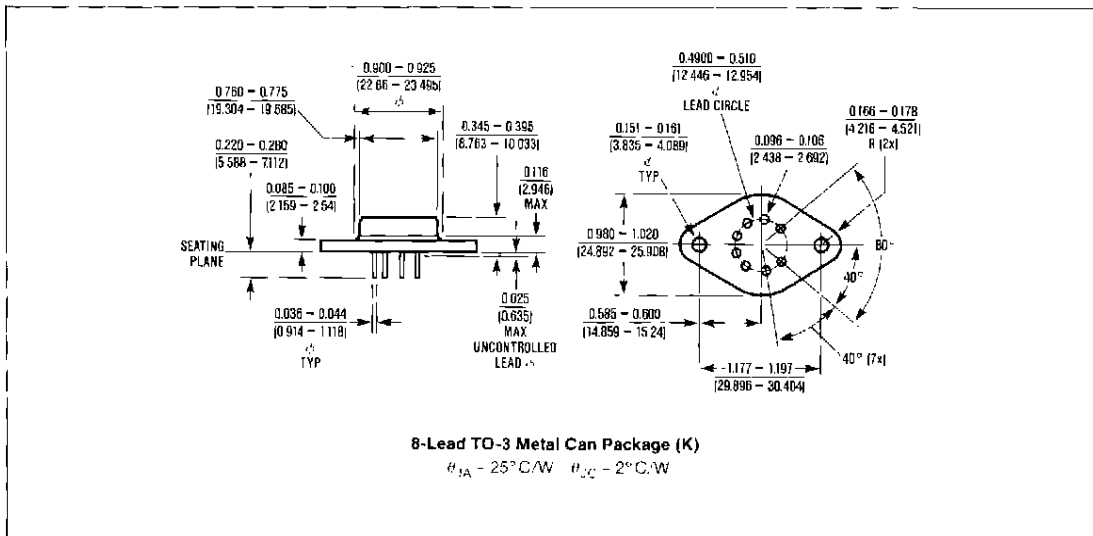

Figure 15. Servomotor Phase Locked Loop.

Package Information



Maxim cannot assume responsibility for use of any circuit other than that shown, entirely enclosed in a Maxim product. No circuit patent licenses are implied. Maxim reserves the right to change the circuitry and specifications without notice at any time.

12 Maxim Integrated Products, 120 San Gabriel Drive, Sunnyvale, CA 94086 (408) 737-7600

© 1996 Maxim Integrated Products Printed USA MAXIM is a registered trademark of Maxim Integrated Products.