



ANATECH ELECTRONICS INC
RF & Microwave Filters & Products

217.775 MHz Bandpass Filter

Part Number: AE217B10998



Electrical specifications

Center Frequency: 217.775 MHz
Passband Ripple: <0.1 dB
Return Loss at Center Frequency: >1.5
Insertion Loss: <1.2dB
Input / Output Impedance: 50 Ohms
Rejection: >30dB @ 0-200 MHz
Rejection 2: >30dB @ 234-600 MHz
Power Handling: 200 W

Mechanical

Dimensions: 4 x 1.25 x 0.75 inches
Connector Type: N-Type

Environmental

Operating Temperature: -45 to +85 deg. C
Storage temperature: -65 to +95 deg. C
Shock: 20 G's, 1/2 sine, 11ms
Vibration: 10 G's, 10-2000Hz
Relative Humidity: 0-95%

Outline Drawing:

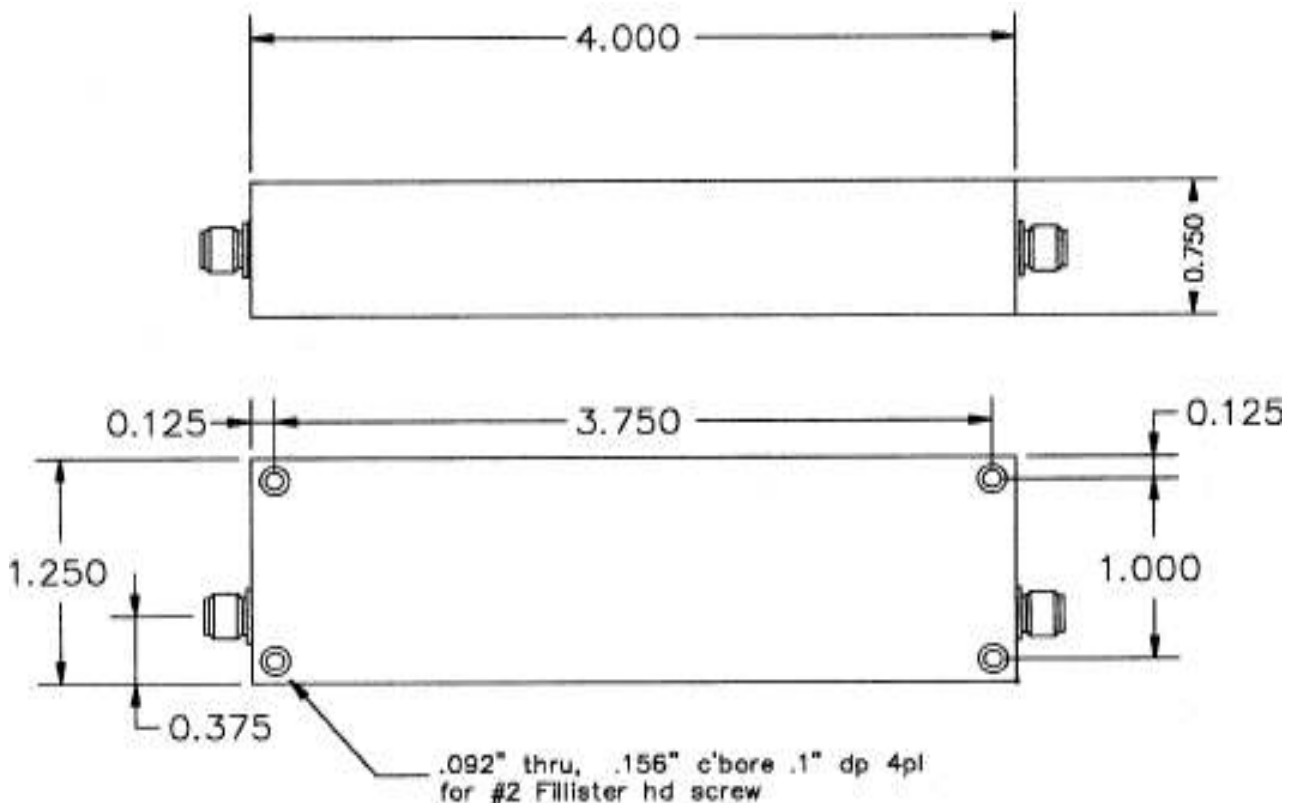



Response Plot:

