



# DIN Signal har-bus 64 female connector



## General information

Design	IEC 61076-4-113	type: har-bus64 female
No. of contacts	max. 160	
Contact spacing	2,54mm	
Test voltage	1000V	
Contact resistance	max. 20mOhm for rows a, b, c	max. 30mOhm for rows d, z
Insulation resistance	min. 10 <sup>10</sup> Ohm	
Working current	1A at 70°C (see derating diagram)	
Temperature range	-40°C ... +105°C (due to limitations of PCB material)	
Termination technology	press-in	

Clearance & creepage	minimum distance	rows a, b, c	rows d, z
		between 2 rows	clearance
		creepage	1,2mm
	between 2 contacts in a row	clearance	1,0mm
		creepage	1,0mm

Insertion and withdrawal force	max. 160N	
PCB thickness	min. 1,6mm	
Mating cycles	PL 1 acc. to IEC 61076-4-113	500 mating cycles
	PL 2 acc. to IEC 61076-4-113	250 mating cycles
UL file	E102079	
RoHS - compliant	Yes	
Leadfree	Yes	

## Insulator material

Material	LCP (Liquid Cristal Polymer)
Colour	nature
UL classification	UL 94-V0
Material group acc. to IEC 60664-1	IIIa (175 ≤ CTI < 400)

## Contact material

Contact material	Copper alloy
Plating termination zone	Ni
Plating contact zone I	Au over Ni
Plating contact zone II (termination side)	Au over Ni

## Derating diagram acc. to IEC 60512-5 (Current carrying capacity)

The current carrying capacity is limited by maximum temperature of materials for inserts and contacts including terminals.

The current capacity curve is valid for continuous, non interrupted current loaded contacts of connectors when simultaneous power on all contacts is given, without exceeding the maximum temperature.

Control and test procedures according to DIN IEC 60512-5

With selective loading higher currents can be transmitted. The requirements according to VITA 1.7 are fulfilled.

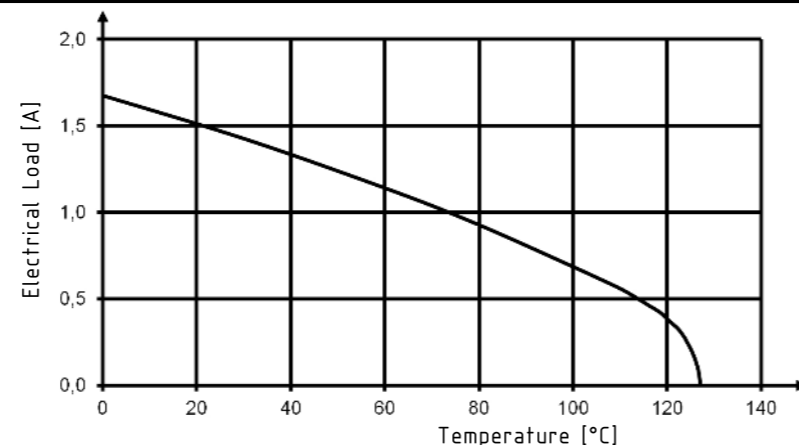

## Recommended configuration of plated through holes for press-in termination

In addition to the hot-air-level (HAL), other PCB surfaces are getting more important. Due to their different properties - such as mechanical strength and coefficient of friction - we recommend the following configuration of PCB through holes.

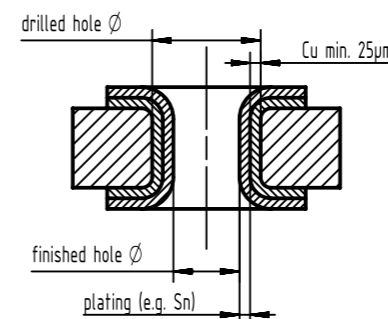

PCB Type	Plating	Drilled hole Ø	Plated hole Ø
Tin plated PCB (HAL) acc. to EN 60352-5	Sn	1,15±0,025 mm	max. 15 µm
			0,94 - 1,09 mm
Chemical tin plated PCB	Sn	1,15±0,025 mm	min. 0,8µm
			1,00 - 1,10 mm
Gold /Nickel plated PCB	Ni	1,15±0,025 mm	3 - 7 µm
	Au		0,05 - 0,12 µm
			1,00 - 1,10 mm
Silver plated PCB	Ag	1,15±0,025 mm	0,1 - 0,3 µm
			1,00 - 1,10 mm
Copper plated PCB (OSP)		1,15±0,025 mm	
			1,00 - 1,10 mm

## Assembly instructions

It is highly recommended to use HARTING press-in tools to ensure a reliable press-in process. Please refer to the catalogue for tools, machines and further information about the press-in process.

	All rights reserved	Created by	Inspected by	Standardisation	Date	State	
	Department EC PD - DE	ZWAHR	TADJE	HOFFMANN	2014-03-06	Final Release	
HARTING Electronics GmbH D-32339 Espelkamp		Title DIN Signal har-bus 64 female connector				Doc-Key / ECM-Nr. 100556621/UGD/001/A 50000068472	
		Type	Number		Rev.	Page	
		DS	02022100102		A	1/1	