

DOUBLE ENDED ASSEMBLY			SINGLE ENDED ASSEMBLY		
PART NUMBER	KEYING OPTION	DIM "A"	PART NUMBER	KEYING OPTION	DIM "A"
171466-2001	A	.50M±20.0MM	171466-1001	A	.50M±20.0MM
171466-2002	B		171466-1002	B	
171466-2011	A	1.0M±30.0MM	171466-1011	A	1.0M±30.0MM
171466-2012	B		171466-1012	B	
171466-2021	A	1.5M±40.0MM	171466-1021	A	1.5M±40.0MM
171466-2022	B		171466-1022	B	
171466-2031	A	2.0M±50.0MM	171466-1031	A	2.0M±50.0MM
171466-2032	B		171466-1032	B	
171466-2041	A	3.0M±50.0MM	171466-1041	A	3.0M±50.0MM
171466-2042	B		171466-1042	B	

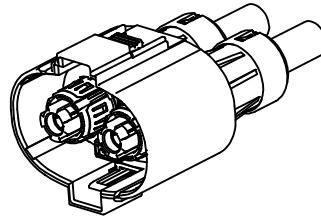

- NOTES:
- MATERIAL:
MAIN HOUSING: PBT UV STABILIZED COLOR: ORANGE
POWER TERMINALS: COPPER
HVIL TERMINALS: COPPER ALLOY
 - FINISH:
POWER TERMINALS: SILVER OVER NICKEL PLATING
HVIL TERMINALS: TIN OVER NICKEL WITH SELECT GOLD PLATING
 - CABLE FOR POWER TERMINALS: CHAMPLAIN EXTRAD-FXS 1/0X WITH EMI SHIELD
 - WIRE FOR HVIL TERMINALS: 18 GAGE TXL STRANDED WIRE
 - MATES WITH HEADER ASSEMBLY SERIES 171467-1***
 - PRODUCT SPECIFICATION: PS-171467-001
 - APPLICATION SPECIFICATION: AS-171467-001

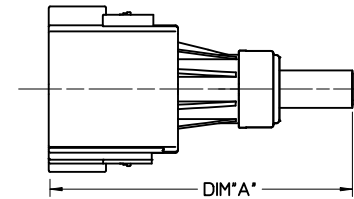

SINGLE ENDED HARNESS ASSEMBLY

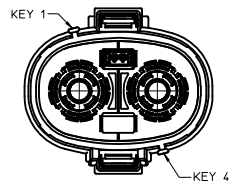

OPTION A
KEYING 1-4
MOLEX STANDARD
KEY VERSION

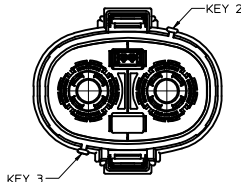

OPTION B
KEYING 2-3

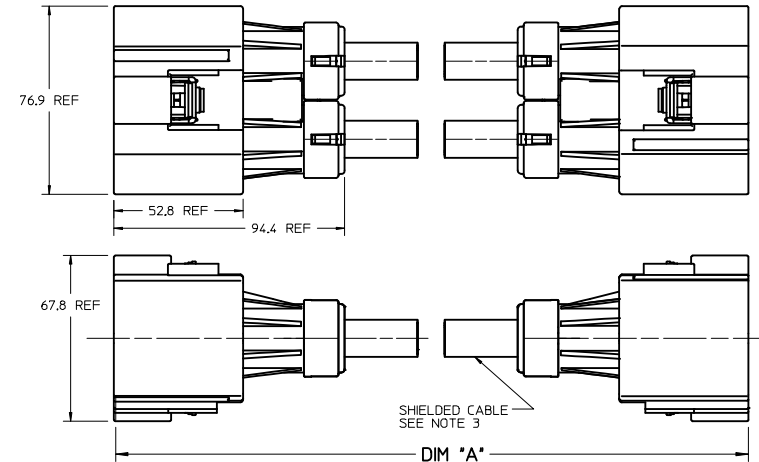
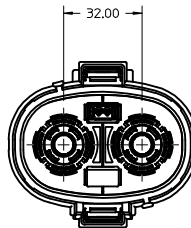

DOUBLE ENDED HARNESS ASSEMBLY

USE OF THIS PRODUCT REQUIRES THAT APPROPRIATE HIGH VOLTAGE WARNING LABELS BE APPLIED TO THE CABLE ASSEMBLY AND/OR IN CLOSE PROXIMITY OF THE MATED CONNECTOR APPLICATION IN A MANNER THAT PROVIDES SUITABLE WARNING TO THE END USER AND MEETS APPLICABLE LAWS. IT IS THE RESPONSIBILITY OF THE OEM OR MANUFACTURER OF THE PRODUCT IN WHICH THIS CONNECTOR SYSTEM IS USED TO APPLY THE APPROPRIATE HIGH VOLTAGE WARNING LABEL(S) TO THE FINAL PRODUCT. TO THE EXTENT MOLEX IS NOT RESPONSIBLE FOR THE FINAL CABLE ASSEMBLY, MOLEX DISCLAIMS ALL WARRANTIES AND LIABILITY THAT RESULT FROM A FAILURE TO PROVIDE AN APPROPRIATE WARNING.

REVISED NOTE EC NO: UCP2015-2891 DRAWN: OUILLES 2015/01/19 CHK: MDATA 2015/01/19 APPR: APATEL 2015/01/29	DESCRIPTION HARNESS ASSEMBLY	QUALITY SYMBOLS	GENERAL TOLERANCES (UNLESS SPECIFIED)	DIMENSION STYLE	SCALE	DESIGN UNITS	THIRD ANGLE PROJECTION													
		$\nabla=0$ $\nabla=0$ $\nabla=0$	<table border="1"> <thead> <tr> <th></th> <th>mm</th> <th>INCH</th> </tr> </thead> <tbody> <tr> <td>4 PLACES</td> <td>±.01</td> <td>±.0004</td> </tr> <tr> <td>3 PLACES</td> <td>±.02</td> <td>±.0008</td> </tr> <tr> <td>2 PLACES</td> <td>±0.60</td> <td>±.0236</td> </tr> <tr> <td>1 PLACE</td> <td>±0.9</td> <td>±.0354</td> </tr> </tbody> </table>		mm	INCH	4 PLACES	±.01	±.0004	3 PLACES	±.02	±.0008	2 PLACES	±0.60	±.0236	1 PLACE	±0.9	±.0354	MM ONLY	1:1
	mm	INCH																		
4 PLACES	±.01	±.0004																		
3 PLACES	±.02	±.0008																		
2 PLACES	±0.60	±.0236																		
1 PLACE	±0.9	±.0354																		
DRAFT WHERE APPLICABLE MUST REMAIN WITHIN DIMENSIONS		MATERIAL NO. SEE CHART SIZE D THIS DRAWING CONTAINS INFORMATION THAT IS PROPRIETARY TO MOLEX INCORPORATED AND SHOULD NOT BE USED WITHOUT WRITTEN PERMISSION		DRAWN BY: MDATA DATE: 2011/12/07 CHECKED BY: MDATA DATE: 2011/12/20 APPROVED BY: APATEL DATE: 2012/04/11		TITLE: HARNESS ASSEMBLY 2 CIRCUIT IMPERIUM MOLEX INCORPORATED DOCUMENT NO. SD-171466-1000														
						SHEET NO. 1 OF 1														

PART NUMBER	KEYING OPTION
171467-1001	A
171467-1002	B

MAIN PANEL SEAL MUST BE FULLY SEATED IN SEAL CAVITY BEFORE ATTACHMENT TO PANEL

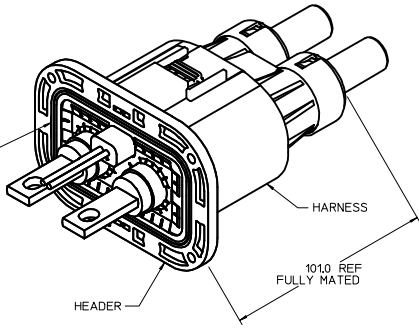

HEADER MATED TO HARNESS

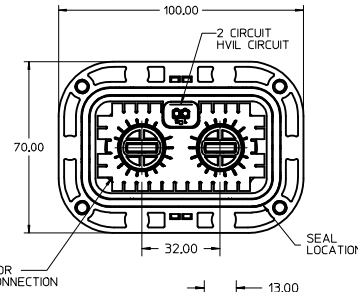
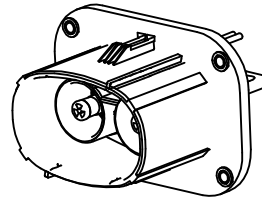

NOTES:

- MATERIAL:
MAIN HOUSING: POLYESTER 94V-0 (OPTIONAL UV STABILIZED)
COLOR: ORANGE
POWER TERMINALS: COPPER
HVIL TERMINALS: COPPER ALLOY
- FINISH:
POWER TERMINALS: SILVER OVER NICKEL PLATING
HVIL TERMINALS: TIN OVER NICKEL PLATING
- WIRE FOR HVIL TERMINALS: 18 GAGE TXL AUTOMOTIVE GRADE STRANDED WIRE
- MATES WITH HARNESS ASSEMBLY SERIES 171466-1***
- ATTACH HEADER WITH SCREWS TO PANEL PER MOLEX APPLICATION SPEC
- PRODUCT SPECIFICATION: PS-171467-001
- APPLICATION SPECIFICATION: AS-171467-001
- PACKAGING SPECIFICATION: PK-171467-999
- SHIELD MATING SURFACE WITHIN THE KEEP OUT ZONE MUST BE A CLEAN SURFACE WITH TIN OR NICKEL PLATING
- BUS BAR AND MOUNTING HARDWARE TO BE OVERALL TIN PLATED

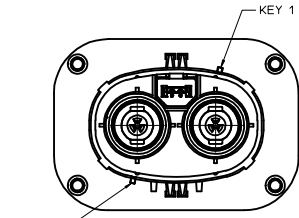

OPTION A
KEYING 1-4
MOLEX STANDARD
KEYIN VERSION

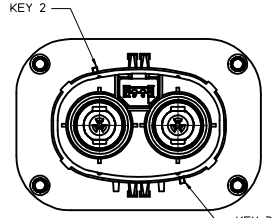

OPTION B
KEYING 2-3

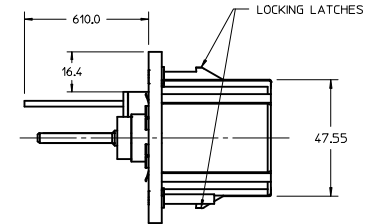
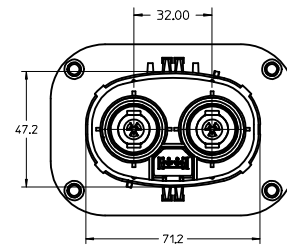
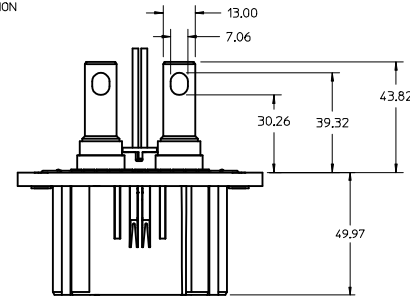

USE OF THIS PRODUCT REQUIRES THAT APPROPRIATE HIGH VOLTAGE WARNING LABELS BE APPLIED TO THE CABLE ASSEMBLY AND/OR IN CLOSE PROXIMITY OF THE MATED CONNECTOR APPLICATION IN A MANNER THAT PROVIDES SUITABLE WARNING TO THE END USER AND MEETS APPLICABLE LAWS. IT IS THE RESPONSIBILITY OF THE OEM OR MANUFACTURER OF THE PRODUCT IN WHICH THIS CONNECTOR SYSTEM IS USED TO APPLY THE APPROPRIATE HIGH VOLTAGE WARNING LABEL(S) TO THE FINAL PRODUCT. TO THE EXTENT MOLEX IS NOT RESPONSIBLE FOR THE FINAL CABLE ASSEMBLY, MOLEX DISCLAIMS ALL WARRANTIES AND LIABILITY THAT RESULT FROM A FAILURE TO PROVIDE AN APPROPRIATE WARNING.

REVISED PIN LOCATION EC NO: UCP2017-1062 DRAWN BY: MDATA CHKD: MDATA APPR: APATEL DESCRIPTION: 2016/10/02 DATE: 2016/10/21	QUALITY SYMBOLS	GENERAL TOLERANCES (UNLESS SPECIFIED)	DIMENSION STYLE	SCALE	DESIGN UNITS	THIRD ANGLE PROJECTION
	▽=0	mm INCH	MM ONLY	1:1	METRIC	☉
	▽=0	4 PLACES ± --- ± ---	DRAWN BY: MDATA	DATE: 2011/12/08	TITLE: HEADER ASSY PANEL MOUNT IMPERIUM	MOLEX INCORPORATED
	▽=0	3 PLACES ± --- ± ---	CHECKED BY: MDATA	DATE: 2011/12/21	DOCUMENT NO: SD-171467-1000	
	2 PLACES ± 0.60 ± ---	DRAFT WHERE APPLICABLE MUST REMAIN WITHIN DIMENSIONS	APPROVED BY: APATEL	DATE: 2012/04/11	THIS DRAWING CONTAINS INFORMATION THAT IS PROPRIETARY TO MOLEX INCORPORATED AND SHOULD NOT BE USED WITHOUT WRITTEN PERMISSION	

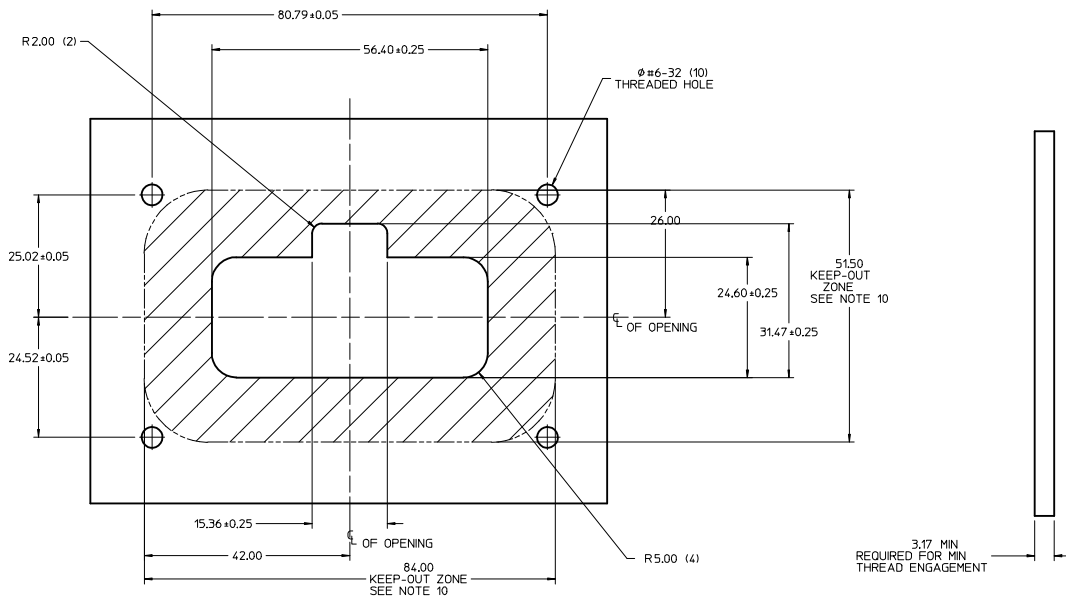

PANEL REQUIREMENTS
SCALE 2:1

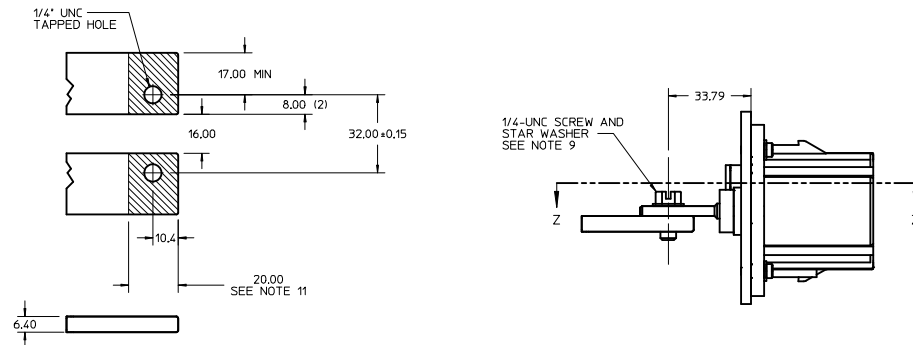

RECOMMENDED BUS BAR DETAIL

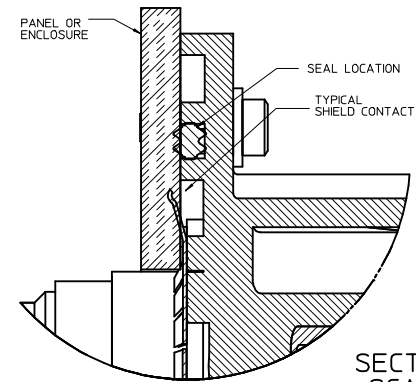
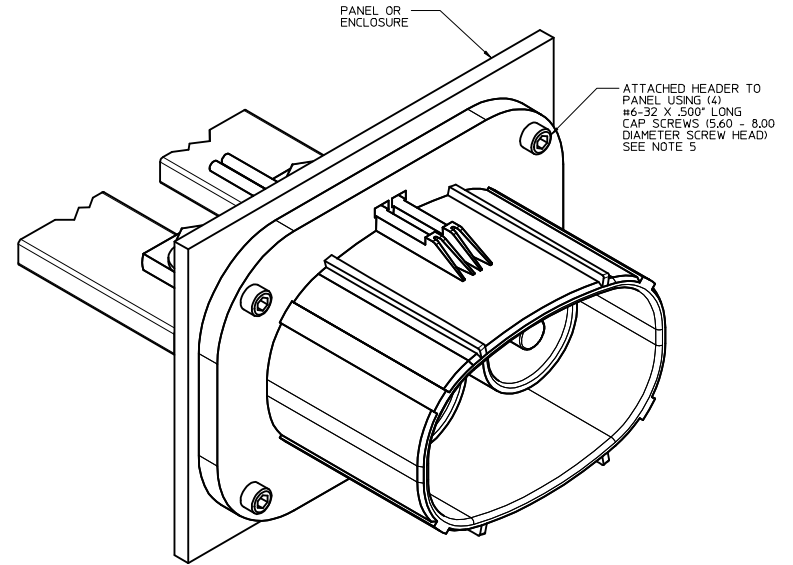

SECTION Z-Z
SCALE 4:1

SEE SHEET 1 IEC NO: UCP2017-1062 DRAWN BY: CHYD APPR: APATEL DATE: 2016/12/21	QUALITY SYMBOLS	GENERAL TOLERANCES (UNLESS SPECIFIED)	DIMENSION STYLE	SCALE	DESIGN UNITS	THIRD ANGLE PROJECTION
	▽=0	mm INCH	MM ONLY	1:1	METRIC	☉
	▽=0	4 PLACES ± --- ± ---	DRAWN BY: MDATA	DATE: 2011/12/08	TITLE: HEADER ASSY PANEL MOUNT IMPERIUM	MOLEX INCORPORATED MATERIAL NO: SD-171467-1000 DOCUMENT NO: SD-171467-1000
	▽=0	3 PLACES ± --- ± ---	CHECKED BY: MDATA	DATE: 2011/12/21	SHEET NO: 2 OF 2	
▽=0	2 PLACES ± 0.60 ± ---	APPROVED BY: APATEL	DATE: 2012/04/11	SIZE: D	THIS DRAWING CONTAINS INFORMATION THAT IS PROPRIETARY TO MOLEX INCORPORATED AND SHOULD NOT BE USED WITHOUT WRITTEN PERMISSION	
	1 PLACE ± 0.90 ± ---	DRAFT WHERE APPLICABLE MUST REMAIN WITHIN DIMENSIONS				

PART NUMBER	KEYING OPTION
171467-1001	A
171467-1002	B

MAIN PANEL SEAL MUST BE FULLY SEATED IN SEAL CAVITY BEFORE ATTACHMENT TO PANEL

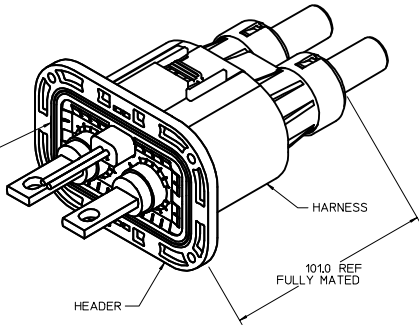

HEADER MATED TO HARNESS

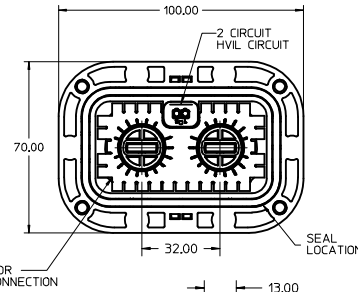
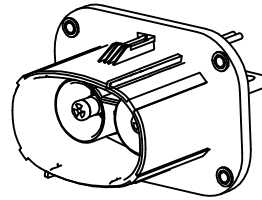

NOTES:

- MATERIAL:
MAIN HOUSING: POLYESTER 94V-0 (OPTIONAL UV STABILIZED)
COLOR: ORANGE
POWER TERMINALS: COPPER
HVIL TERMINALS: COPPER ALLOY
- FINISH:
POWER TERMINALS: SILVER OVER NICKEL PLATING
HVIL TERMINALS: TIN OVER NICKEL PLATING
- WIRE FOR HVIL TERMINALS: 18 GAGE TXL AUTOMOTIVE GRADE STRANDED WIRE
- MATES WITH HARNESS ASSEMBLY SERIES 171466-1***
- ATTACH HEADER WITH SCREWS TO PANEL PER MOLEX APPLICATION SPEC
- PRODUCT SPECIFICATION: PS-171467-001
- APPLICATION SPECIFICATION: AS-171467-001
- PACKAGING SPECIFICATION: PK-171467-999
- SHIELD MATING SURFACE WITHIN THE KEEP OUT ZONE MUST BE A CLEAN SURFACE WITH TIN OR NICKEL PLATING
- BUS BAR AND MOUNTING HARDWARE TO BE OVERALL TIN PLATED

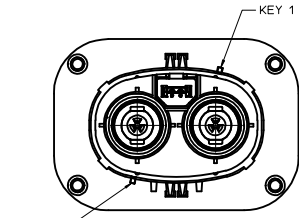

OPTION A
KEYING 1-4
MOLEX STANDARD
KEYIN VERSION

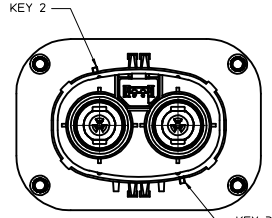

OPTION B
KEYING 2-3

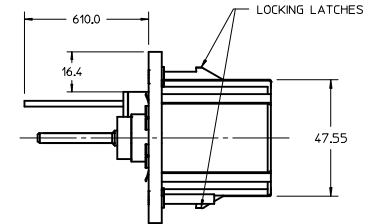
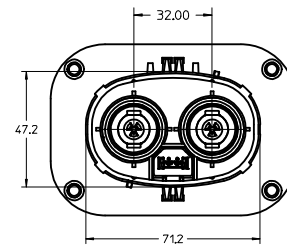
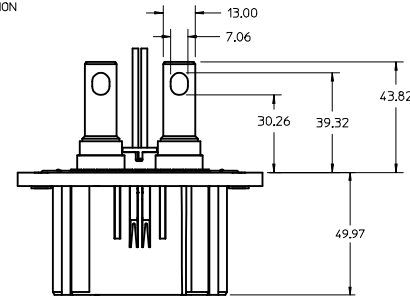

USE OF THIS PRODUCT REQUIRES THAT APPROPRIATE HIGH VOLTAGE WARNING LABELS BE APPLIED TO THE CABLE ASSEMBLY AND/OR IN CLOSE PROXIMITY OF THE MATED CONNECTOR APPLICATION IN A MANNER THAT PROVIDES SUITABLE WARNING TO THE END USER AND MEETS APPLICABLE LAWS. IT IS THE RESPONSIBILITY OF THE OEM OR MANUFACTURER OF THE PRODUCT IN WHICH THIS CONNECTOR SYSTEM IS USED TO APPLY THE APPROPRIATE HIGH VOLTAGE WARNING LABEL(S) TO THE FINAL PRODUCT. TO THE EXTENT MOLEX IS NOT RESPONSIBLE FOR THE FINAL CABLE ASSEMBLY, MOLEX DISCLAIMS ALL WARRANTIES AND LIABILITY THAT RESULT FROM A FAILURE TO PROVIDE AN APPROPRIATE WARNING.

REVISED PIN LOCATION EC NO: UCP2017-1062 DRAWN BY: MDATA CHKD: MDATA APPR: APATEL DESCRIPTION: 2016/10/02 DATE: 2016/10/21	QUALITY SYMBOLS	GENERAL TOLERANCES (UNLESS SPECIFIED)	DIMENSION STYLE	SCALE	DESIGN UNITS	THIRD ANGLE PROJECTION
	▽=0	mm INCH	MM ONLY	1:1	METRIC	☉
	▽=0	4 PLACES ± --- ± ---	DRAWN BY: MDATA	DATE: 2011/12/08	TITLE: HEADER ASSY PANEL MOUNT IMPERIUM	MOLEX INCORPORATED
	▽=0	3 PLACES ± --- ± ---	CHECKED BY: MDATA	DATE: 2011/12/21	DOCUMENT NO: SD-171467-1000	
	2 PLACES ± 0.60 ± ---	DRAFT WHERE APPLICABLE MUST REMAIN WITHIN DIMENSIONS	APPROVED BY: APATEL	DATE: 2012/04/11	THIS DRAWING CONTAINS INFORMATION THAT IS PROPRIETARY TO MOLEX INCORPORATED AND SHOULD NOT BE USED WITHOUT WRITTEN PERMISSION	

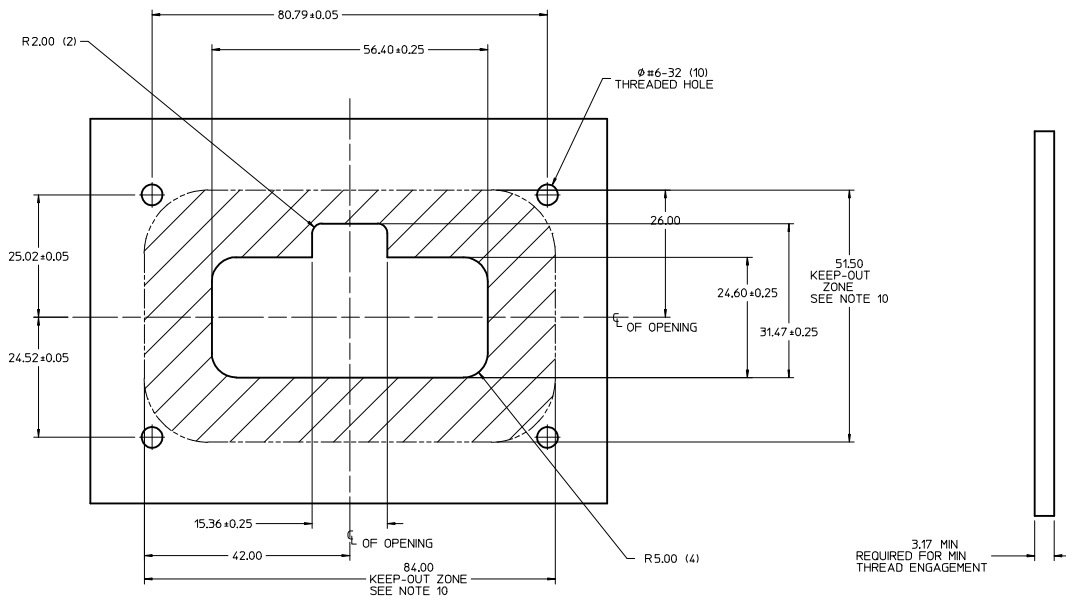

PANEL REQUIREMENTS
SCALE 2:1

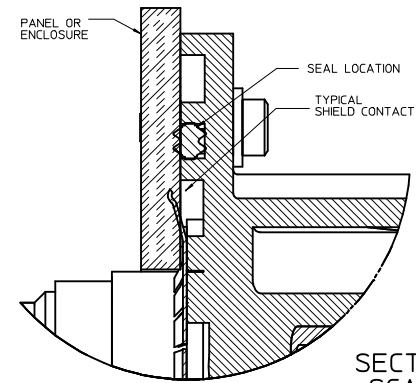
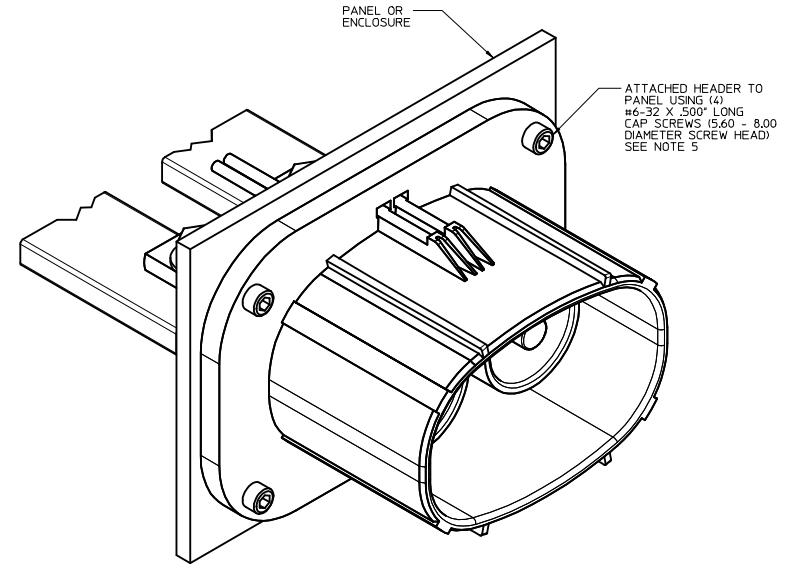

SECTION Z-Z
SCALE 4:1

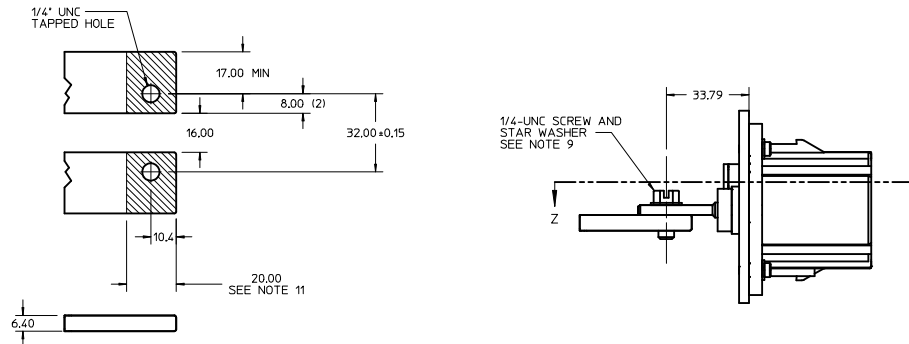

RECOMMENDED BUS BAR DETAIL

SEE SHEET 1 IEC NO: UCP2017-1062 DRAWN BY: CHYD APPR: APATEL DATE: 2016/12/21	QUALITY SYMBOLS	GENERAL TOLERANCES (UNLESS SPECIFIED)	DIMENSION STYLE	SCALE	DESIGN UNITS	THIRD ANGLE PROJECTION
	▽=0	mm INCH	MM ONLY	1:1	METRIC	☉
	▽=0	4 PLACES ± --- ± ---	DRAWN BY: MDATA	DATE: 2011/12/08	TITLE: HEADER ASSY PANEL MOUNT IMPERIUM	MOLEX INCORPORATED MATERIAL NO: SD-171467-1000 DOCUMENT NO: SD-171467-1000
	▽=0	3 PLACES ± --- ± --- 2 PLACES ± 0.60 ± --- 1 PLACE ± 0.90 ± --- ANGULAR ±1/2°	CHECKED BY: MDATA	DATE: 2011/12/21	SHEET NO: 2 OF 2	
DRAFT WHERE APPLICABLE MUST REMAIN WITHIN DIMENSIONS		SIZE D	THIS DRAWING CONTAINS INFORMATION THAT IS PROPRIETARY TO MOLEX INCORPORATED AND SHOULD NOT BE USED WITHOUT WRITTEN PERMISSION			