

Multi Chassis Tank (rescue platform) DG012-RV



Parts list:

1 Aluminum chassis top 1pc	2 Aluminum chassis bottom 1pc	3 Φ4 kimi screw 2pcs	4 DC motor 2pcs
5 Track wheel 8pcs	6 Rubber belt 4pcs	7 M3*6 hex screw 2pcs	8 M3*8 round head screw 8pcs
9 Φ3 hex Φ4 hex 1pc	10 spanner (M2.5 & M4) 1pc	11 spanner (M2 & M3) 1pc	12 Distance holder M3*25 4pcs

13 M3*8 flat-head screw 8pcs	14 M3*35 screw 2pcs	15 M3*16 screw with flange 2pcs	16 M3 nyloc nut 2pcs
17 M3 washer (thin) 10pcs	18 M2.5*25 screw 2pcs	19 M2.5 nyloc screw 4pcs	20 M3 nut 4pcs
21 M3*8 screw with flange 4pcs	22 Φ3*10 spacer 2pcs	23 M2.5*20 screw 2pcs	24 Φ3*28 spacer 2pcs
25 15*20*1 washer 4pcs	26 Hall sensor holder 2pcs	27 M2.3*8 tapping screw with flange 6pcs	28 10*15*4 flange bearings 4pcs
29 5XAA battery holder 1pc	30 Screw driver 1pc	31 Hall sensor encoder kit 2pcs	32 Φ4 Hexagonal connecting piece 2pcs

33 Delicate aluminum bracket 2pcs	34 Long axle 1pc	35 Φ4 16T synchronizing gear 1pc	36 Φ4 24T synchronizing gear 1pc
37 60MXL synchronizing belt 1pc	38 Hall sensor 2pcs	39 13kgs servo 1pc	40 M3*22 screw 1pc
41 U shape holder 1pc	42 Φ3*12 spacer 1pc		

Assembly Instructions:

Step 1:

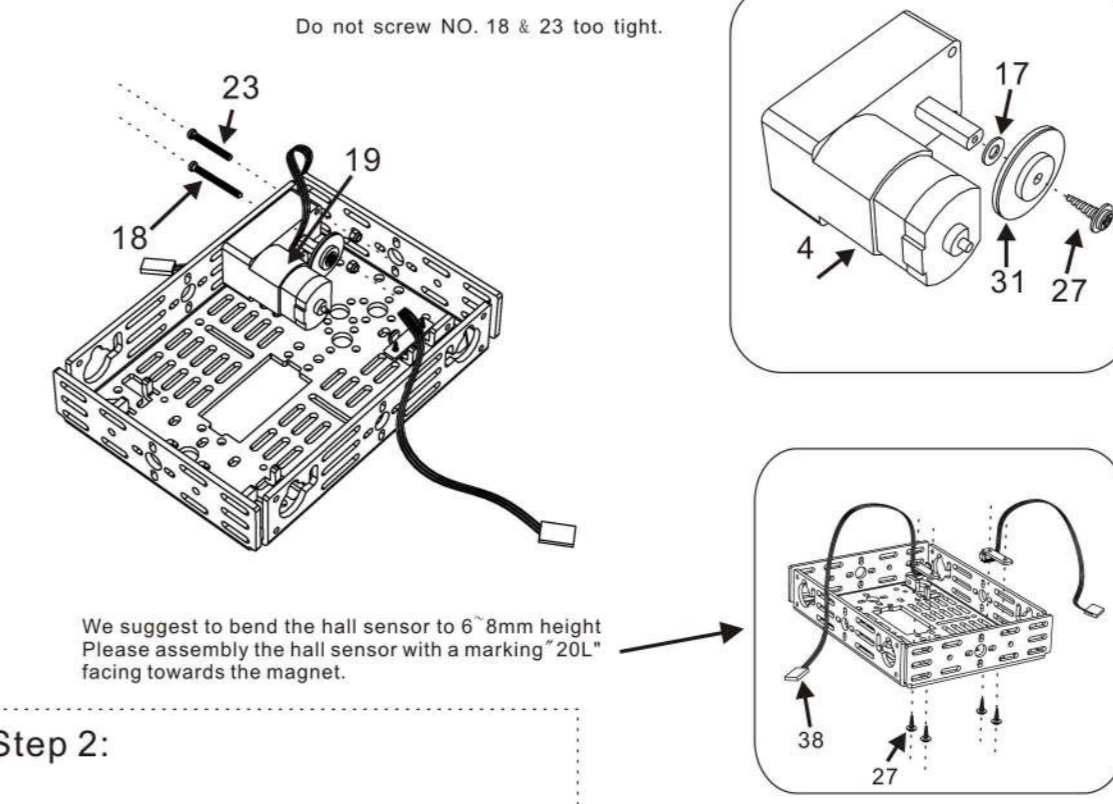

Step 2:

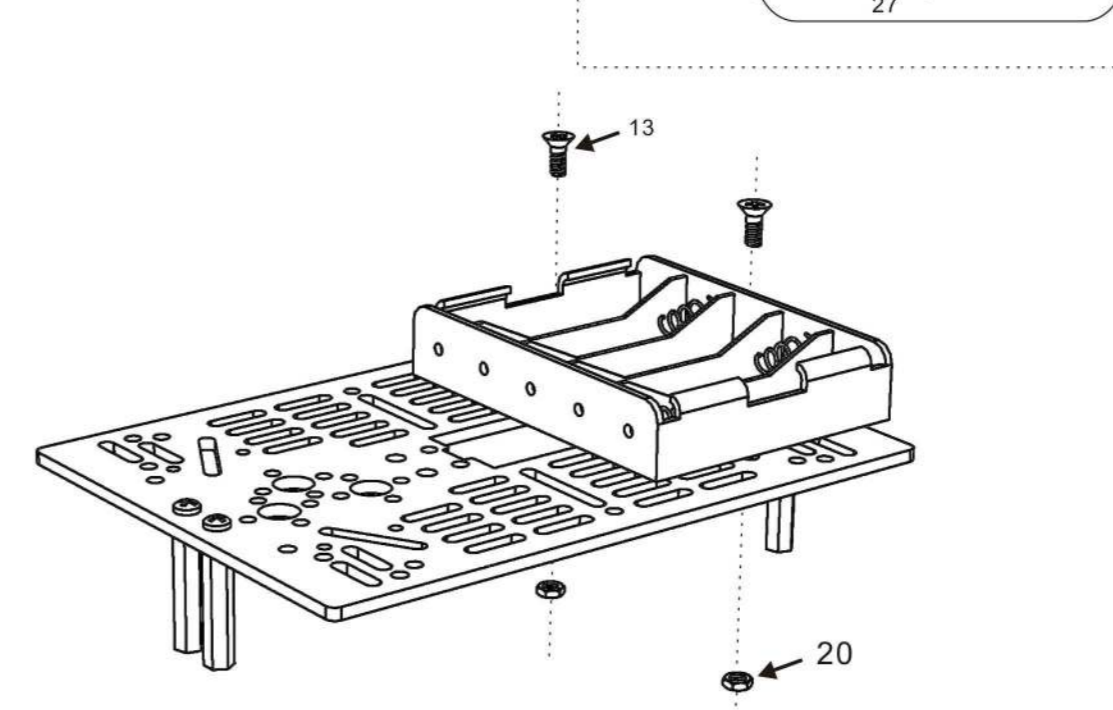

Step 3:

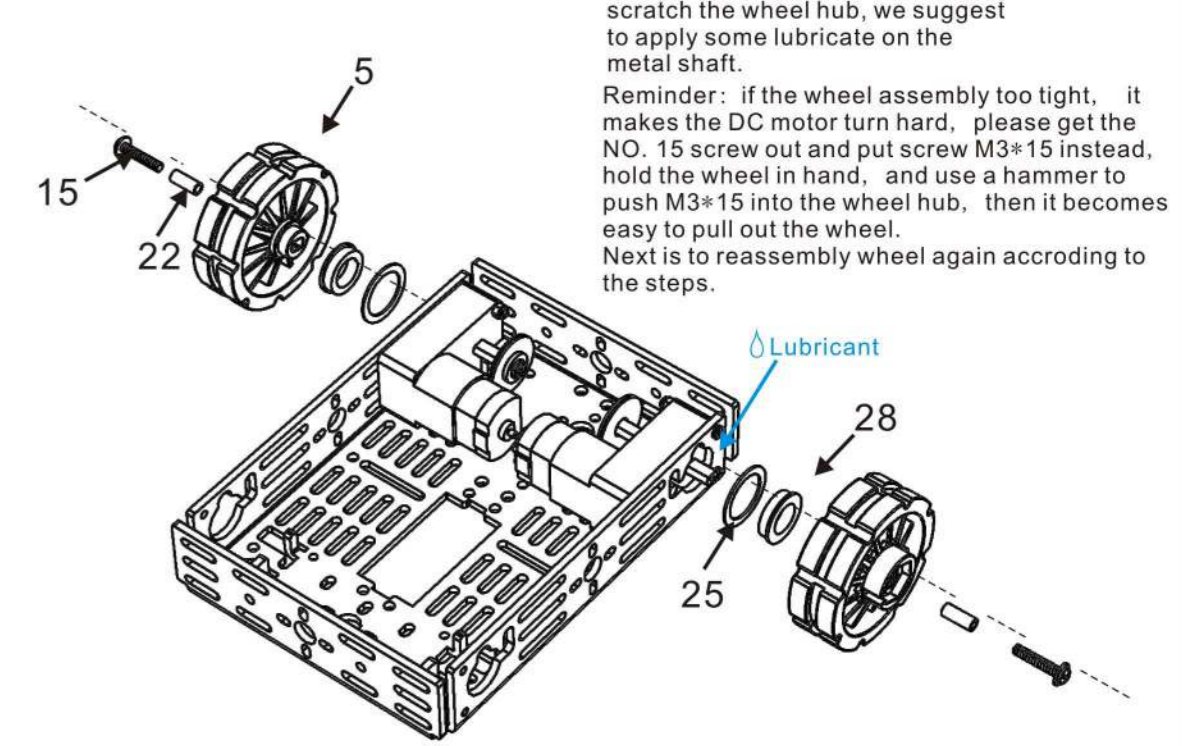

Step 4:

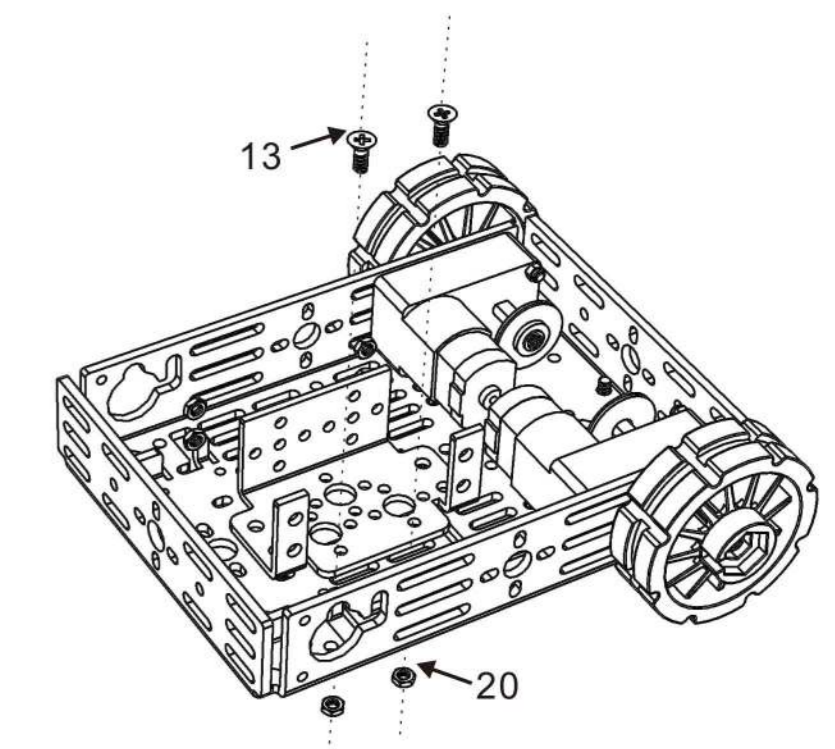

Step 5:

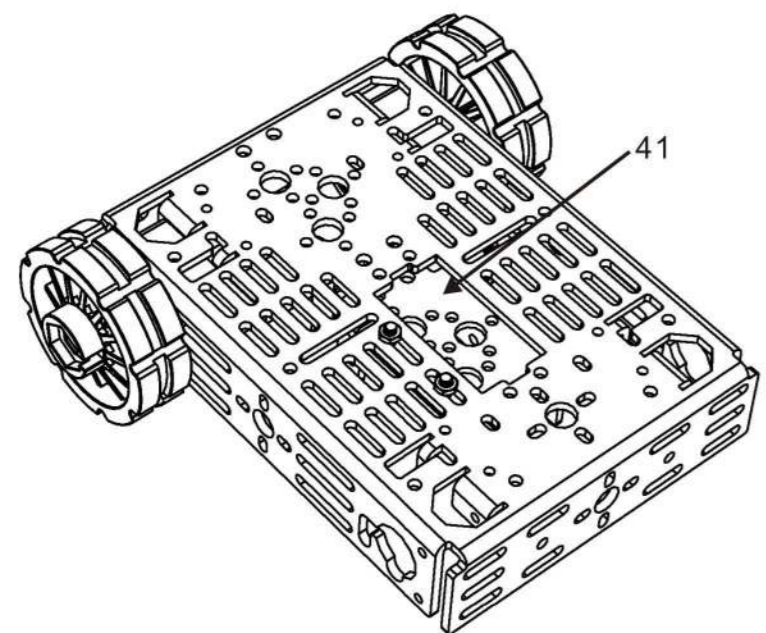

Step 6:

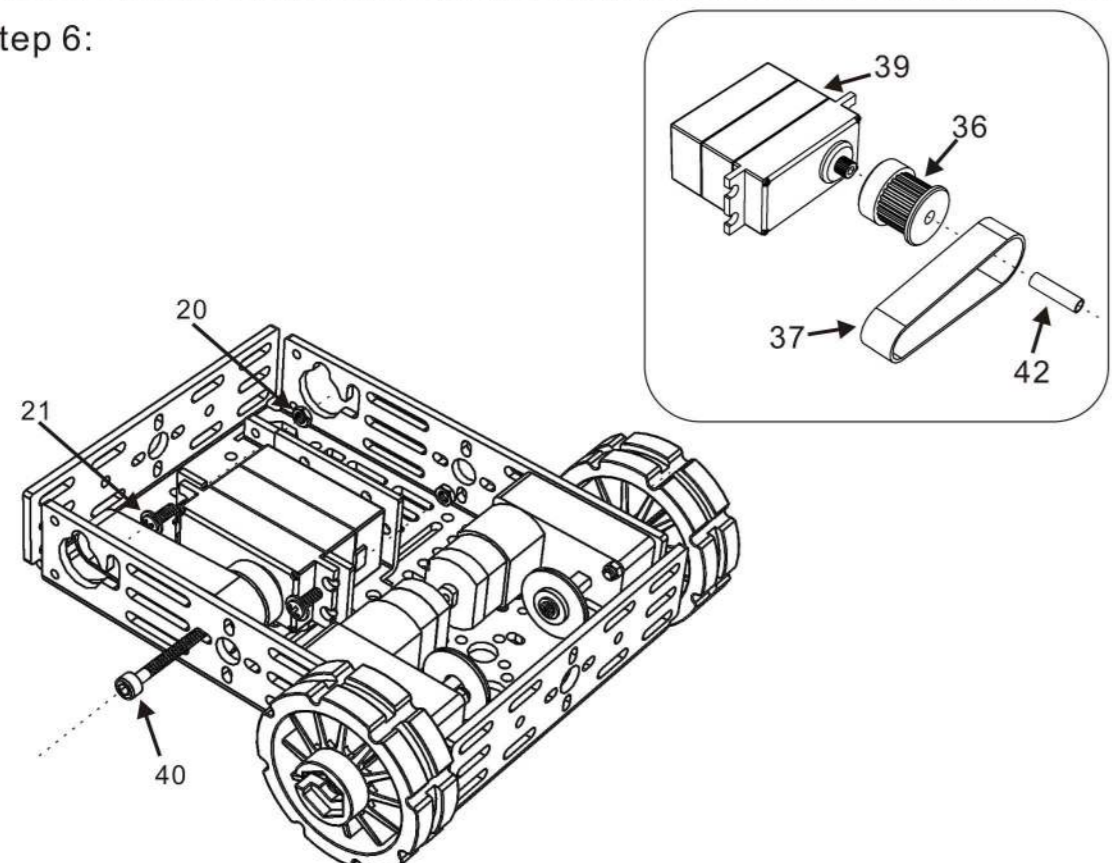

Step 7:

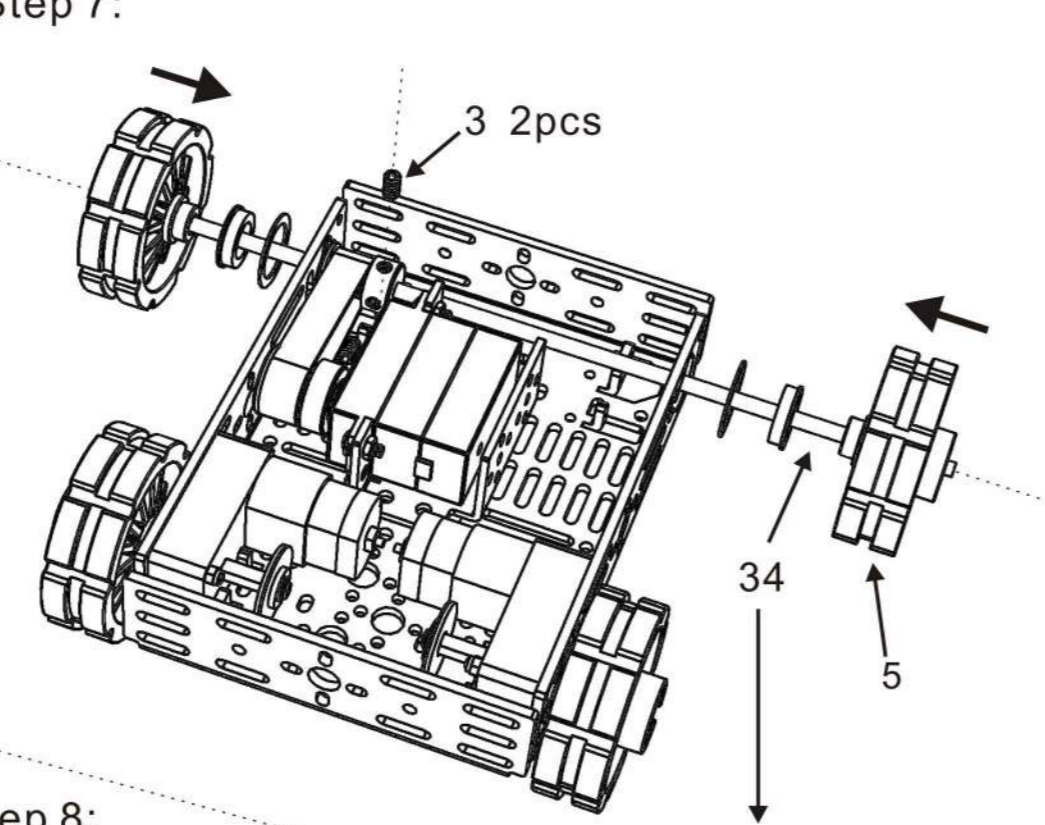

Step 8:

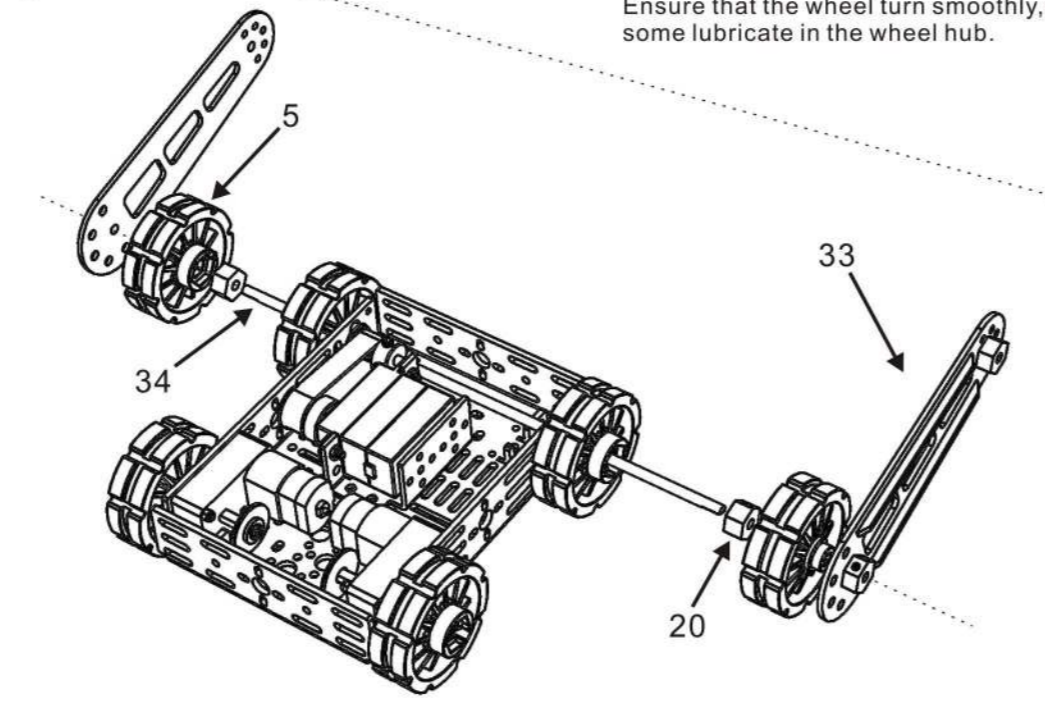

Step 9:

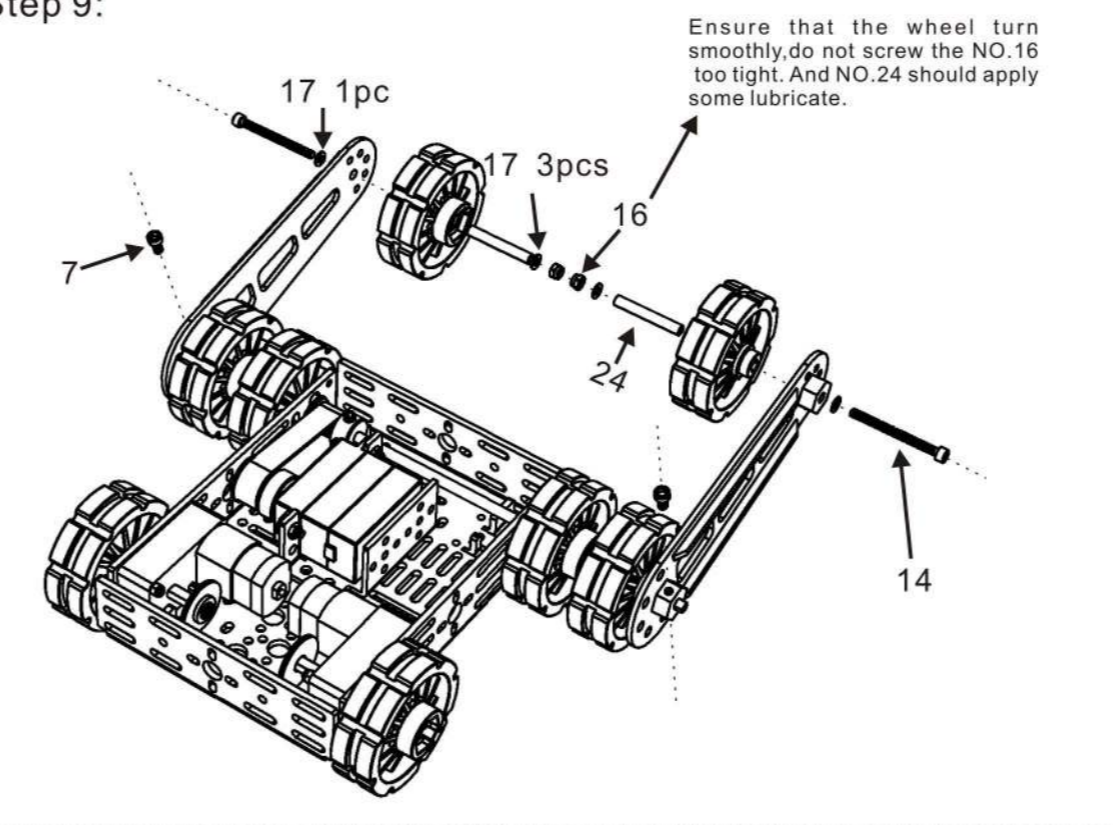

Step 10:

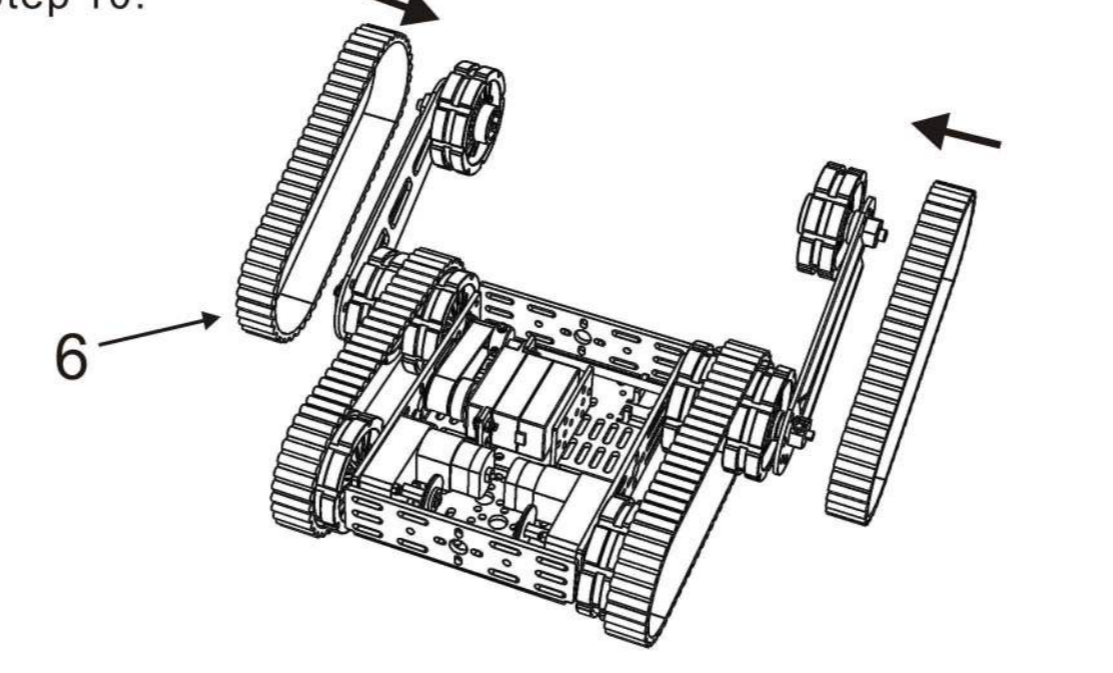

Step 11:

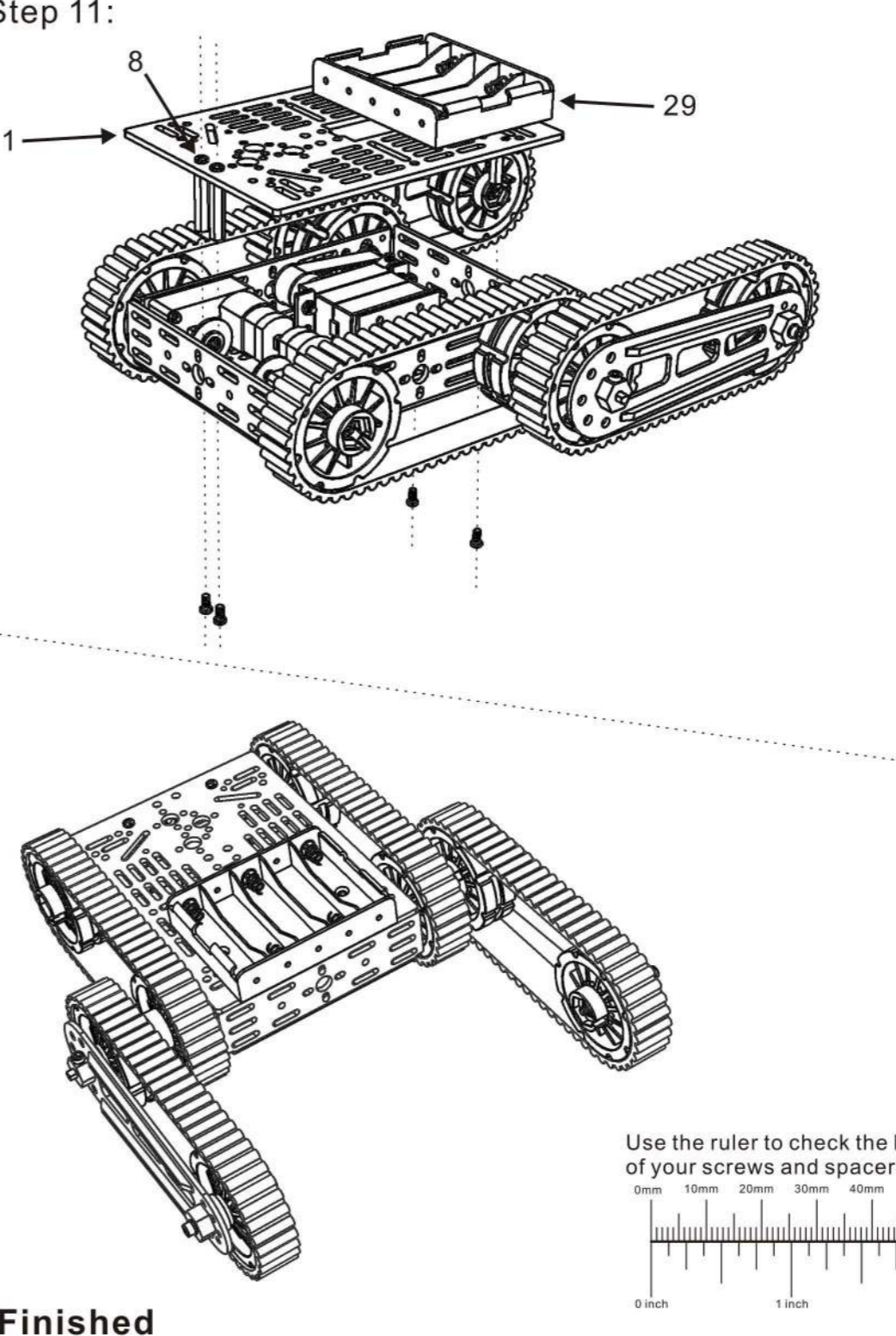

Finished