



American Electrical, Inc.

Industrial Electrical Accessories

425 Southlake Blvd. • Suite 9-B • Richmond, VA 23236 • (804) 379-2899 • Fax: (804) 379-8935

DIN Rail

- Steel design
- White zinc plating
- 2 meter length
- Standard packs of 20
- Competitive Pricing
- Industry standard Materials
- CE approved
- 6 types available
- No Markings on Rail

35 mm X 7.5 mm
Solid
Standard Pack: 20

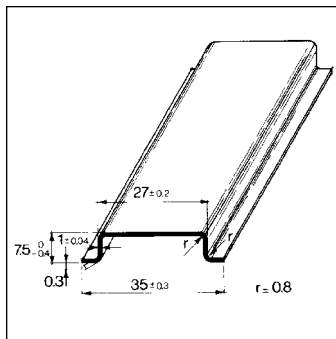

TS3575SOL



* Other Lengths Available

35 mm X 7.5 mm
Slotted
Standard Pack: 20

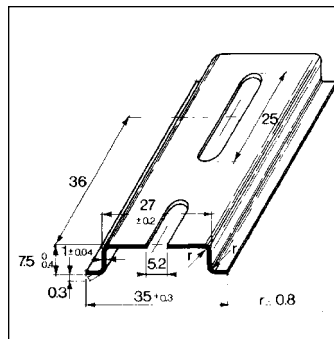

TS3575SL



* Other Lengths Available

32 mm X 15 mm
Solid
Standard Pack: 20

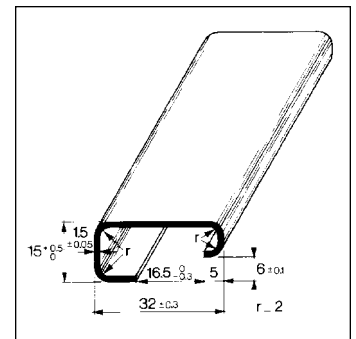

TS32SOL



DIN Rail

35 mm X 15 mm
Solid
Standard Pack: 20

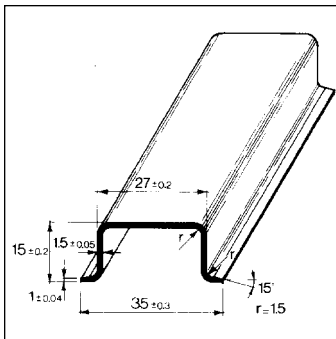

TS3515SOL



35 mm X 15 mm
Slotted
Standard Pack: 20

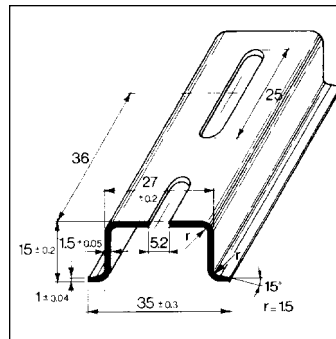

TS3515SL

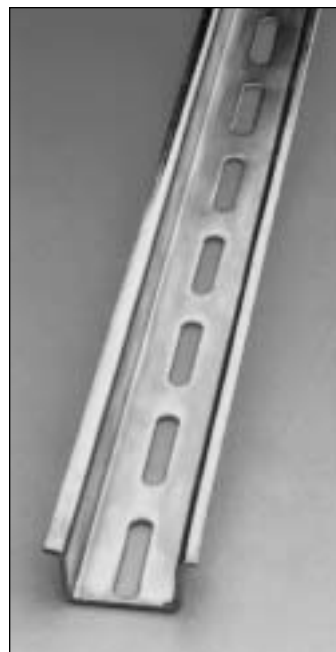

35 mm X 15 mm
Solid "Heavy"
Standard Pack: 20

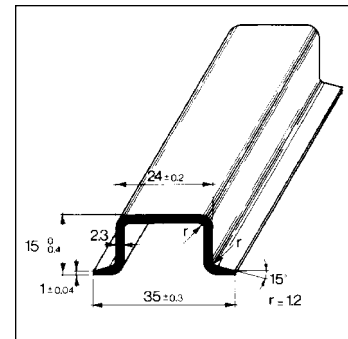

TS3515SOLH



DIN Rail Cross Reference List

American Electrical	TS3575SL*	TS3575SOL*	TS3515SL	TS3515SOL	TS32SOL	TS3515SOLH
Entr el ec	173220.05	174300.17	101598.26	168700.22	163050.04	168500.12
Phoenix Contact	801733	801681	1201730	1201714	1201015	—
Wago	210-112	210-113	210-197	210-114	—	210-118
Weidmuller	51450	38340	23650	23640	12280	49800
Wiel and	98.300.1000.0	98.300.0000.0	98.370.1000.0	98.370.0000.0	98.190.0000.0	—

Other rail types available upon request.

* Other Lengths Available