

THIS DRAWING IS UNPUBLISHED. RELEASED FOR PUBLICATION  
 © COPYRIGHT - By - ALL RIGHTS RESERVED.

LOC		DIST		REVISIONS			
P	LTR	DESCRIPTION		DATE	DWN	APVD	
		G1		REVISED PER ECO-11-005030	11MAR11	RK HMR	

1. USE INSTRUCTION SHEET 408-2187.
2. ACCOMODATES 0.79 [.031] TO 4.78 [.188] PANEL THICKNESS.

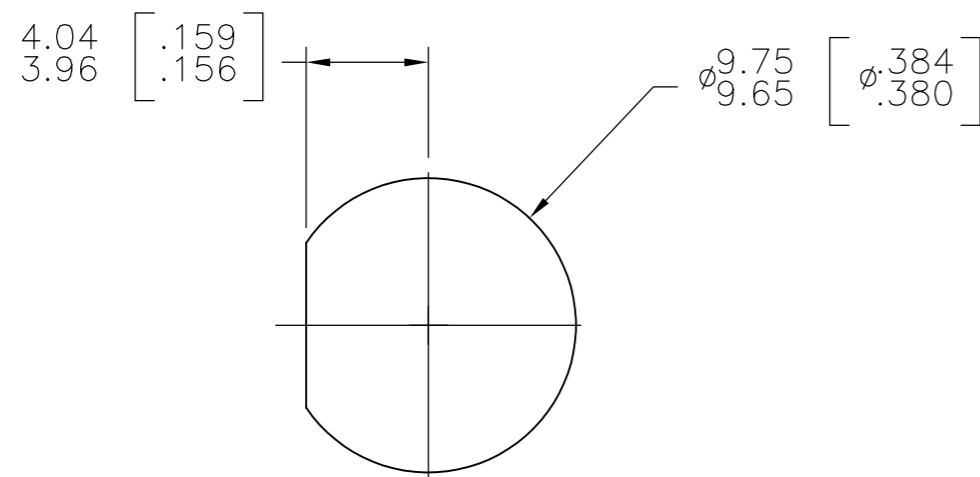
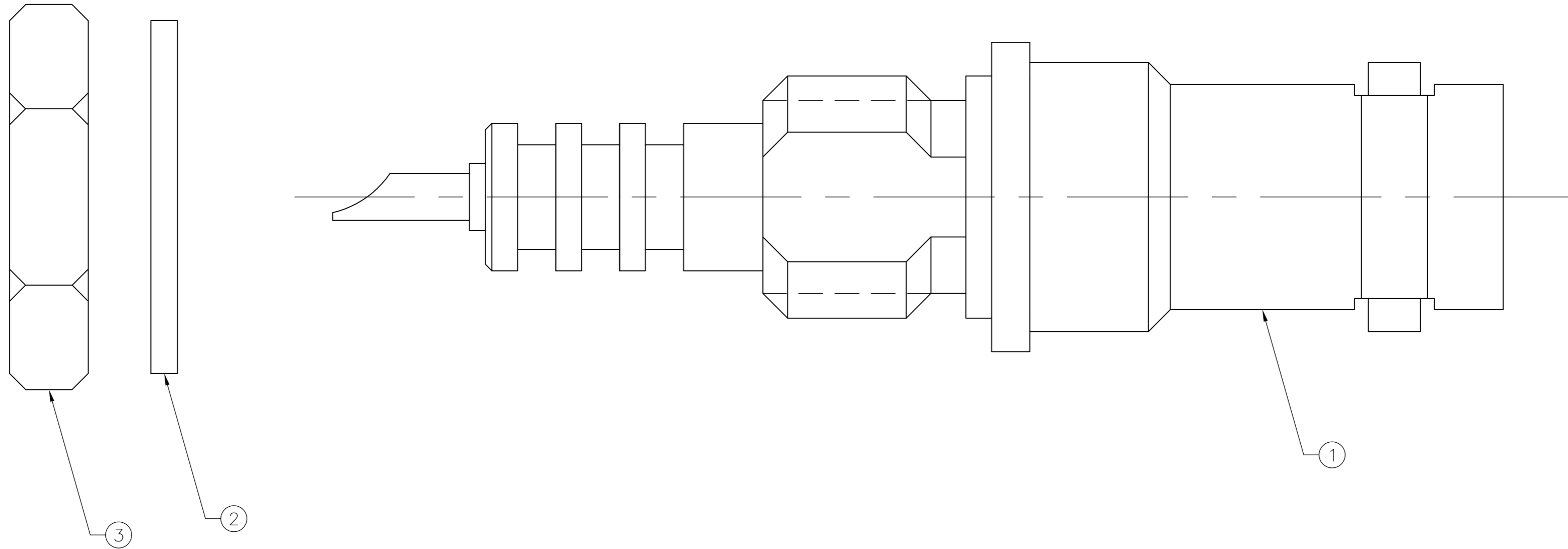

RECOMMENDED PANED CUTOUT  
SCALE 4:1

.461 oz	1-330249-1	1-329492-1	51531-2	51494-2
.423 oz	9-330249-0	9-329492-0	9-51531-0	51494-1
WEIGHT	③ JAM NUT QTY: 1	② LOCK WASHER QTY: 1	① JACK ASSEMBLY QTY: 1	PART NUMBER

THIS DRAWING IS A CONTROLLED DOCUMENT.		DWN	OBJAN08	TE Connectivity	
DIMENSIONS: mm [INCHES]		CHK	OBJAN08	NAME	
TOLERANCES UNLESS OTHERWISE SPECIFIED:		APVD	OBJAN08	SHV BULKHEAD SOLDER JACK	
0 PLC ± -		PRODUCT SPEC		SIZE	CAGE CODE
1 PLC ± -		APPLICATION SPEC		A2	00779
2 PLC ± 0.41[.016]				DRAWING NO	RESTRICTED TO
3 PLC ± -				C=51494	-
4 PLC ± -				SCALE	SHEET
ANGLES ± -		WEIGHT	-	1:1	1 of 1
FINISH				REV	G1
MATERIAL		CUSTOMER DRAWING			