

LOC		DIST		REVISIONS			
P	LTR	DESCRIPTION	DATE	DMN	APVD		
A		INITIAL RELEASE	18NOV2010	RC	CW		

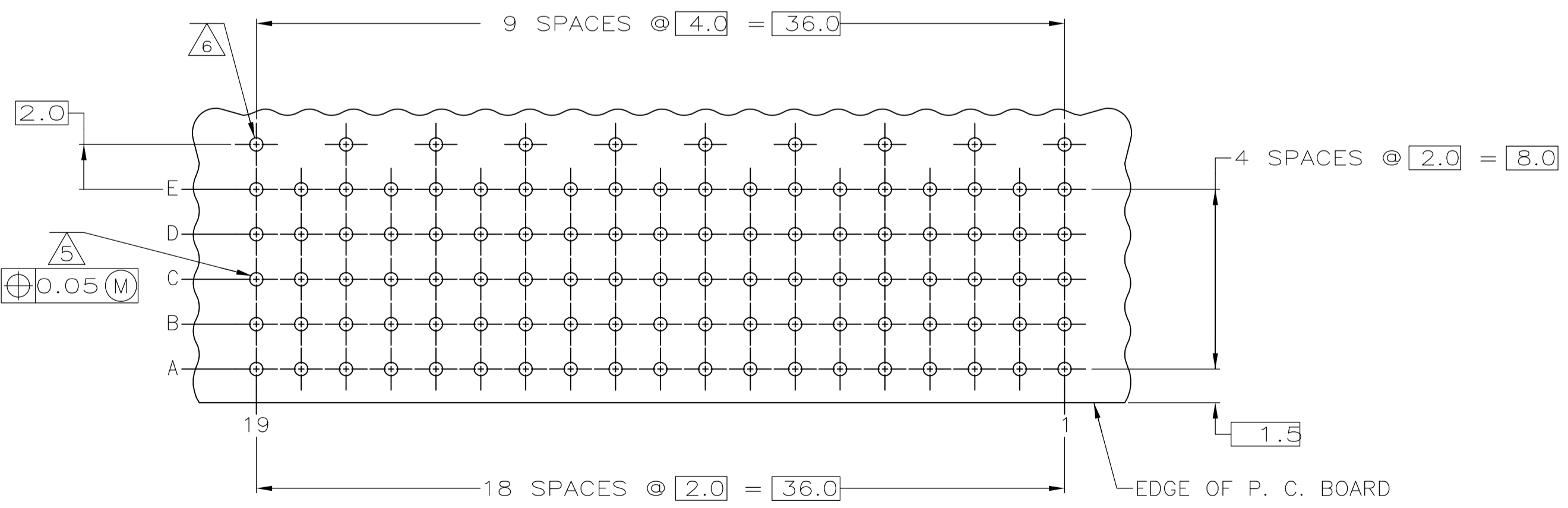
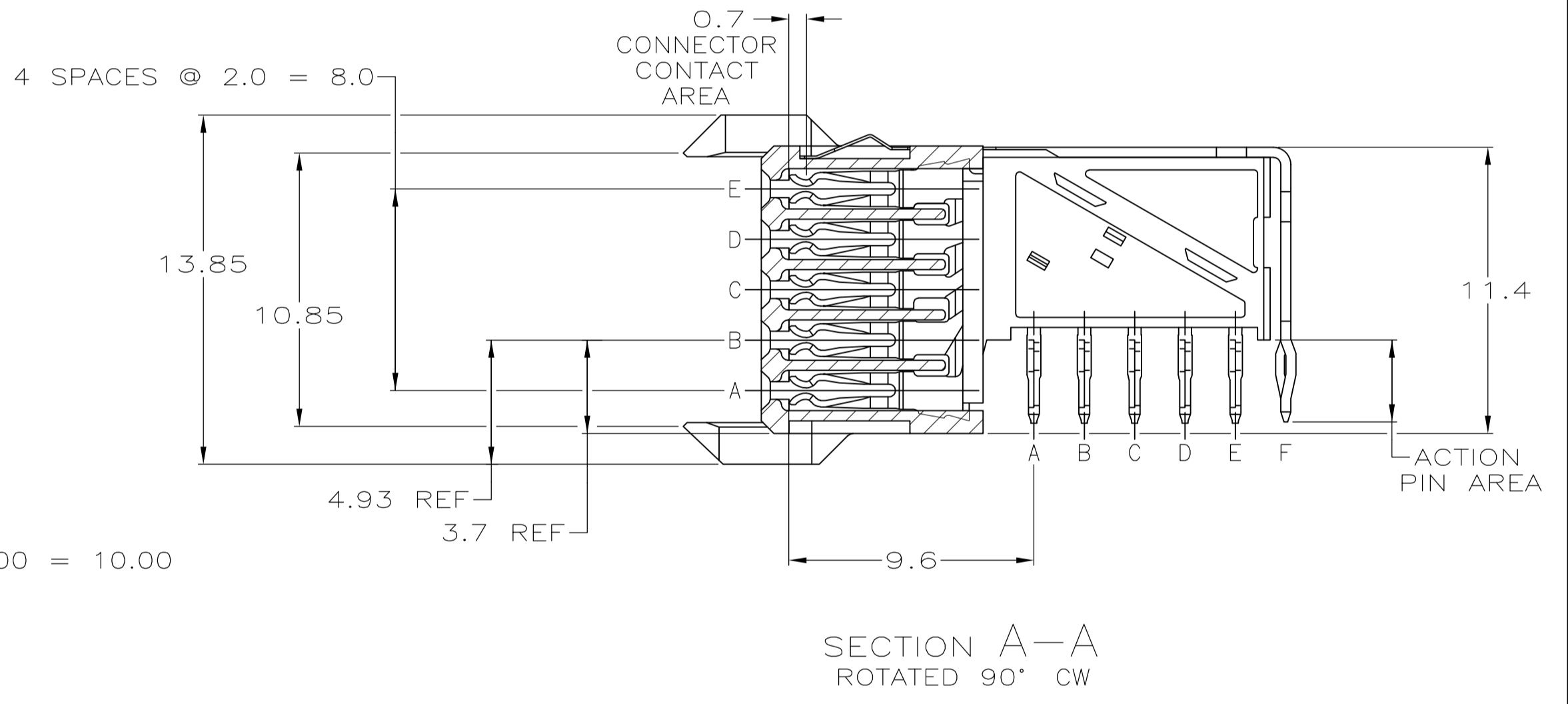
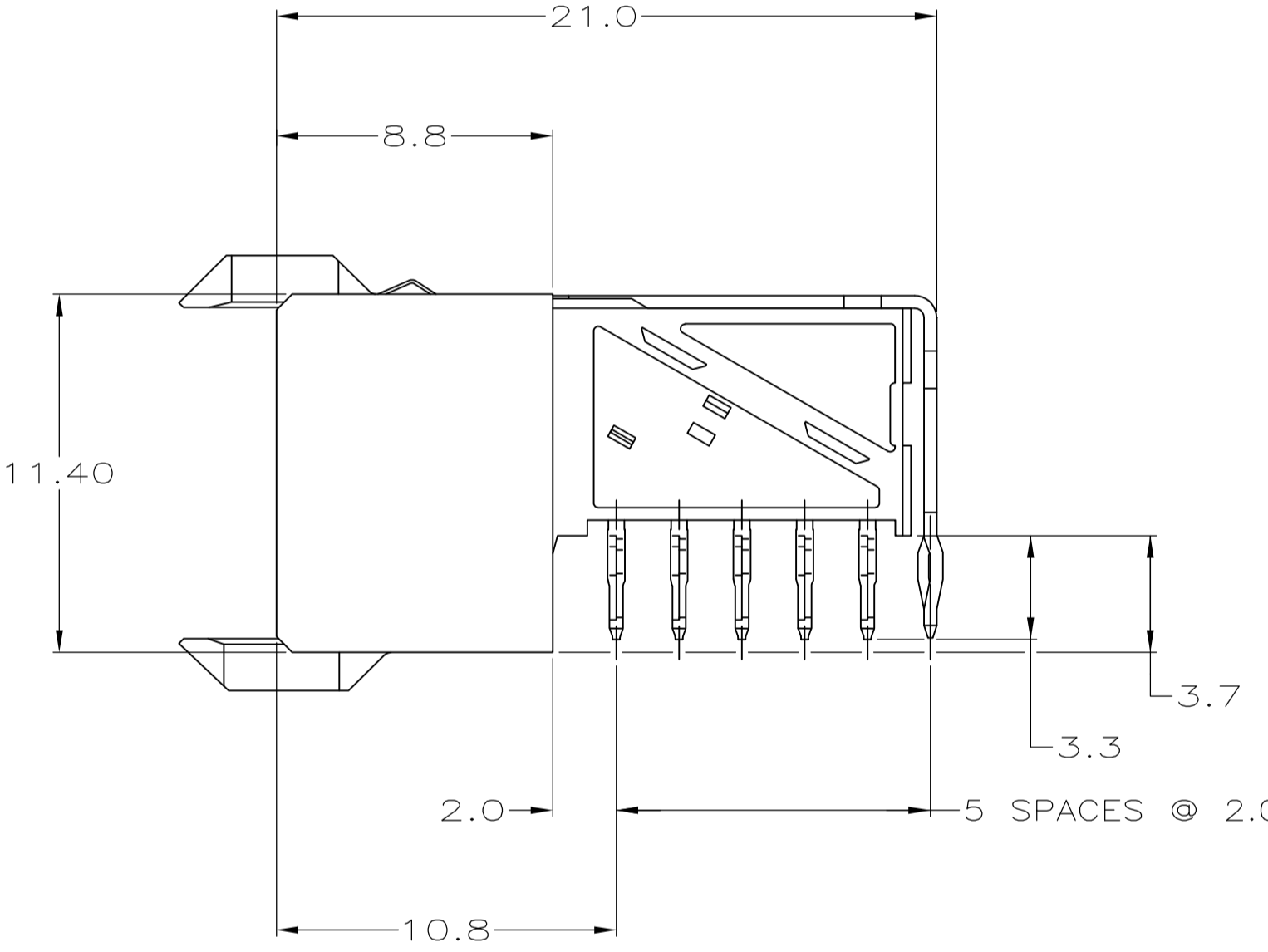
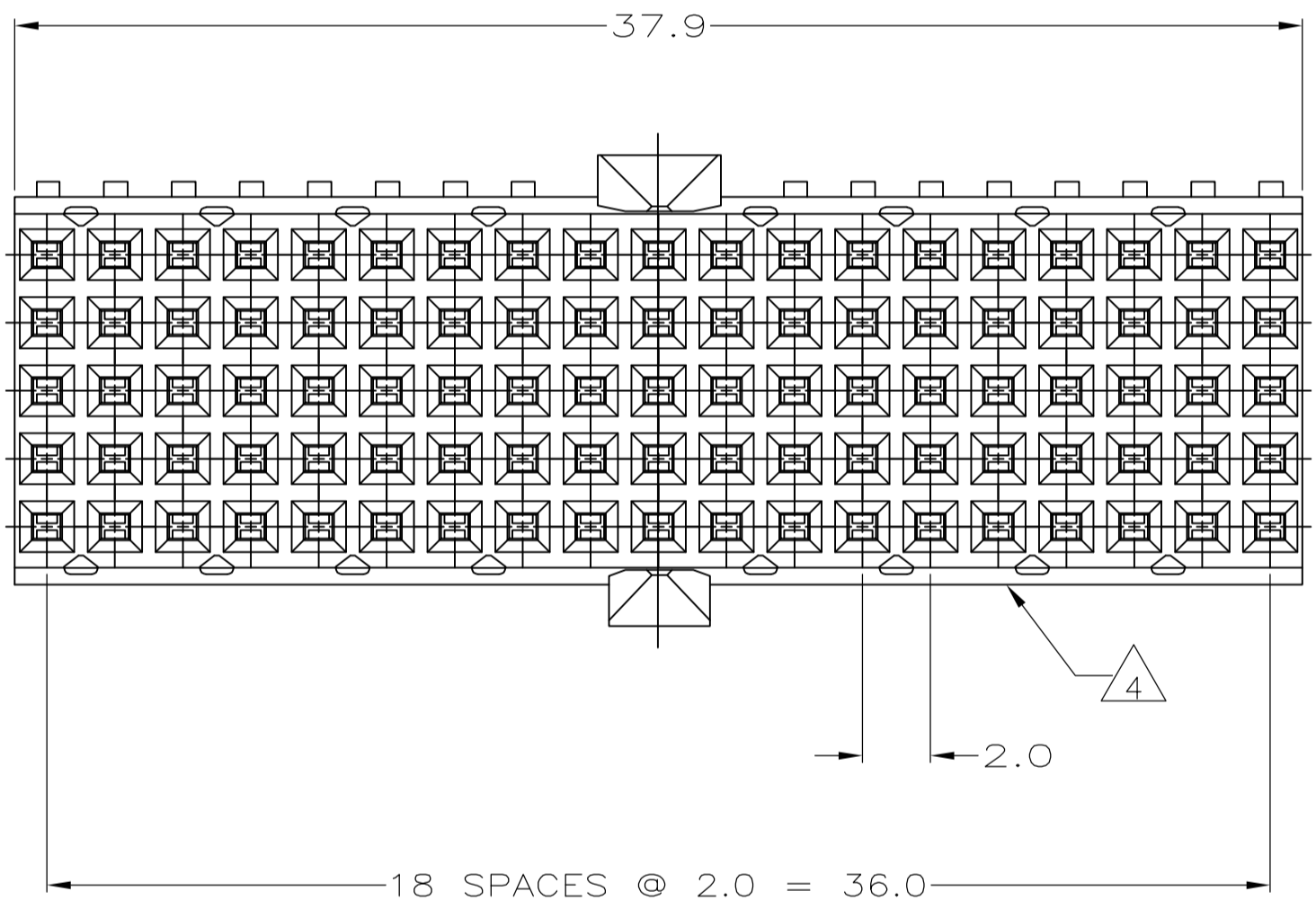
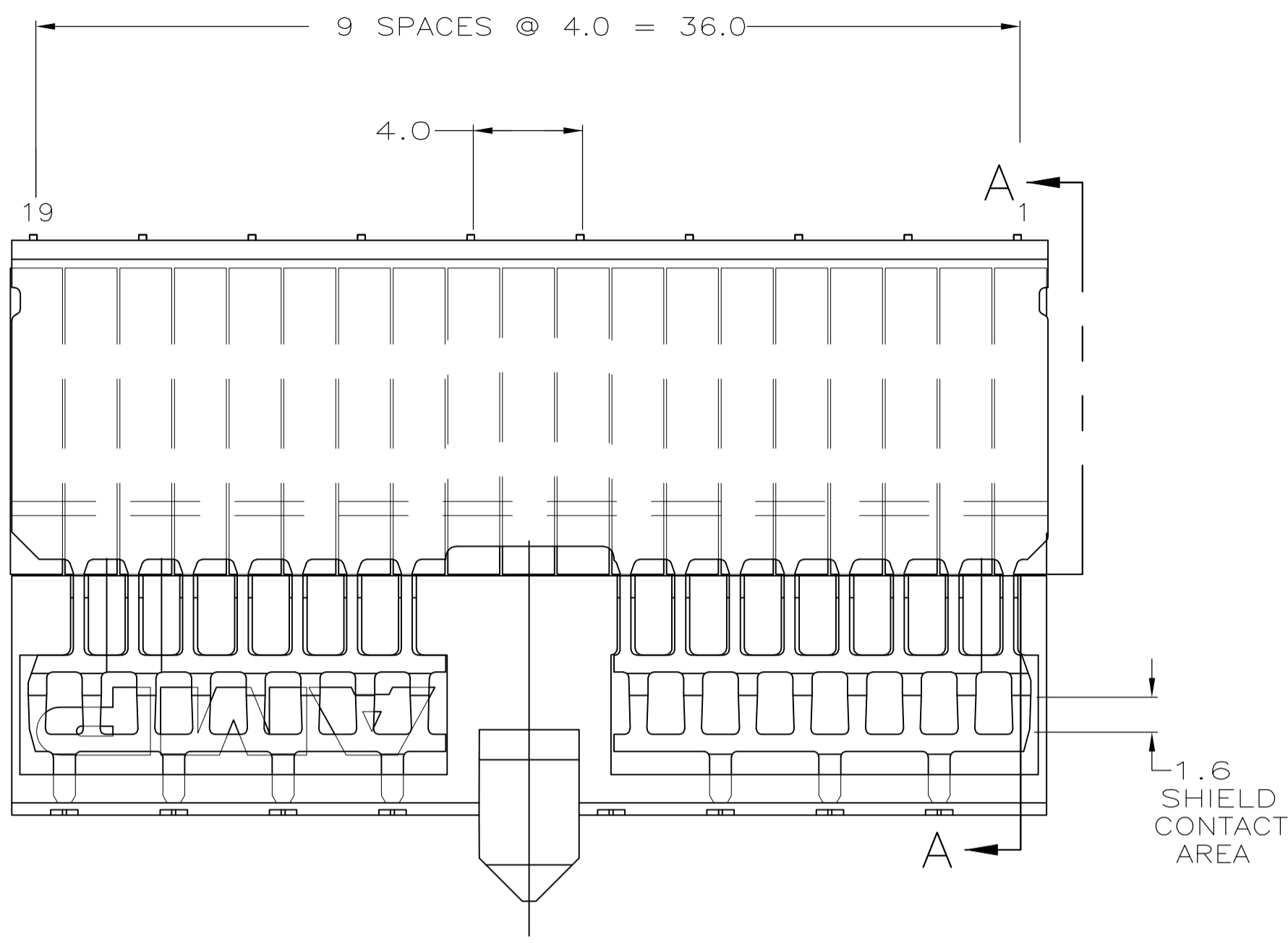

**RECOMMENDED PCB-HOLE LAYOUT  
 COMPONENT SIDE SHOWN**

SCALE 2.5:1

**PLATED THRU HOLES PARAMETERS**

REFERENCE APPLICATION SPECIFICATION

- 1 MATERIAL:  
CONTACT: PHOSPHOR BRONZE.  
HOUSING: GLASS-FILLED POLYESTER.
- 2 GENERAL PLATING SPECIFICATION: UNDERPLATING  
(ENTIRE CONTACT): 1.27μm MIN NICKEL AND ACTION  
PIN: 0.5μm MIN TIN/LEAD.  
1.27μm MIN GOLD PLATING AT MATING SURFACES
- 3 CONFORMS TO ALL TESTING ACCORDING TO IEC 61076-4-101  
PERFORMANCE LEVEL 1.
- 4 CONNECTOR MARKED WITH PART NUMBER AND DATE CODE.  
ADDITIONAL CHARACTERS OR MARKINGS, AS WELL AS THE LOCATION OF THE MARKINGS,  
MAY BE ADDED FOR TRACEABILITY BASED UPON MANUFACTURERS DISCRETION.
- 5 PLATED-THROUGH HOLES AT 2x2mm SQUARE GRID  
PATTERN DEFINED BY CONTACT LAYOUT.
- 6 10 PLATED THROUGH HOLES FOR UPPER SHIELD, ROW F.
- 7 SHIELD MOUNTED TO CONNECTOR WITH DOUBLE SIDED ADHESIVE TAPE OR ADHESIVE.

2 3	1645591-1
FINISH	PART NUMBER

THIS DRAWING IS A CONTROLLED DOCUMENT.		DIN RAYMOND CAO 11/18/2010		Tyco Electronics Corporation	
DIMENSIONS: mm		CHK SANDERS YAN 11/18/2010		Shanghai P.R.China	
TOLERANCES UNLESS OTHERWISE SPECIFIED:		APVD MANQIAN WANG 11/18/2010		NAME	
0-PLC ±		PRODUCT SPEC		RECEPTACLE ASSEMBLY, Z-PACK 2mm HM, TYPE A/B, PRE-SHIELDED, 95 POSITION	
1-PLC ±0.2		APPLICATION SPEC		SIZE	
2-PLC ±0.02		108-19082		CAGE CODE	
3-PLC ±0.2		114-19029		DRAWING NO	
4-PLC ±		WEIGHT		RESTRICTED TO	
ANGLES		A1 00779		1645591	
MATERIAL		CUSTOMER DRAWING		SCALE 5:1	
SEE TABLE		SHEET 1 OF 1		REV A	