

# SNx4AHC594 8-Bit Shift Registers With Output Registers

## 1 Features

- Operating Range 2-V to 5.5-V  $V_{CC}$
- 8-Bit Serial-In, Parallel-Out Shift Registers with Storage
- Independent Direct Overriding Clears on Shift and Storage Registers
- Independent Clocks for Shift and Storage Registers
- Latch-Up Performance Exceeds 100 mA Per JESD 78, Class II
- ESD Protection Exceeds JESD 22
  - 2000-V Human-Body Model (A114-A)
  - 200-V Machine Model (A115-A)
  - 1000-V Charged-Device Model (C101)

## 2 Applications

- Network Switches
- Power Infrastructures
- PCs and Notebooks
- LED Displays
- Servers

## 3 Description

The SNx4AHC594 devices contain an 8-bit serial-in, parallel-out shift register that feeds an 8-bit D-type storage register. Separate clocks and direct overriding clear (SRCLR, RCLR) inputs are provided on the shift and storage registers. A serial ( $Q_H$ ) output is provided for cascading purposes.

### Device Information<sup>(1)</sup>

PART NUMBER	PACKAGE	BODY SIZE (NOM)
SNx4AHC594	SOIC (16)	9.90 mm × 3.91 mm
	SSOP (16)	6.20 mm × 5.30 mm
	PDIP (16)	19.30 mm × 6.35 mm
	SOP (16)	12.60 mm × 5.30 mm
	TSSOP (16)	5.00 mm × 4.40 mm

(1) For all available packages, see the orderable addendum at the end of the data sheet.

### Simplified Schematic

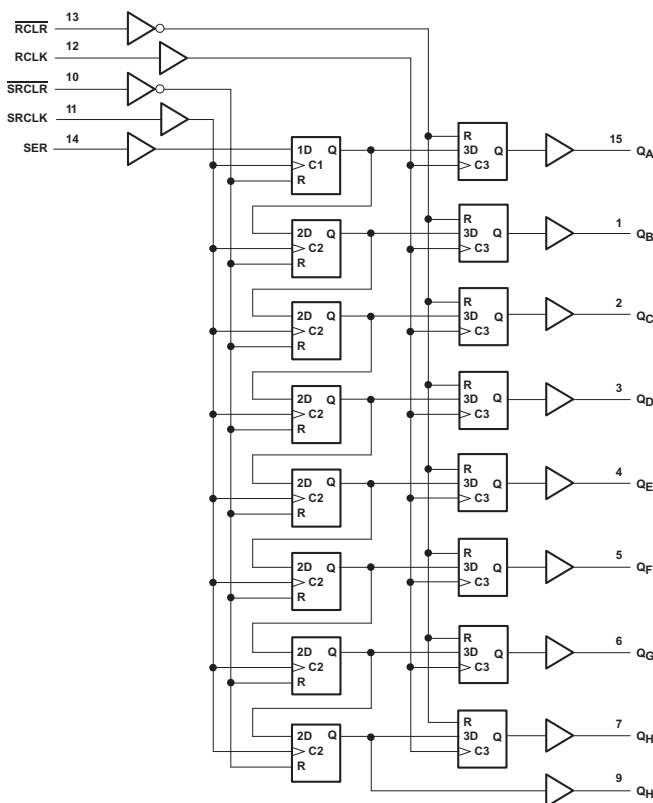

Pin numbers shown are for the D, DB, J, N, NS, PW, and W packages.



## Table of Contents

<b>1 Features</b> .....	<b>1</b>	<b>8 Detailed Description</b> .....	<b>11</b>
<b>2 Applications</b> .....	<b>1</b>	8.1 Overview .....	11
<b>3 Description</b> .....	<b>1</b>	8.2 Functional Block Diagram .....	11
<b>4 Revision History</b> .....	<b>2</b>	8.3 Feature Description .....	12
<b>5 Pin Configuration and Functions</b> .....	<b>3</b>	8.4 Device Functional Modes .....	12
<b>6 Specifications</b> .....	<b>4</b>	<b>9 Application and Implementation</b> .....	<b>13</b>
6.1 Absolute Maximum Ratings .....	4	9.1 Application Information .....	13
6.2 Handling Ratings .....	4	9.2 Typical Application .....	13
6.3 Recommended Operating Conditions .....	4	<b>10 Power Supply Recommendations</b> .....	<b>14</b>
6.4 Thermal Information .....	5	<b>11 Layout</b> .....	<b>14</b>
6.5 Electrical Characteristics .....	5	11.1 Layout Guidelines .....	14
6.6 Timing Requirements, $V_{CC} = 3.3\text{ V} \pm 0.3\text{ V}$ .....	6	11.2 Layout Example .....	14
6.7 Timing Requirements, $V_{CC} = 5\text{ V} \pm 0.5\text{ V}$ .....	6	<b>12 Device and Documentation Support</b> .....	<b>15</b>
6.8 Switching Characteristics, $V_{CC} = 3.3\text{ V} \pm 0.3\text{ V}$ .....	7	12.1 Related Links .....	15
6.9 Switching Characteristics, $V_{CC} = 5\text{ V} \pm 0.5\text{ V}$ .....	8	12.2 Trademarks .....	15
6.10 Noise Characteristics .....	8	12.3 Electrostatic Discharge Caution .....	15
6.11 Operating Characteristics .....	8	12.4 Glossary .....	15
6.12 Typical Characteristics .....	9	<b>13 Mechanical, Packaging, and Orderable Information</b> .....	<b>15</b>
<b>7 Parameter Measurement Information</b> .....	<b>10</b>		

## 4 Revision History

NOTE: Page numbers for previous revisions may differ from page numbers in the current version.

<b>Changes from Revision F (September 2003) to Revision G</b>	<b>Page</b>
• Updated document to new TI data sheet standards. ....	1
• Deleted Ordering Information table. ....	1
• Added Applications. ....	1
• Added Pin Functions table. ....	3
• Added Handling Ratings table. ....	4
• Changed MAX operating temperature from 85°C to 125°C in Recommended Operating Conditions table. ....	4
• Added Thermal Information table. ....	5
• Added Typical Characteristics section. ....	9
• Added Detailed Description section. ....	11
• Added Application and Implementation section. ....	13
• Added Power Supply Recommendations and Layout sections. ....	14

## 5 Pin Configuration and Functions

**SN54AHC594 . . . J OR W PACKAGE  
SN74AHC594 . . . D, DB, N, NS, OR PW PACKAGE  
(TOP VIEW)**

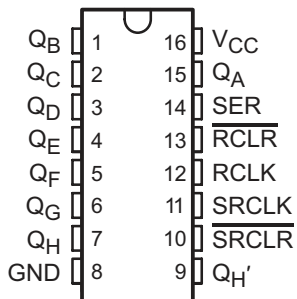

**SN54AHC594 . . . FK PACKAGE  
(TOP VIEW)**

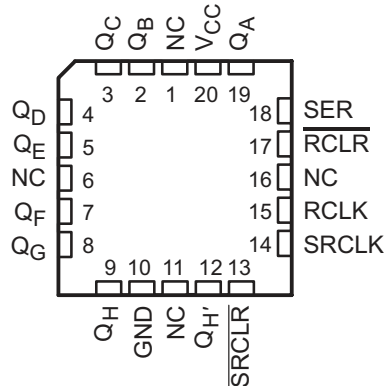

NC – No internal connection

### Pin Functions

Name	Pin		I/O	Description	
	SN54AHC594	SN74AHC594			
	FK	J, W	D, DB, N, NS, PW		
GND	10	8	8	—	Ground Pin
NC	1	—	—	—	No connect
	6				
	11				
	16				
QA	19	15	15	O	QA Output
QB	2	1	1	O	QB Output
QC	3	2	2	O	QC Output
QD	4	3	3	O	QD Output
QE	5	4	4	O	QE Output
QF	7	5	5	O	QF Output
QG	8	6	6	O	QG Output
QH	9	7	7	O	QH Output
QH'	12	9	9	O	QH' Output
RCLK	15	12	12	I	RCLK Input
RCLR	17	13	13	I	RCLR Input
SER	18	14	14	I	SER Input
SRCLK	14	11	11	I	SRCLK Input
SRCLR	13	10	10	I	SRCLR Input
VCC	20	16	16	—	Power pin

## 6 Specifications

### 6.1 Absolute Maximum Ratings

 over operating free-air temperature range (unless otherwise noted)<sup>(1)</sup>

		MIN	MAX	UNIT	
V <sub>CC</sub>	Supply voltage range	-0.5	7	V	
V <sub>I</sub>	Input voltage range <sup>(2)</sup>	-0.5	7	V	
V <sub>O</sub>	Output voltage range <sup>(2)</sup>	-0.5	V <sub>CC</sub> + 0.5	V	
I <sub>IK</sub>	Input clamp current	V <sub>I</sub> < 0		-20	mA
I <sub>OK</sub>	Output clamp current	V <sub>O</sub> < 0 or V <sub>O</sub> > V <sub>CC</sub>		±20	mA
I <sub>O</sub>	Continuous output current	V <sub>O</sub> = 0 to V <sub>CC</sub>		±25	mA
Continuous current through V <sub>CC</sub> or GND				±75	mA

- (1) Stresses beyond those listed under *Absolute Maximum Ratings* may cause permanent damage to the device. These are stress ratings only, which do not imply functional operation of the device at these or any other conditions beyond those indicated under *Recommended Operating Conditions*. Exposure to absolute-maximum-rated conditions for extended periods may affect device reliability.
- (2) The input and output voltage ratings may be exceeded if the input and output current ratings are observed.

### 6.2 Handling Ratings

		MIN	MAX	UNIT
T <sub>stg</sub>	Storage temperature range	-65	150	°C
V <sub>(ESD)</sub>	Electrostatic discharge	Human body model (HBM), per ANSI/ESDA/JEDEC JS-001, all pins <sup>(1)</sup>		V
		Charged device model (CDM), per JEDEC specification JESD22-C101, all pins <sup>(2)</sup>		
		0	2000	
		0	1000	

- (1) JEDEC document JEP155 states that 500-V HBM allows safe manufacturing with a standard ESD control process.
- (2) JEDEC document JEP157 states that 250-V CDM allows safe manufacturing with a standard ESD control process.

### 6.3 Recommended Operating Conditions

 over operating free-air temperature range (unless otherwise noted)<sup>(1)</sup>

		SN54AHC594 <sup>(2)</sup>		SN74AHC594		UNIT
		MIN	MAX	MIN	MAX	
V <sub>CC</sub>	Supply voltage	2	5.5	2	5.5	V
V <sub>IH</sub>	High-level input voltage	V <sub>CC</sub> = 2 V		1.5		V
		V <sub>CC</sub> = 3 V		2.1		
		V <sub>CC</sub> = 5.5 V		3.85		
V <sub>IL</sub>	Low-level input voltage	V <sub>CC</sub> = 2 V		0.5		V
		V <sub>CC</sub> = 3 V		0.9		
		V <sub>CC</sub> = 5.5 V		1.65		
V <sub>I</sub>	Input voltage	0	5.5	0	5.5	V
V <sub>O</sub>	Output voltage	0	V <sub>CC</sub>	0	V <sub>CC</sub>	V
I <sub>OH</sub>	High-level output current	V <sub>CC</sub> = 2 V		-50		μA
		V <sub>CC</sub> = 3 V ± 0.3 V		-4		mA
		V <sub>CC</sub> = 5.5 V ± 0.5 V		-8		mA
I <sub>OL</sub>	Low-level output current	V <sub>CC</sub> = 2 V		50		μA
		V <sub>CC</sub> = 3 V ± 0.3 V		4		mA
		V <sub>CC</sub> = 5.5 V ± 0.5 V		8		
Δt/Δv	Input transition rise and fall time	V <sub>CC</sub> = 3 V ± 0.3 V		100		ns/V
		V <sub>CC</sub> = 5.5 V ± 0.5 V		20		
T <sub>A</sub>	Operating free-air temperature	-55	125	-40	125	°C

- (1) All unused inputs of the device must be held at V<sub>CC</sub> or GND to ensure proper device operation. Refer to the TI application report, *Implications of Slow or Floating CMOS Inputs*, (SCBA004).
- (2) Product Preview

## 6.4 Thermal Information

THERMAL METRIC <sup>(1)</sup>		SN74AHC594					UNIT
		D	DB	N	NS	PW	
		16 PINS					
R <sub>θJA</sub>	Junction-to-ambient thermal resistance	80.2	97.5	47.5	79.1	105.7	°C/W
R <sub>θJC(top)</sub>	Junction-to-case (top) thermal resistance	39.1	47.7	34.9	35.4	40.4	
R <sub>θJB</sub>	Junction-to-board thermal resistance	27.7	48.1	27.5	39.9	50.7	
ψ <sub>JT</sub>	Junction-to-top characterization parameter	9.9	9.8	19.8	5.4	3.7	
ψ <sub>JB</sub>	Junction-to-board characterization parameter	37.4	47.6	27.4	39.5	50.1	
R <sub>θJC(bot)</sub>	Junction-to-case (bottom) thermal resistance	n/a	n/a	n/a	n/a	n/a	

(1) For more information about traditional and new thermal metrics, see the TI application report *IC Package Thermal Metrics (SPRA953)*.

## 6.5 Electrical Characteristics

over recommended operating free-air temperature range (unless otherwise noted)

PARAMETER	TEST CONDITIONS	V <sub>CC</sub>	T <sub>A</sub> = 25°C			SN54AHC594 <sup>(1)</sup>		SN74AHC594		UNIT
			MIN	TYP	MAX	MIN	MAX	MIN	MAX	
V <sub>OH</sub>	I <sub>OH</sub> = -50 μA	2 V	1.9	2		1.9		1.9	V	
		3 V	2.9	3		2.9		2.9		
		4.5 V	4.4	4.5		4.4		4.4		
	I <sub>OH</sub> = -4 mA	3 V	2.58			2.48		2.48		
		I <sub>OH</sub> = -8 mA	4.5 V	3.94			3.8			3.8
Q <sub>A</sub> - Q <sub>H</sub> I <sub>OH</sub> = -8 mA	3.94			3.8		3.8				
V <sub>OL</sub>	I <sub>OL</sub> = 50 μA	2 V			0.1		0.1	0.1	V	
		3 V			0.1		0.1	0.1		
		4.5 V			0.1		0.1	0.1		
	I <sub>OL</sub> = 4 mA	3 V			0.36		0.5	0.44		
		I <sub>OL</sub> = 8 mA	4.5 V			0.36		0.5		0.44
					0.36		0.5	0.44		
I <sub>I</sub>	V <sub>I</sub> = 5.5 V or GND	0 to 5.5 V			±0.1		±1 <sup>(2)</sup>	±1	μA	
I <sub>CC</sub>	V <sub>I</sub> = V <sub>CC</sub> or GND    I <sub>O</sub> = 0	5.5 V			4		40	40	μA	
C <sub>i</sub>	V <sub>I</sub> = V <sub>CC</sub> or GND	5 V		2	10			10	pF	

(1) Product Preview

(2) On products compliant to MIL-PRF-38535, this parameter is not production tested at V<sub>CC</sub> = 0 V.

## 6.6 Timing Requirements, $V_{CC} = 3.3\text{ V} \pm 0.3\text{ V}$

 over recommended operating free-air temperature range (unless otherwise noted) (see [Figure 4](#))

		$T_A = 25^\circ\text{C}$		SN54AHC594 <sup>(1)</sup>		SN74AHC594		UNIT
		MIN	MAX	MIN	MAX	MIN	MAX	
$t_w$	Pulse Duration	$\overline{\text{RCLK}}$ or SRCLK high or low	5.5		5.5		5.5	ns
		$\overline{\text{RCLR}}$ or $\overline{\text{SRCLR}}$ low	5		5		5	
$t_{su}$	Setup time	SER before SRCLK $\uparrow$	3.5		3.5		3.5	ns
		SRCLK $\uparrow$ before RCLK $\uparrow$ <sup>(2)</sup>	8		8.5		8.5	
		$\overline{\text{SRCLR}}$ low before SRCLK $\uparrow$	8		9		9	
		$\overline{\text{SRCLR}}$ high (inactive) before SRCLK $\uparrow$	4.2		4.8		4.8	
		$\overline{\text{RCLR}}$ high (inactive) before RCLK $\uparrow$	4.6		5.3		5.3	
$t_h$	Hold time, data after CLK $\uparrow$	SER after SRCLK $\uparrow$	1.5		1.5		1.5	ns

(1) Product Preview

(2) This setup time allows the storage register to receive stable data from the shift register. The clocks can be tied together, in which case the shift register is one clock pulse ahead of the storage register.

## 6.7 Timing Requirements, $V_{CC} = 5\text{ V} \pm 0.5\text{ V}$

 over recommended operating free-air temperature range (unless otherwise noted) (see [Figure 4](#))

		$T_A = 25^\circ\text{C}$		SN54AHC594 <sup>(1)</sup>		SN74AHC594		UNIT
		MIN	MAX	MIN	MAX	MIN	MAX	
$t_w$	Pulse Duration	$\overline{\text{RCLK}}$ or SRCLK high or low	5		5		5	ns
		$\overline{\text{RCLR}}$ or $\overline{\text{SRCLR}}$ low	5.2		5.2		5.2	
$t_{su}$	Setup time	SER before SRCLK $\uparrow$	3		3		3	ns
		SRCLK $\uparrow$ before RCLK $\uparrow$ <sup>(2)</sup>	5		5		5	
		$\overline{\text{SRCLR}}$ low before SRCLK $\uparrow$	5		5		5	
		$\overline{\text{SRCLR}}$ high (inactive) before SRCLK $\uparrow$	2.9		3.3		3.3	
		$\overline{\text{RCLR}}$ high (inactive) before RCLK $\uparrow$	3.2		3.7		3.7	
$t_h$	Hold time, data after CLK $\uparrow$	SER after SRCLK $\uparrow$	2		2		2	ns

(1) Product Preview

(2) This setup time allows the storage register to receive stable data from the shift register. The clocks can be tied together, in which case the shift register is one clock pulse ahead of the storage register.

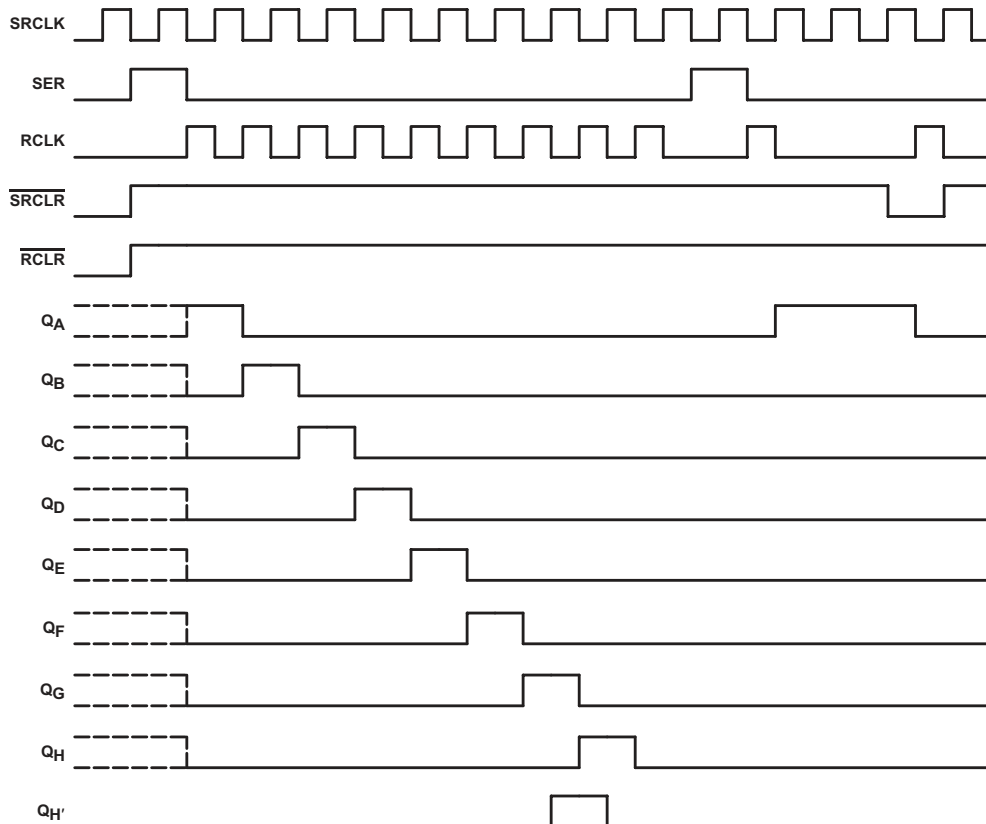
**Figure 1. Timing Diagram**

### 6.8 Switching Characteristics, $V_{CC} = 3.3\text{ V} \pm 0.3\text{ V}$

over recommended operating free-air temperature range (unless otherwise noted) (see [Figure 4](#))

PARAMETER	FROM (INPUT)	TO (OUTPUT)	LOAD CAPACITANCE	$T_A = 25^\circ\text{C}$			SN54AHC594 <sup>(1)</sup>		SN74AHC594		UNIT
				MIN	TYP	MAX	MIN	MAX	MIN	MAX	
$f_{\max}$			$C_L = 15\text{ pF}$	80 <sup>(2)</sup>	120 <sup>(1)</sup>		70 <sup>(2)</sup>		70		MHz
			$C_L = 50\text{ pF}$	55	105		50		50		
$t_{\text{PLH}}$	RCLK	$Q_A - Q_H$	$C_L = 15\text{ pF}$		4.6 <sup>(3)</sup>	8 <sup>(3)</sup>	1 <sup>(3)</sup>	8.5 <sup>(3)</sup>	1	8.5	ns
$t_{\text{PHL}}$					4.9 <sup>(3)</sup>	8.2 <sup>(3)</sup>	1 <sup>(3)</sup>	8.8 <sup>(3)</sup>	1	8.8	
$t_{\text{PLH}}$	SRCLK	$Q_{H'}$	$C_L = 15\text{ pF}$		5.4 <sup>(3)</sup>	9.1 <sup>(3)</sup>	1 <sup>(3)</sup>	9.7 <sup>(3)</sup>	1	9.7	ns
$t_{\text{PHL}}$					5.5 <sup>(3)</sup>	9.2 <sup>(3)</sup>	1 <sup>(3)</sup>	9.9 <sup>(3)</sup>	1	9.9	
$t_{\text{PHL}}$	$\overline{\text{RCLR}}$	$Q_A - Q_H$	$C_L = 15\text{ pF}$		6 <sup>(3)</sup>	9.8 <sup>(3)</sup>	1 <sup>(3)</sup>	10.6 <sup>(3)</sup>	1	10.6	ns
$t_{\text{PHL}}$	$\overline{\text{SRCLR}}$	$Q_{H'}$	$C_L = 15\text{ pF}$		5.6 <sup>(3)</sup>	9.2 <sup>(3)</sup>	1 <sup>(3)</sup>	10 <sup>(3)</sup>	1	10	ns
$t_{\text{PLH}}$	RCLK	$Q_A - Q_H$	$C_L = 50\text{ pF}$		6.9	10.5	1	11.1	1	11.1	ns
$t_{\text{PHL}}$					8.1	11.9	1	13.1	1	13.1	
$t_{\text{PLH}}$	SRCLK	$Q_{H'}$	$C_L = 50\text{ pF}$		7.7	11.7	1	12.4	1	12.4	ns
$t_{\text{PHL}}$					8.4	12.5	1	13.9	1	13.9	
$t_{\text{PHL}}$	$\overline{\text{RCLR}}$	$Q_A - Q_H$	$C_L = 50\text{ pF}$		9.1	13.1	1	14.4	1	14.4	ns
$t_{\text{PHL}}$	$\overline{\text{SRCLR}}$	$Q_{H'}$	$C_L = 50\text{ pF}$		8.5	12.4	1	14	1	14	ns

(1) Product Preview

(2) On products compliant to MIL-PRF-38535, this parameter is not production tested.

(3) On products compliant to MIL-PRF-38535, this parameter is not production tested.

## 6.9 Switching Characteristics, $V_{CC} = 5 V \pm 0.5 V$

 over recommended operating free-air temperature range (unless otherwise noted) (see [Figure 4](#))

PARAMETER	FROM (INPUT)	TO (OUTPUT)	LOAD CAPACITANCE	$T_A = 25^\circ\text{C}$			SN54AHC594 <sup>(1)</sup>		SN74AHC594		UNIT
				MIN	TYP	MAX	MIN	MAX	MIN	MAX	
$f_{\text{max}}$			$C_L = 15 \text{ pF}$	135 <sup>(2)</sup>	170 <sup>(2)</sup>		115 <sup>(2)</sup>		115		MHz
			$C_L = 50 \text{ pF}$	120	140		95		95		
$t_{\text{PLH}}$	RCLK	$Q_A - Q_H$	$C_L = 15 \text{ pF}$		3.3 <sup>(2)</sup>	6.2 <sup>(2)</sup>	1 <sup>(2)</sup>	6.5 <sup>(2)</sup>	1	6.5	ns
$t_{\text{PHL}}$					3.7 <sup>(2)</sup>	6.5 <sup>(2)</sup>	1 <sup>(2)</sup>	6.9 <sup>(2)</sup>	1	6.9	
$t_{\text{PLH}}$	SRCLK	$Q_{H'}$	$C_L = 15 \text{ pF}$		3.7 <sup>(2)</sup>	6.8 <sup>(2)</sup>	1 <sup>(1)</sup>	7.2 <sup>(2)</sup>	1	7.2	ns
$t_{\text{PHL}}$					4.1 <sup>(2)</sup>	7.2 <sup>(2)</sup>	1 <sup>(2)</sup>	7.6 <sup>(2)</sup>	1	7.6	
$t_{\text{PLH}}$	$\overline{\text{RCLR}}$	$Q_A - Q_H$	$C_L = 15 \text{ pF}$		4.5 <sup>(2)</sup>	7.6 <sup>(2)</sup>	1 <sup>(2)</sup>	8.2 <sup>(2)</sup>	1	8.2	ns
$t_{\text{PHL}}$				$\overline{\text{SRCLR}}$	$Q_{H'}$		4.1 <sup>(2)</sup>	7.1 <sup>(2)</sup>	1 <sup>(2)</sup>	7.6 <sup>(2)</sup>	
$t_{\text{PLH}}$	RCLK	$Q_A - Q_H$	$C_L = 50 \text{ pF}$		4.9	7.8	1	8.3	1	8.3	ns
$t_{\text{PHL}}$					5.8	8.9	1	9.7	1	9.7	
$t_{\text{PLH}}$	SRCLK	$Q_{H'}$	$C_L = 50 \text{ pF}$		5.5	8.6	1	9.1	1	9.1	ns
$t_{\text{PHL}}$					6	9.2	1	10.1	1	10.1	
$t_{\text{PLH}}$	$\overline{\text{RCLR}}$	$Q_A - Q_H$	$C_L = 50 \text{ pF}$		6.6	10	1	10.7	1	10.7	ns
$t_{\text{PHL}}$				$\overline{\text{SRCLR}}$	$Q_{H'}$		6	9.2	1	10.1	

(1) Product Preview

(2) On products compliant to MIL-PRF-38535, this parameter is not production tested.

## 6.10 Noise Characteristics

 $V_{CC} = 5 \text{ V}$ ,  $C_L = 50 \text{ pF}$ ,  $T_A = 25^\circ\text{C}$ <sup>(1)</sup>

PARAMETER		SN74AHC594			UNIT
		MIN	TYP	MAX	
$V_{OL(P)}$	Quiet output, maximum dynamic $V_{OL}$		1		V
$V_{OL(V)}$	Quiet output, minimum dynamic $V_{OL}$		-0.6		V
$V_{OH(V)}$	Quiet output, minimum dynamic $V_{OH}$		3.8		V
$V_{IH(D)}$	High-level dynamic input voltage	3.5			V
$V_{IL(D)}$	Low-level dynamic input voltage			1.5	V

(1) Characteristics are for surface-mount packages only.

## 6.11 Operating Characteristics

 $V_{CC} = 5 \text{ V}$ ,  $T_A = 25^\circ\text{C}$ 

PARAMETER		TEST CONDITIONS	TYP	UNIT
$C_{\text{pd}}$	Power dissipation capacitance	No load, $f = 1 \text{ MHz}$	112	pF



## 6.12 Typical Characteristics

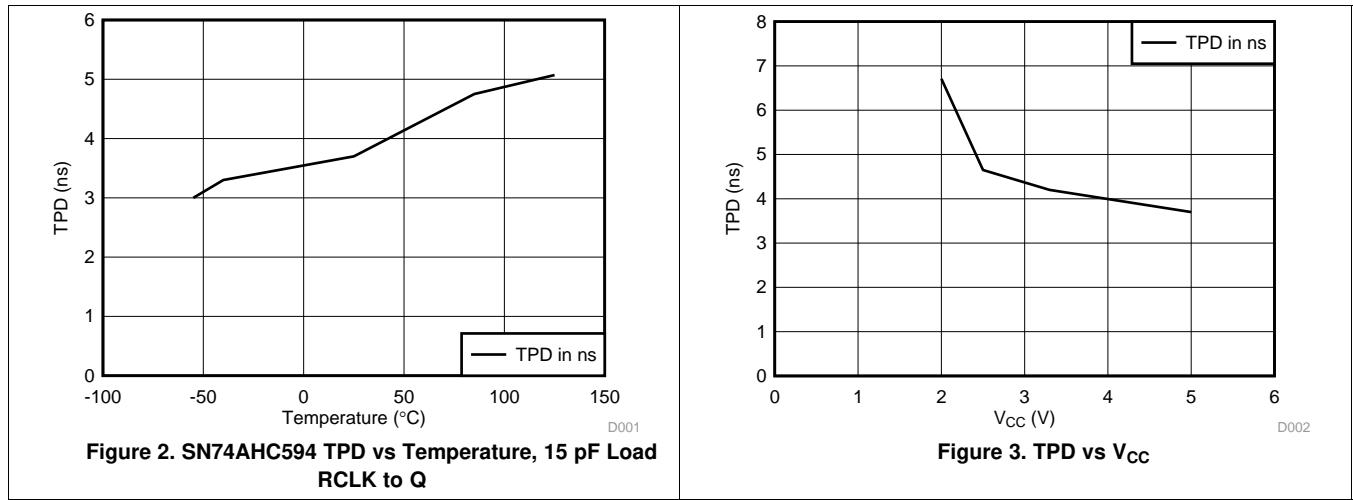

## 7 Parameter Measurement Information

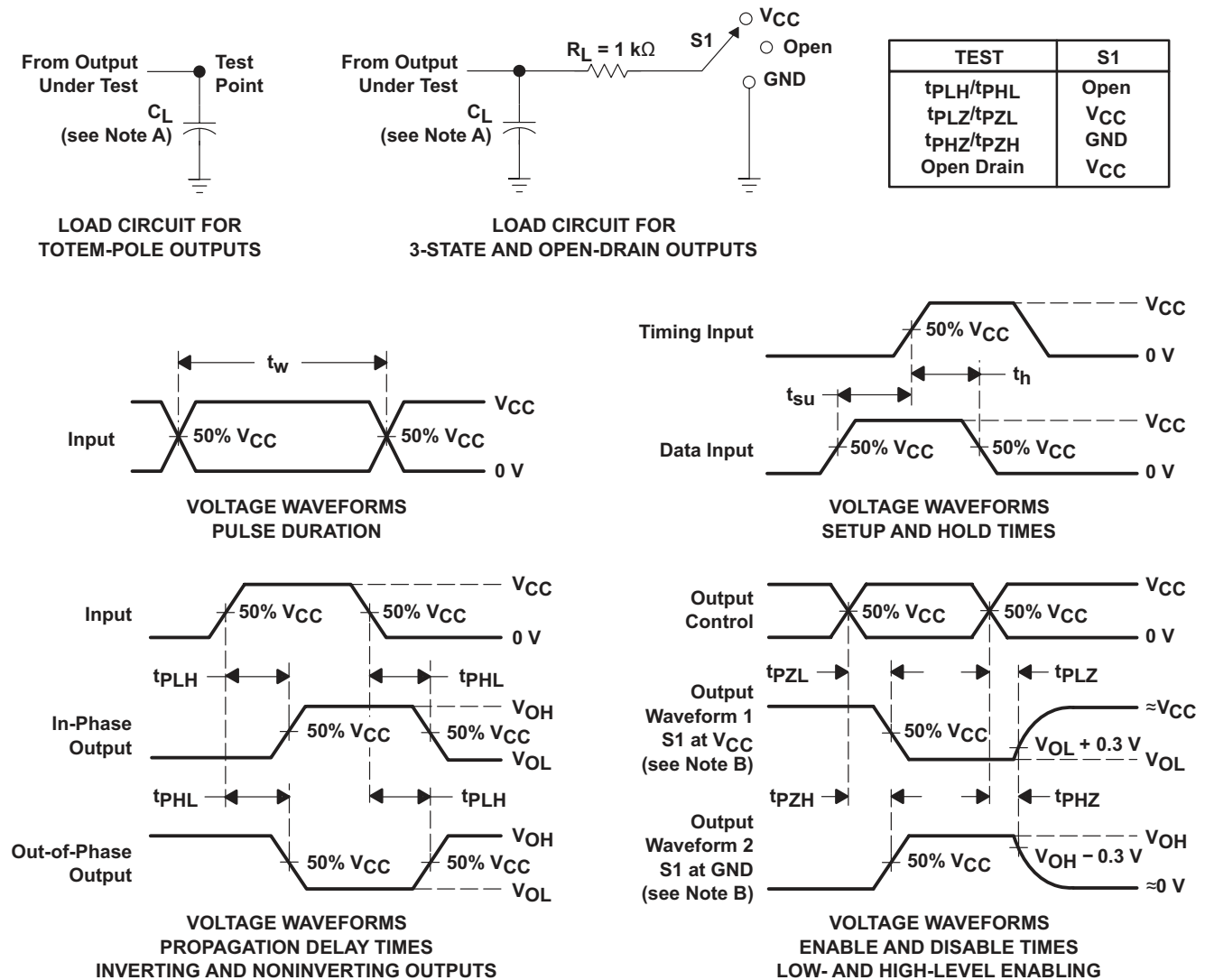

NOTES: A.  $C_L$  includes probe and jig capacitance.

B. Waveform 1 is for an output with internal conditions such that the output is low except when disabled by the output control. Waveform 2 is for an output with internal conditions such that the output is high except when disabled by the output control.

C. All input pulses are supplied by generators having the following characteristics: PRR  $\leq 1\text{ MHz}$ ,  $Z_O = 50\ \Omega$ ,  $t_r \leq 3\text{ ns}$ ,  $t_f \leq 3\text{ ns}$ .

D. The outputs are measured one at a time with one input transition per measurement.

**Figure 4. Load Circuit and Voltage Waveforms**

## 8 Detailed Description

### 8.1 Overview

The SNx4AHC594 devices contain an 8-bit serial-in, parallel-out shift register that feeds an 8-bit D-type storage register. Separate clocks and direct overriding clear ( $\overline{\text{SRCLR}}$ ,  $\overline{\text{RCLR}}$ ) inputs are provided on the shift and storage registers. A serial ( $Q_H$ ) output is provided for cascading purposes. The shift register (SRCLK) and storage register (RCLK) clocks are positive-edge triggered. If the clocks are tied together, the shift register always is one clock pulse ahead of the storage register.

### 8.2 Functional Block Diagram

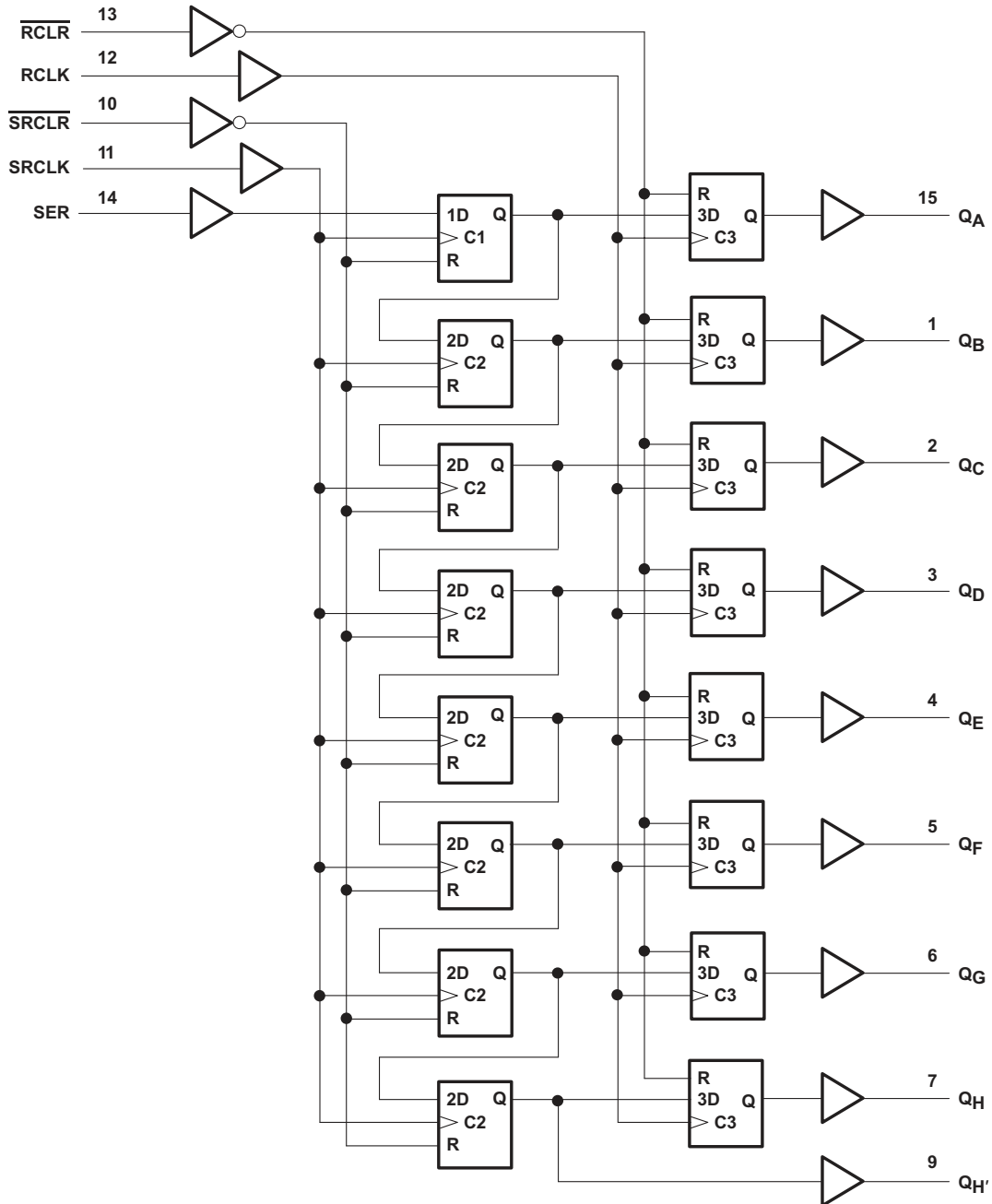

Pin numbers shown are for the D, DB, J, N, NS, PW, and W packages.

### 8.3 Feature Description

- Allows for down translation
  - Inputs are tolerant up to 5.5 V
- Slow edges for reduced noise
- Low power

### 8.4 Device Functional Modes

**Table 1. Function Table**

INPUTS					FUNCTION
SER	SRCLK	SRCLR	RCLK	RCLR	
X	X	L	X	X	Shift register is cleared.
L	↑	H	X	X	First stage of shift register goes low. Other stages store the data of previous stage, respectively.
H	↑	H	X	X	First stage of shift register goes high. Other stages store the data of previous stage, respectively.
L	↓	H	X	X	Shift register state is not changed.
X	X	X	X	L	Storage register is cleared.
X	X	X	↑	H	Shift register data is stored in the storage register.
X	X	X	↓	H	Storage register state is not changed.

## 9 Application and Implementation

### 9.1 Application Information

The SN74AHC594 is a low-drive CMOS device that can be used for a multitude of bus interface type applications where output ringing is a concern. The low drive and slow edge rates will minimize overshoot and undershoot on the outputs. The inputs accept voltages up to 5.5 V allowing down translation to the  $V_{CC}$  level. Figure 6 shows how the slower edges can reduce ringing on the output compared to higher drive parts like AC.

### 9.2 Typical Application

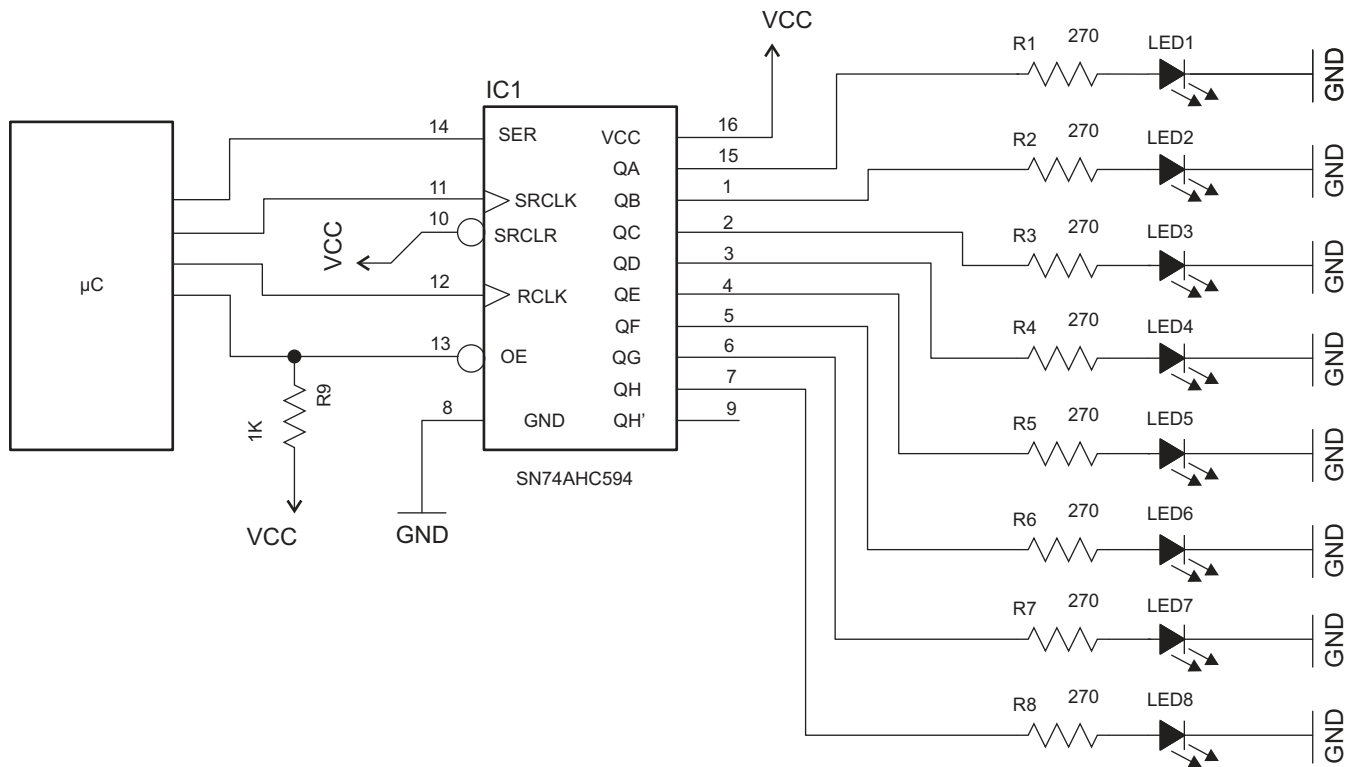

**Figure 5. Typical Application Schematic**

#### 9.2.1 Design Requirements

This device uses CMOS technology and has balanced output drive. Care should be taken to avoid bus contention because it can drive currents that would exceed maximum limits. Outputs can be combined to produce higher drive but the high drive will also create faster edges into light loads, so routing and load conditions should be considered to prevent ringing.

#### 9.2.2 Detailed Design Procedure

1. Recommended Input Conditions
  - Rise time and fall time specs: See  $(\Delta t/\Delta V)$  in the [Recommended Operating Conditions](#) table.
  - Specified high and low levels: See  $(V_{IH}$  and  $V_{IL})$  in the [Recommended Operating Conditions](#) table.
  - Inputs are overvoltage tolerant allowing them to go as high as 5.5 V at any valid  $V_{CC}$ .
2. Recommend Output Conditions
  - Load currents should not exceed 25 mA per output and 75 mA total for the part.
  - Outputs should not be pulled above  $V_{CC}$ .

## Typical Application (continued)

### 9.2.3 Application Curves

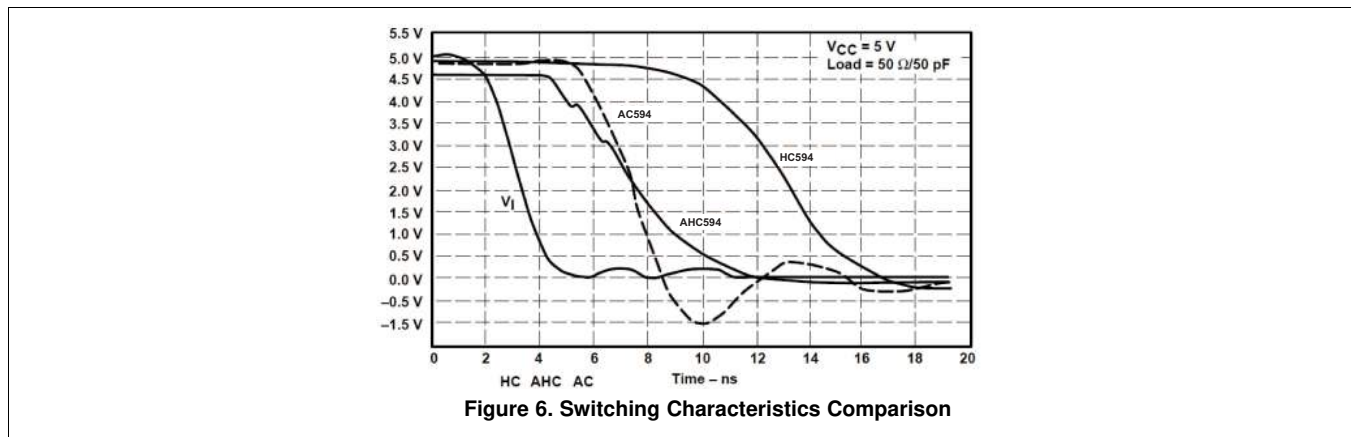

## 10 Power Supply Recommendations

The power supply can be any voltage between the MIN and MAX supply voltage rating located in the [Recommended Operating Conditions](#) table.

Each  $V_{CC}$  pin should have a good bypass capacitor to prevent power disturbance. For devices with a single supply, 0.1  $\mu\text{F}$  is recommended; if there are multiple  $V_{CC}$  pins, then 0.01  $\mu\text{F}$  or 0.022  $\mu\text{F}$  is recommended for each power pin. It is acceptable to parallel multiple bypass caps to reject different frequencies of noise. A 0.1  $\mu\text{F}$  and a 1  $\mu\text{F}$  are commonly used in parallel. The bypass capacitor should be installed as close to the power pin as possible for best results.

## 11 Layout

### 11.1 Layout Guidelines

When using multiple-bit logic devices, inputs should never float.

In many cases, functions or parts of functions of digital logic devices are unused, for example, when only two inputs of a triple-input AND gate are used or only 3 of the 4 buffer gates are used. Such input pins should not be left unconnected because the undefined voltages at the outside connections result in undefined operational states. [Figure 7](#) specifies the rules that must be observed under all circumstances. All unused inputs of digital logic devices must be connected to a high or low bias to prevent them from floating. The logic level that should be applied to any particular unused input depends on the function of the device. Generally they will be tied to GND or  $V_{CC}$ , whichever makes more sense or is more convenient. It is generally acceptable to float outputs, unless the part is a transceiver. If the transceiver has an output enable pin, it will disable the output section of the part when asserted. This will not disable the input section of the IOs, so they cannot float when disabled.

### 11.2 Layout Example

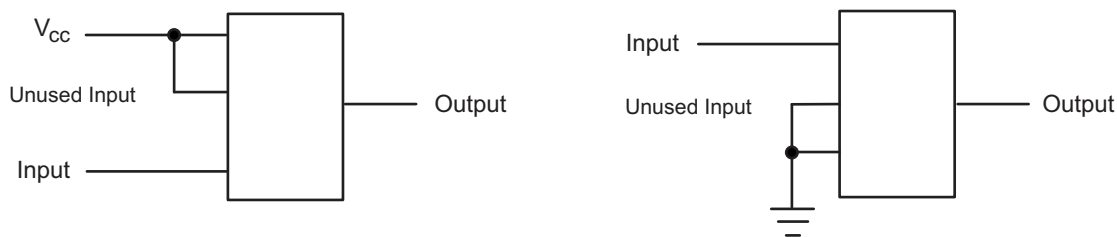

**Figure 7. Layout Diagram**

## 12 Device and Documentation Support

### 12.1 Related Links

The table below lists quick access links. Categories include technical documents, support and community resources, tools and software, and quick access to sample or buy.

**Table 2. Related Links**

PARTS	PRODUCT FOLDER	SAMPLE & BUY	TECHNICAL DOCUMENTS	TOOLS & SOFTWARE	SUPPORT & COMMUNITY
SN54AHC594	<a href="#">Click here</a>	<a href="#">Click here</a>	<a href="#">Click here</a>	<a href="#">Click here</a>	<a href="#">Click here</a>
SN74AHC594	<a href="#">Click here</a>	<a href="#">Click here</a>	<a href="#">Click here</a>	<a href="#">Click here</a>	<a href="#">Click here</a>

### 12.2 Trademarks

All trademarks are the property of their respective owners.

### 12.3 Electrostatic Discharge Caution



These devices have limited built-in ESD protection. The leads should be shorted together or the device placed in conductive foam during storage or handling to prevent electrostatic damage to the MOS gates.

### 12.4 Glossary

[SLYZ022](#) — *TI Glossary*.

This glossary lists and explains terms, acronyms, and definitions.

## 13 Mechanical, Packaging, and Orderable Information

The following pages include mechanical, packaging, and orderable information. This information is the most current data available for the designated devices. This data is subject to change without notice and revision of this document. For browser-based versions of this data sheet, refer to the left-hand navigation.

**PACKAGING INFORMATION**

Orderable Device	Status (1)	Package Type	Package Drawing	Pins	Package Qty	Eco Plan (2)	Lead finish/ Ball material (6)	MSL Peak Temp (3)	Op Temp (°C)	Device Marking (4/5)	Samples
SN74AHC594D	LIFEBUY	SOIC	D	16	40	RoHS & Green	NIPDAU	Level-1-260C-UNLIM	-40 to 125	AHC594	
SN74AHC594DBR	ACTIVE	SSOP	DB	16	2000	RoHS & Green	NIPDAU	Level-1-260C-UNLIM	-40 to 125	HA594	Samples
SN74AHC594DG4	LIFEBUY	SOIC	D	16	40	RoHS & Green	NIPDAU	Level-1-260C-UNLIM	-40 to 125	AHC594	
SN74AHC594DR	ACTIVE	SOIC	D	16	2500	RoHS & Green	NIPDAU	Level-1-260C-UNLIM	-40 to 125	AHC594	Samples
SN74AHC594DRG4	ACTIVE	SOIC	D	16	2500	RoHS & Green	NIPDAU	Level-1-260C-UNLIM	-40 to 125	AHC594	Samples
SN74AHC594N	ACTIVE	PDIP	N	16	25	RoHS & Green	NIPDAU	N / A for Pkg Type	-40 to 125	SN74AHC594N	Samples
SN74AHC594NSR	ACTIVE	SO	NS	16	2000	RoHS & Green	NIPDAU	Level-1-260C-UNLIM	-40 to 125	AHC594	Samples
SN74AHC594PWR	ACTIVE	TSSOP	PW	16	2000	RoHS & Green	NIPDAU	Level-1-260C-UNLIM	-40 to 125	HA594	Samples
SN74AHC594PWRG4	ACTIVE	TSSOP	PW	16	2000	RoHS & Green	NIPDAU	Level-1-260C-UNLIM	-40 to 125	HA594	Samples

(1) The marketing status values are defined as follows:

**ACTIVE:** Product device recommended for new designs.

**LIFEBUY:** TI has announced that the device will be discontinued, and a lifetime-buy period is in effect.

**NRND:** Not recommended for new designs. Device is in production to support existing customers, but TI does not recommend using this part in a new design.

**PREVIEW:** Device has been announced but is not in production. Samples may or may not be available.

**OBSOLETE:** TI has discontinued the production of the device.

(2) **RoHS:** TI defines "RoHS" to mean semiconductor products that are compliant with the current EU RoHS requirements for all 10 RoHS substances, including the requirement that RoHS substance do not exceed 0.1% by weight in homogeneous materials. Where designed to be soldered at high temperatures, "RoHS" products are suitable for use in specified lead-free processes. TI may reference these types of products as "Pb-Free".

**RoHS Exempt:** TI defines "RoHS Exempt" to mean products that contain lead but are compliant with EU RoHS pursuant to a specific EU RoHS exemption.

**Green:** TI defines "Green" to mean the content of Chlorine (Cl) and Bromine (Br) based flame retardants meet JS709B low halogen requirements of <=1000ppm threshold. Antimony trioxide based flame retardants must also meet the <=1000ppm threshold requirement.

(3) MSL, Peak Temp. - The Moisture Sensitivity Level rating according to the JEDEC industry standard classifications, and peak solder temperature.

(4) There may be additional marking, which relates to the logo, the lot trace code information, or the environmental category on the device.

(5) Multiple Device Markings will be inside parentheses. Only one Device Marking contained in parentheses and separated by a "~" will appear on a device. If a line is indented then it is a continuation of the previous line and the two combined represent the entire Device Marking for that device.



<sup>(6)</sup> Lead finish/Ball material - Orderable Devices may have multiple material finish options. Finish options are separated by a vertical ruled line. Lead finish/Ball material values may wrap to two lines if the finish value exceeds the maximum column width.

**Important Information and Disclaimer:**The information provided on this page represents TI's knowledge and belief as of the date that it is provided. TI bases its knowledge and belief on information provided by third parties, and makes no representation or warranty as to the accuracy of such information. Efforts are underway to better integrate information from third parties. TI has taken and continues to take reasonable steps to provide representative and accurate information but may not have conducted destructive testing or chemical analysis on incoming materials and chemicals. TI and TI suppliers consider certain information to be proprietary, and thus CAS numbers and other limited information may not be available for release.

In no event shall TI's liability arising out of such information exceed the total purchase price of the TI part(s) at issue in this document sold by TI to Customer on an annual basis.

**TAPE AND REEL INFORMATION**

**QUADRANT ASSIGNMENTS FOR PIN 1 ORIENTATION IN TAPE**

\*All dimensions are nominal

Device	Package Type	Package Drawing	Pins	SPQ	Reel Diameter (mm)	Reel Width W1 (mm)	A0 (mm)	B0 (mm)	K0 (mm)	P1 (mm)	W (mm)	Pin1 Quadrant
SN74AHC594DBR	SSOP	DB	16	2000	330.0	16.4	8.35	6.6	2.4	12.0	16.0	Q1
SN74AHC594DR	SOIC	D	16	2500	330.0	16.4	6.5	10.3	2.1	8.0	16.0	Q1
SN74AHC594NSR	SO	NS	16	2000	330.0	16.4	8.2	10.5	2.5	12.0	16.0	Q1
SN74AHC594PWR	TSSOP	PW	16	2000	330.0	12.4	6.9	5.6	1.6	8.0	12.0	Q1

## TAPE AND REEL BOX DIMENSIONS



\*All dimensions are nominal

Device	Package Type	Package Drawing	Pins	SPQ	Length (mm)	Width (mm)	Height (mm)
SN74AHC594DBR	SSOP	DB	16	2000	356.0	356.0	35.0
SN74AHC594DR	SOIC	D	16	2500	340.5	336.1	32.0
SN74AHC594NSR	SO	NS	16	2000	356.0	356.0	35.0
SN74AHC594PWR	TSSOP	PW	16	2000	356.0	356.0	35.0

**TUBE**

\*All dimensions are nominal

Device	Package Name	Package Type	Pins	SPQ	L (mm)	W (mm)	T (μm)	B (mm)
SN74AHC594D	D	SOIC	16	40	507	8	3940	4.32
SN74AHC594DG4	D	SOIC	16	40	507	8	3940	4.32
SN74AHC594N	N	PDIP	16	25	506	13.97	11230	4.32
SN74AHC594N	N	PDIP	16	25	506	13.97	11230	4.32



# PACKAGE OUTLINE

## NS0016A

### SOP - 2.00 mm max height

SOP

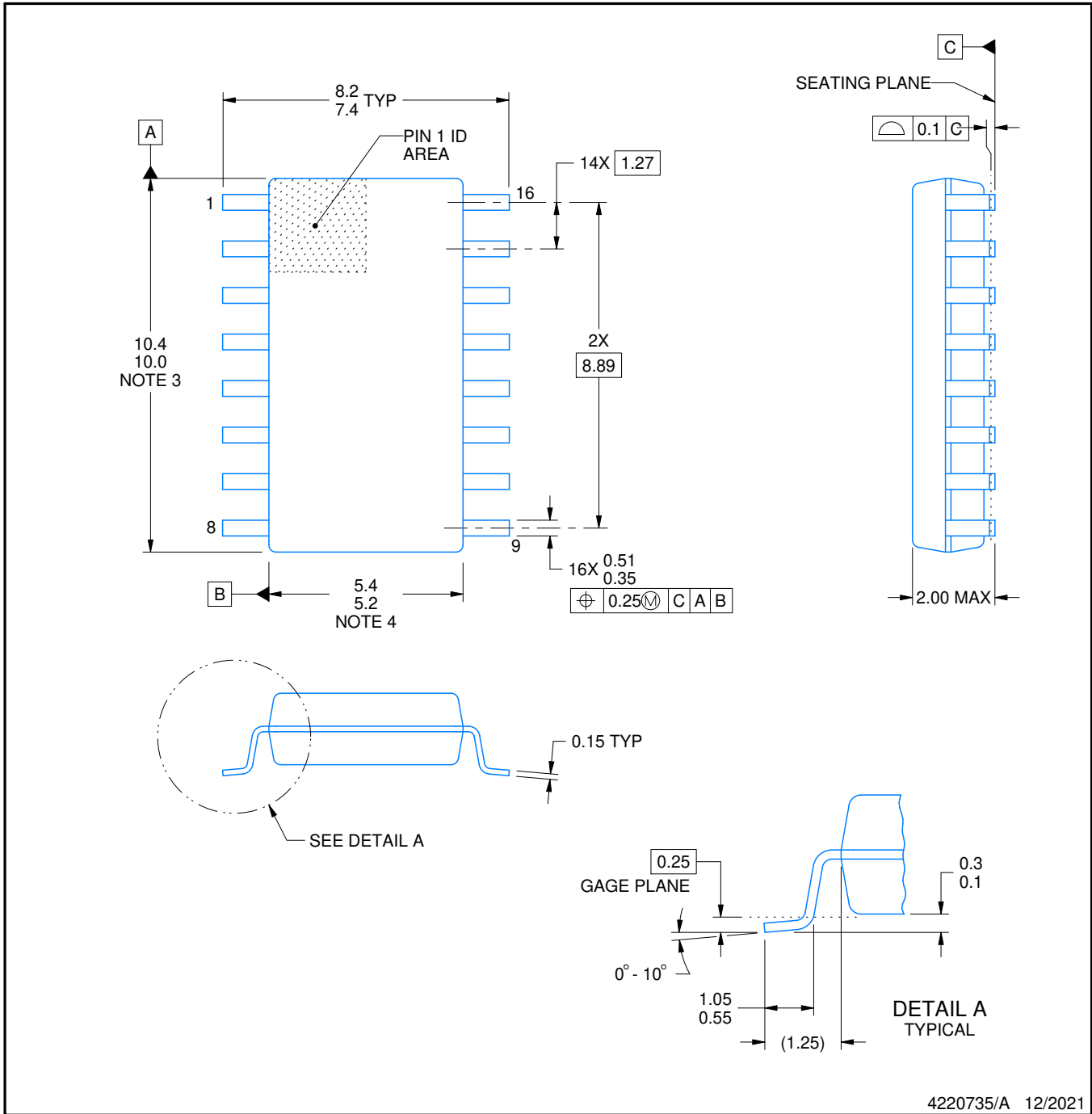

4220735/A 12/2021

#### NOTES:

1. All linear dimensions are in millimeters. Dimensions in parenthesis are for reference only. Dimensioning and tolerancing per ASME Y14.5M.
2. This drawing is subject to change without notice.
3. This dimension does not include mold flash, protrusions, or gate burrs. Mold flash, protrusions, or gate burrs shall not exceed 0.15 mm, per side.
4. This dimension does not include interlead flash. Interlead flash shall not exceed 0.25 mm, per side.

# EXAMPLE BOARD LAYOUT

NS0016A

SOP - 2.00 mm max height

SOP

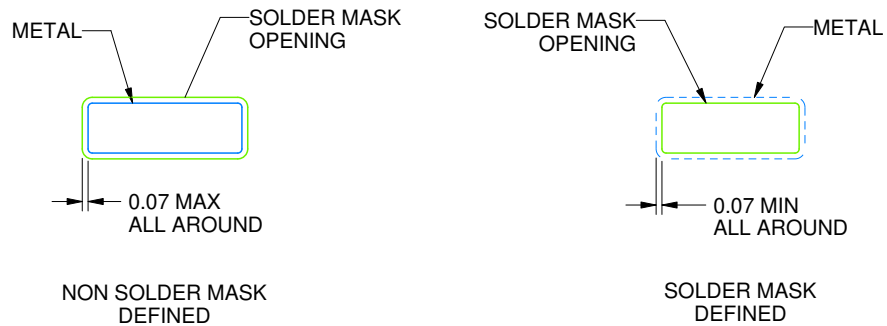
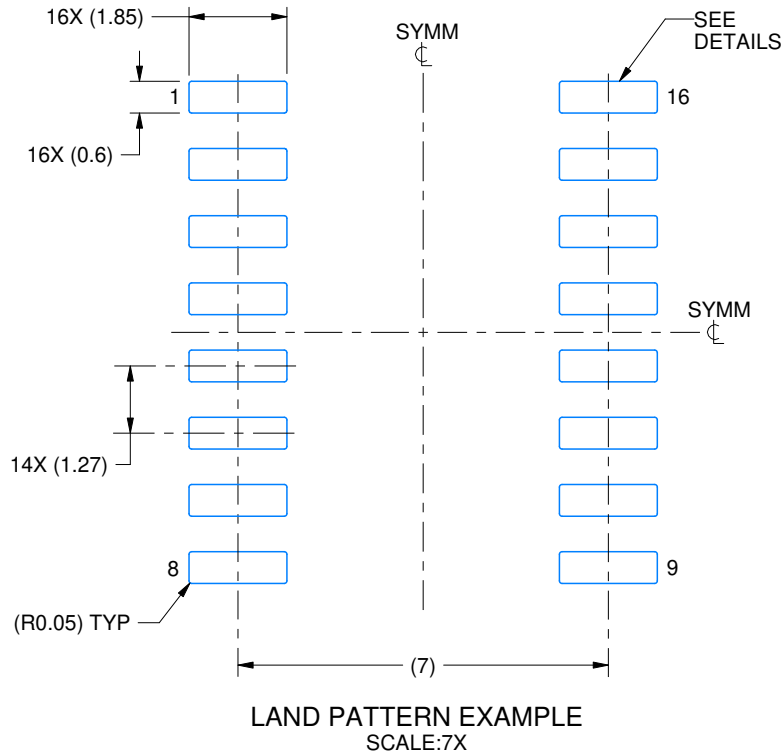

4220735/A 12/2021

NOTES: (continued)

5. Publication IPC-7351 may have alternate designs.

6. Solder mask tolerances between and around signal pads can vary based on board fabrication site.

# EXAMPLE STENCIL DESIGN

NS0016A

SOP - 2.00 mm max height

SOP

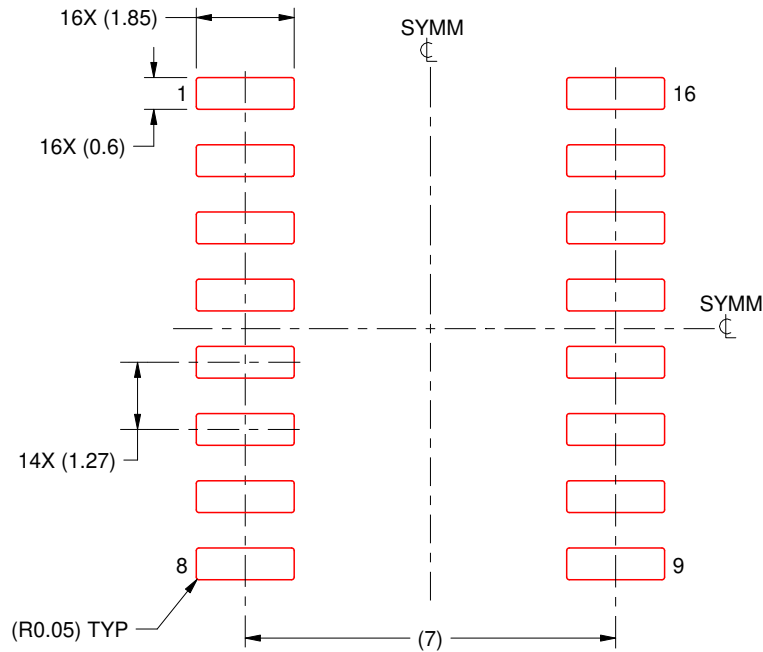

SOLDER PASTE EXAMPLE  
BASED ON 0.125 mm THICK STENCIL  
SCALE:7X

4220735/A 12/2021

NOTES: (continued)

7. Laser cutting apertures with trapezoidal walls and rounded corners may offer better paste release. IPC-7525 may have alternate design recommendations.
8. Board assembly site may have different recommendations for stencil design.

D (R-PDSO-G16)

PLASTIC SMALL OUTLINE

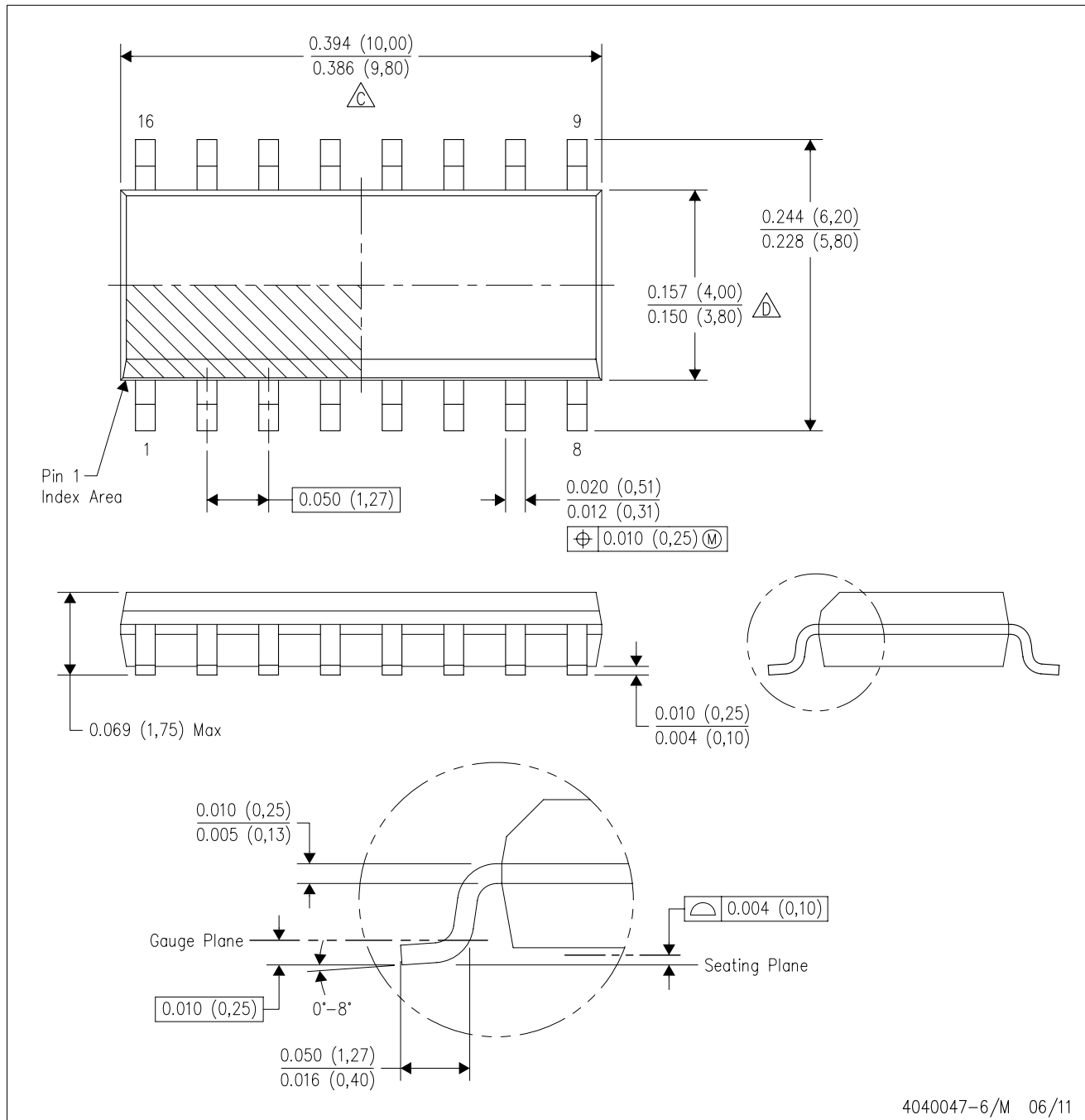

- NOTES:
- A. All linear dimensions are in inches (millimeters).
  - B. This drawing is subject to change without notice.
  - C. Body length does not include mold flash, protrusions, or gate burrs. Mold flash, protrusions, or gate burrs shall not exceed 0.006 (0,15) each side.
  - D. Body width does not include interlead flash. Interlead flash shall not exceed 0.017 (0,43) each side.
  - E. Reference JEDEC MS-012 variation AC.



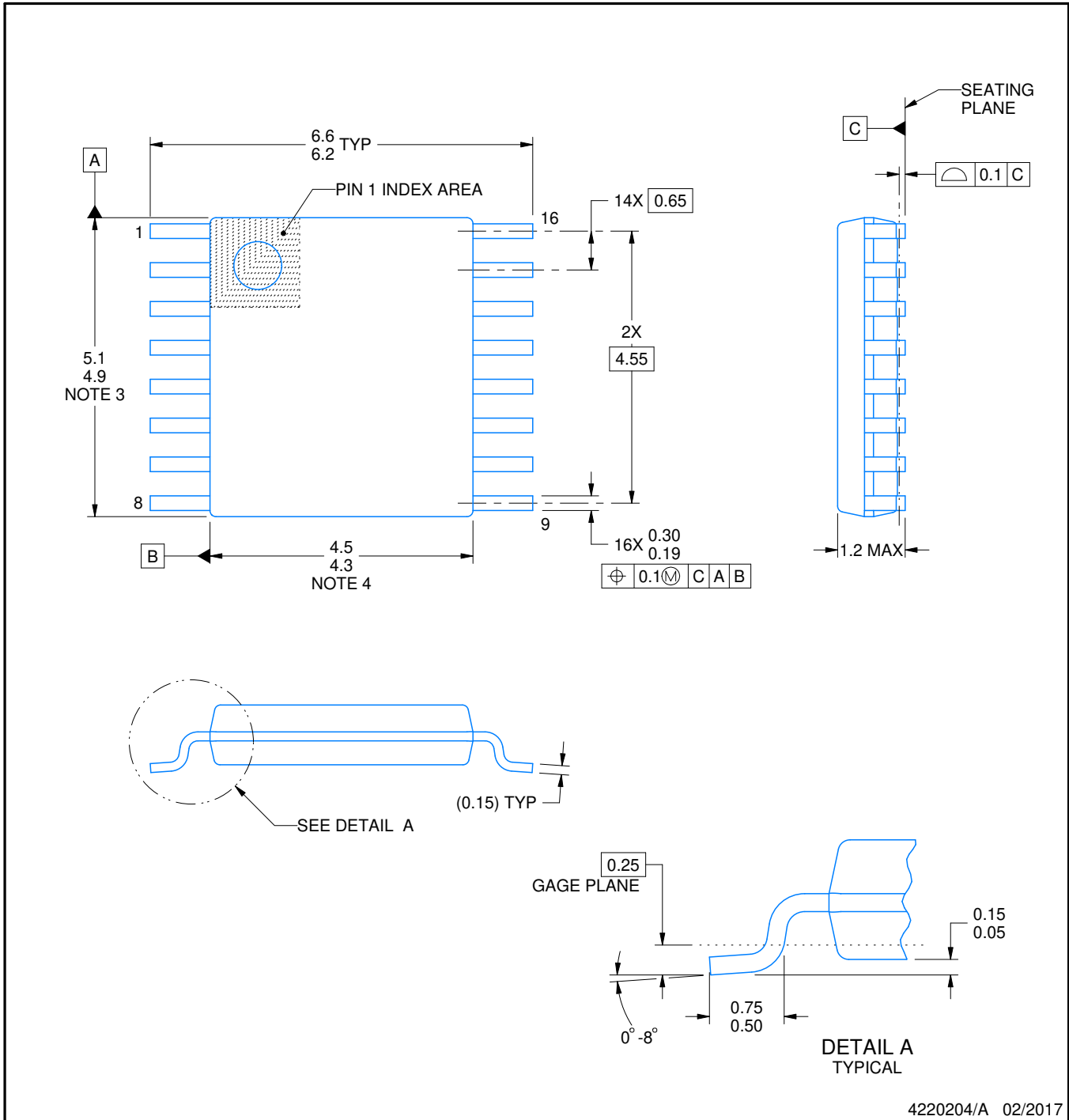

4220204/A 02/2017

NOTES:

1. All linear dimensions are in millimeters. Any dimensions in parenthesis are for reference only. Dimensioning and tolerancing per ASME Y14.5M.
2. This drawing is subject to change without notice.
3. This dimension does not include mold flash, protrusions, or gate burrs. Mold flash, protrusions, or gate burrs shall not exceed 0.15 mm per side.
4. This dimension does not include interlead flash. Interlead flash shall not exceed 0.25 mm per side.
5. Reference JEDEC registration MO-153.

# EXAMPLE BOARD LAYOUT

PW0016A

TSSOP - 1.2 mm max height

SMALL OUTLINE PACKAGE

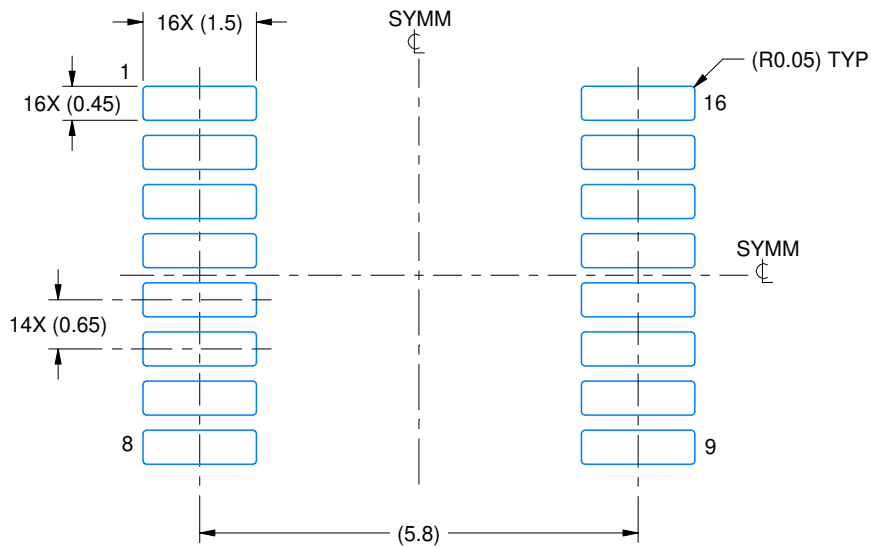

LAND PATTERN EXAMPLE  
EXPOSED METAL SHOWN  
SCALE: 10X

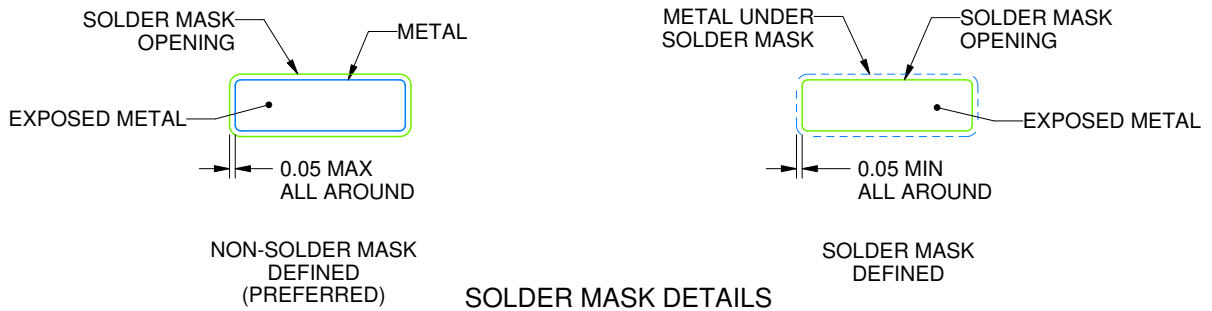

SOLDER MASK DETAILS

4220204/A 02/2017

NOTES: (continued)

- 6. Publication IPC-7351 may have alternate designs.
- 7. Solder mask tolerances between and around signal pads can vary based on board fabrication site.

# EXAMPLE STENCIL DESIGN

PW0016A

TSSOP - 1.2 mm max height

SMALL OUTLINE PACKAGE

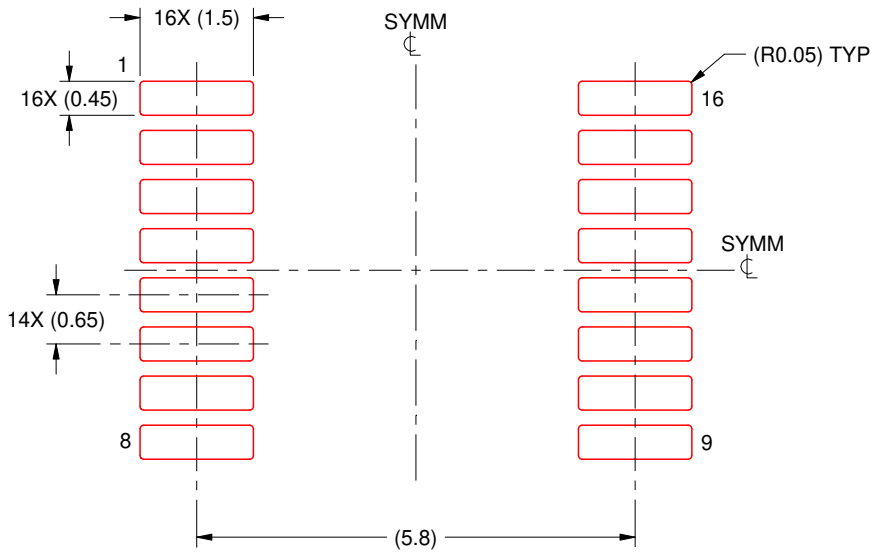

SOLDER PASTE EXAMPLE  
BASED ON 0.125 mm THICK STENCIL  
SCALE: 10X

4220204/A 02/2017

NOTES: (continued)

8. Laser cutting apertures with trapezoidal walls and rounded corners may offer better paste release. IPC-7525 may have alternate design recommendations.
9. Board assembly site may have different recommendations for stencil design.

# DB0016A



# PACKAGE OUTLINE

## SSOP - 2 mm max height

SMALL OUTLINE PACKAGE

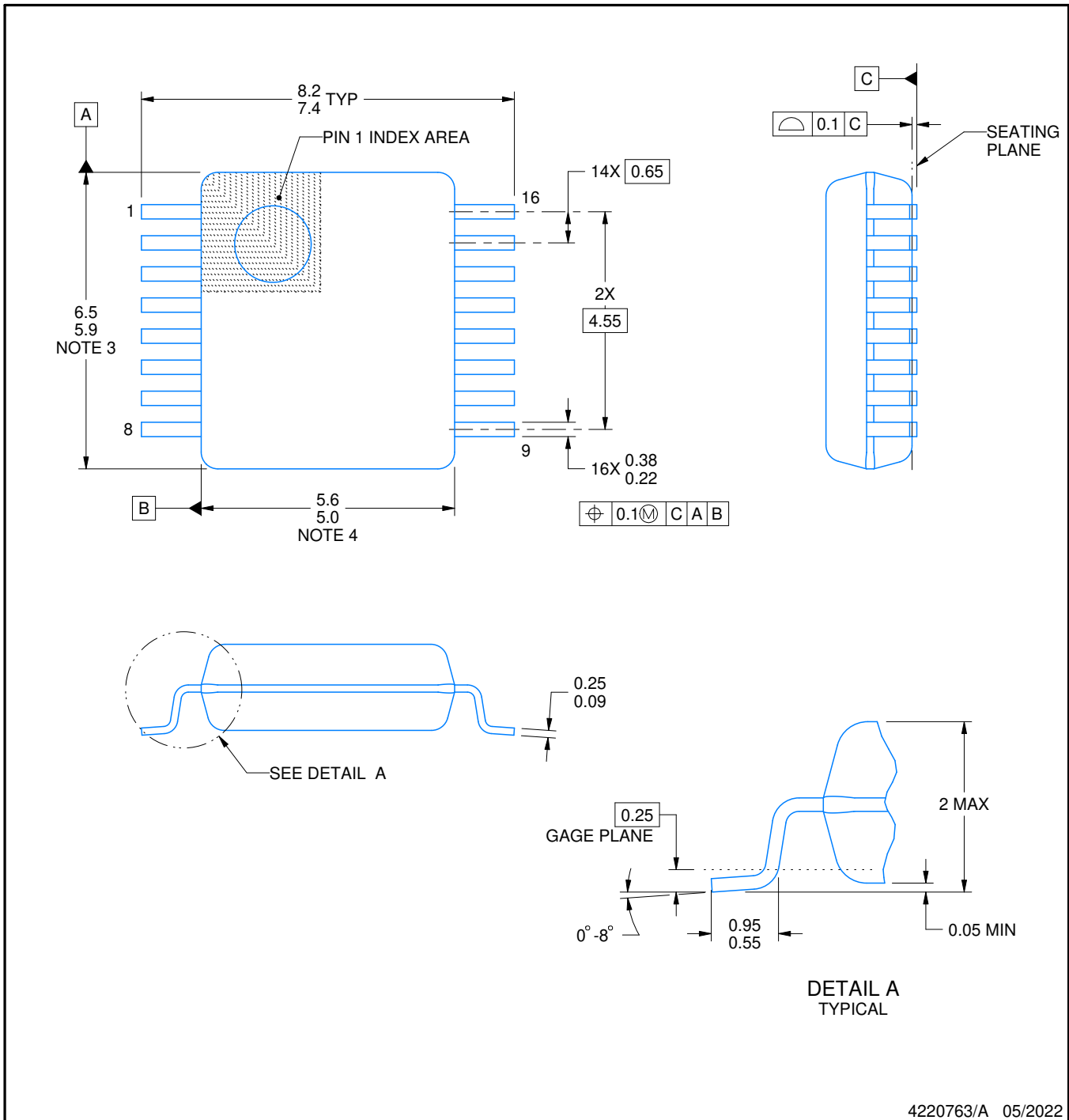

4220763/A 05/2022

**NOTES:**

1. All linear dimensions are in millimeters. Any dimensions in parenthesis are for reference only. Dimensioning and tolerancing per ASME Y14.5M.
2. This drawing is subject to change without notice.
3. This dimension does not include mold flash, protrusions, or gate burrs. Mold flash, protrusions, or gate burrs shall not exceed 0.15 mm per side.
4. Reference JEDEC registration MO-150.

# EXAMPLE BOARD LAYOUT

DB0016A

SSOP - 2 mm max height

SMALL OUTLINE PACKAGE

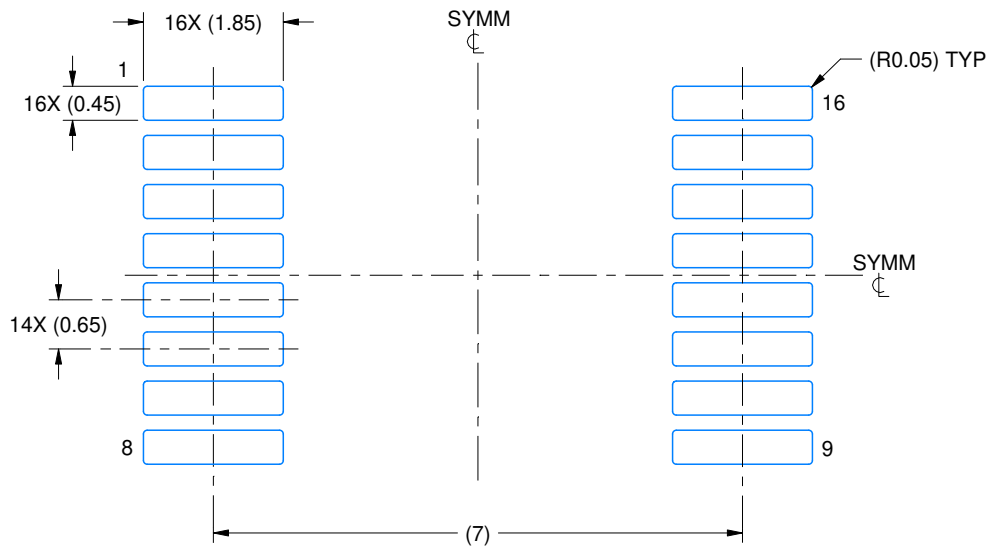

LAND PATTERN EXAMPLE  
EXPOSED METAL SHOWN  
SCALE: 10X

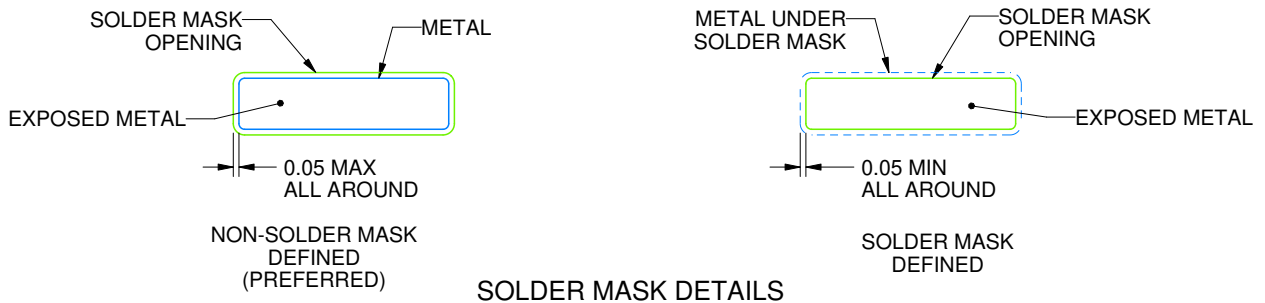

4220763/A 05/2022

NOTES: (continued)

5. Publication IPC-7351 may have alternate designs.
6. Solder mask tolerances between and around signal pads can vary based on board fabrication site.

# EXAMPLE STENCIL DESIGN

DB0016A

SSOP - 2 mm max height

SMALL OUTLINE PACKAGE

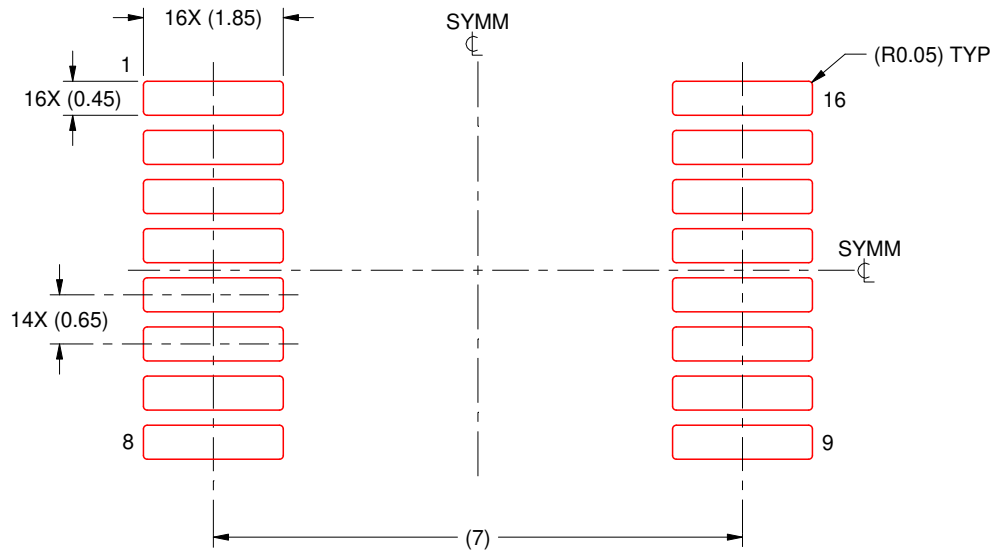

SOLDER PASTE EXAMPLE  
BASED ON 0.125 mm THICK STENCIL  
SCALE: 10X

4220763/A 05/2022

NOTES: (continued)

7. Laser cutting apertures with trapezoidal walls and rounded corners may offer better paste release. IPC-7525 may have alternate design recommendations.
8. Board assembly site may have different recommendations for stencil design.

# MECHANICAL DATA

NS (R-PDSO-G\*\*)

PLASTIC SMALL-OUTLINE PACKAGE

14-PINS SHOWN

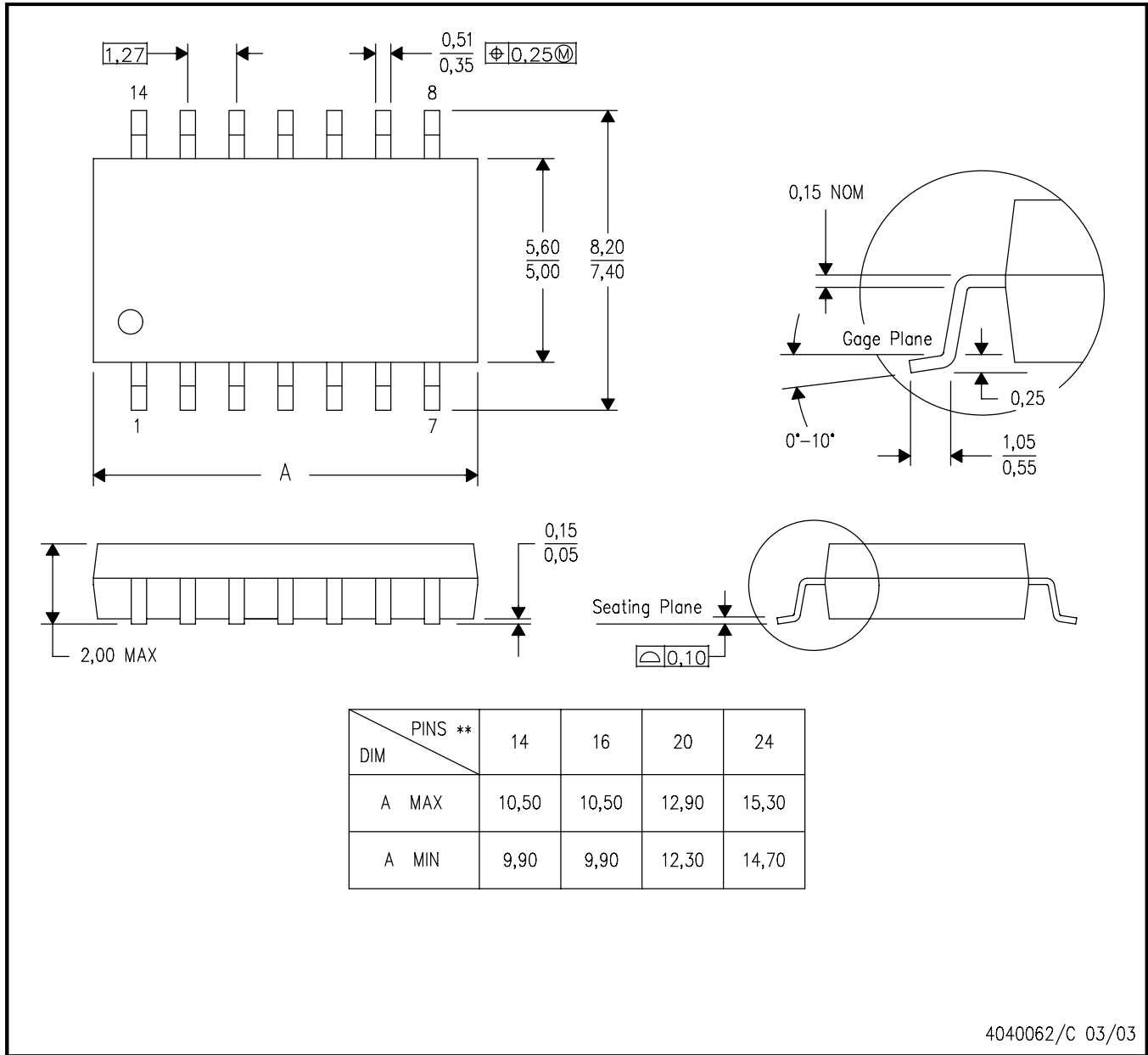

- NOTES:
- A. All linear dimensions are in millimeters.
  - B. This drawing is subject to change without notice.
  - C. Body dimensions do not include mold flash or protrusion, not to exceed 0,15.

N (R-PDIP-T\*\*)

PLASTIC DUAL-IN-LINE PACKAGE

16 PINS SHOWN



- NOTES:
- A. All linear dimensions are in inches (millimeters).
  - B. This drawing is subject to change without notice.
  - Falls within JEDEC MS-001, except 18 and 20 pin minimum body length (Dim A).
  - The 20 pin end lead shoulder width is a vendor option, either half or full width.



## IMPORTANT NOTICE AND DISCLAIMER

TI PROVIDES TECHNICAL AND RELIABILITY DATA (INCLUDING DATA SHEETS), DESIGN RESOURCES (INCLUDING REFERENCE DESIGNS), APPLICATION OR OTHER DESIGN ADVICE, WEB TOOLS, SAFETY INFORMATION, AND OTHER RESOURCES "AS IS" AND WITH ALL FAULTS, AND DISCLAIMS ALL WARRANTIES, EXPRESS AND IMPLIED, INCLUDING WITHOUT LIMITATION ANY IMPLIED WARRANTIES OF MERCHANTABILITY, FITNESS FOR A PARTICULAR PURPOSE OR NON-INFRINGEMENT OF THIRD PARTY INTELLECTUAL PROPERTY RIGHTS.

These resources are intended for skilled developers designing with TI products. You are solely responsible for (1) selecting the appropriate TI products for your application, (2) designing, validating and testing your application, and (3) ensuring your application meets applicable standards, and any other safety, security, regulatory or other requirements.

These resources are subject to change without notice. TI grants you permission to use these resources only for development of an application that uses the TI products described in the resource. Other reproduction and display of these resources is prohibited. No license is granted to any other TI intellectual property right or to any third party intellectual property right. TI disclaims responsibility for, and you will fully indemnify TI and its representatives against, any claims, damages, costs, losses, and liabilities arising out of your use of these resources.

TI's products are provided subject to [TI's Terms of Sale](#) or other applicable terms available either on [ti.com](https://www.ti.com) or provided in conjunction with such TI products. TI's provision of these resources does not expand or otherwise alter TI's applicable warranties or warranty disclaimers for TI products.

TI objects to and rejects any additional or different terms you may have proposed.

Mailing Address: Texas Instruments, Post Office Box 655303, Dallas, Texas 75265  
Copyright © 2023, Texas Instruments Incorporated