



**GD25D80C**

**DATASHEET**

**CONTENTS**

<b>1. FEATURES</b>	<b>4</b>
<b>2. GENERAL DESCRIPTION</b>	<b>5</b>
<b>3. MEMORY ORGANIZATION</b>	<b>7</b>
<b>4. DEVICE OPERATION</b>	<b>8</b>
<b>5. DATA PROTECTION</b>	<b>9</b>
<b>6. STATUS REGISTER</b>	<b>10</b>
<b>7. COMMANDS DESCRIPTION</b>	<b>11</b>
7.1. WRITE ENABLE (WREN) (06H)	13
7.2. WRITE DISABLE (WRDI) (04H)	13
7.3. READ STATUS REGISTER (RDSR) (05H)	14
7.4. WRITE STATUS REGISTER (WRSR) (01H)	14
7.5. READ DATA BYTES (READ) (03H)	15
7.6. READ DATA BYTES AT HIGHER SPEED (FAST READ) (0BH)	15
7.7. DUAL OUTPUT FAST READ (3BH)	16
7.8. PAGE PROGRAM (PP) (02H)	17
7.9. SECTOR ERASE (SE) (20H)	18
7.10. 32KB BLOCK ERASE (BE) (52H)	18
7.11. 64KB BLOCK ERASE (BE) (D8H)	19
7.12. CHIP ERASE (CE) (60/C7H)	19
7.13. DEEP POWER-DOWN (DP) (B9H)	20
7.14. RELEASE FROM DEEP POWER-DOWN / READ DEVICE ID (ABH)	21
7.15. READ MANUFACTURE ID/ DEVICE ID (REMS) (90H)	22
7.16. READ IDENTIFICATION (RDID) (9FH)	23
7.17. READ UNIQUE ID (4BH)	24
<b>8. ELECTRICAL CHARACTERISTICS</b>	<b>25</b>
8.1. POWER-ON TIMING	25
8.2. INITIAL DELIVERY STATE	25
8.3. ABSOLUTE MAXIMUM RATINGS	25
8.4. CAPACITANCE MEASUREMENT CONDITIONS	26
8.5. DC CHARACTERISTICS	27
8.6. AC CHARACTERISTICS	30
<b>9. ORDERING INFORMATION</b>	<b>34</b>
9.1. VALID PART NUMBERS	35
<b>10. PACKAGE INFORMATION</b>	<b>36</b>
10.1. PACKAGE SOP8 150MIL	36
10.2. PACKAGE SOP8 208MIL	37
10.3. PACKAGE TSSOP8 173MIL	38



**3.3V Uniform Sector  
Standard and Dual Serial Flash**

**GD25D80C**

---

10.4. PACKAGE USON8 (1.5*1.5MM) .....	39
10.5. PACKAGE USON8 (3*2MM, THICKNESS 0.45MM) .....	40
<b>11. REVISION HISTORY .....</b>	<b>41</b>

## 1. FEATURES

- ◆ 8M-bit Serial Flash
  - 1024K-byte
  - 256 bytes per programmable page
- ◆ Standard, Dual Output
  - Standard SPI: SCLK, CS#, SI, SO, WP#
  - Dual Output: SCLK, CS#, IO0, O1, WP#
- ◆ Clock Frequency
  - 100MHz for fast read with 30PF load
  - Dual Output Data transfer up to 160Mbps/s
- ◆ Software/Hardware Write Protection
  - Write protect all/portion of memory via software
  - Enable/Disable protection with WP# Pin
- ◆ Minimum 100,000 Program/Erase Cycles
- ◆ Data retention
  - 20-year data retention typical
- ◆ Fast Program/Erase Speed
  - Page Program time: 0.7ms typical
  - Sector Erase time: 100ms typical
  - Block Erase time: 0.3/0.5s typical
  - Chip Erase time: 8s typical
- ◆ Flexible Architecture
  - Uniform Sector of 4K-byte
  - Uniform Block of 32/64K-byte
- ◆ Low Power Consumption
  - 0.1uA typical standby current
  - 0.1uA typical power down current
- ◆ Advanced Security Features
  - 128-bit Unique ID for each device
- ◆ Single Power Supply Voltage
  - Full voltage range: 2.7~3.6V
- ◆ Package option
  - SOP8 150MIL
  - SOP8 208MIL
  - TSSOP8 173MIL
  - USON8 1.5\*1.5MM
  - USON8 3\*2MM

## 2. GENERAL DESCRIPTION

The GD25D80C (8M-bit) Serial flash supports the standard Serial Peripheral Interface (SPI), and supports the Dual Output: Serial Clock, Chip Select, Serial Data I/O0 (SI), O1 (SO). The Dual Output data is transferred with speed of 160Mbits/s.

### CONNECTION DIAGRAM

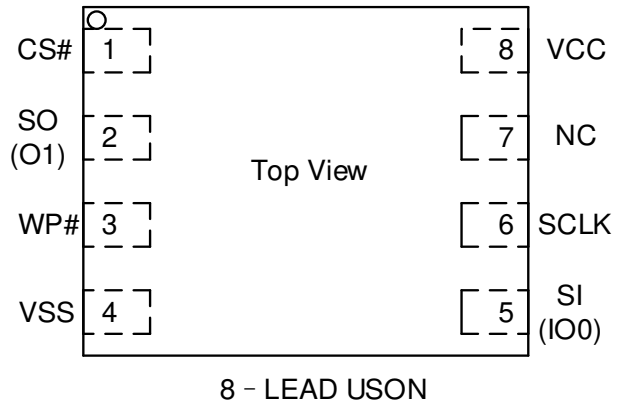
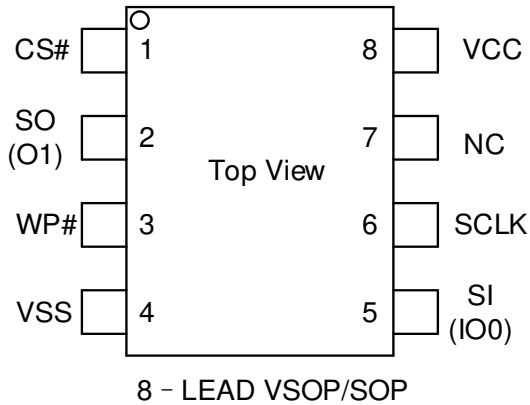

### PIN DESCRIPTION

Pin Name	I/O	Description
CS#	I	Chip Select Input
SO (O1)	O	Data Output (Data Output 1)
WP#	I	Write Protect Input
VSS		Ground
SI (IO0)	I/O	Data Input (Data Input Output 0)
SCLK	I	Serial Clock Input
NC		No Connection
VCC		Power Supply

Note: CS# must be driven high if chip is not selected. Please don't leave CS# floating any time after power is on.

**BLOCK DIAGRAM**

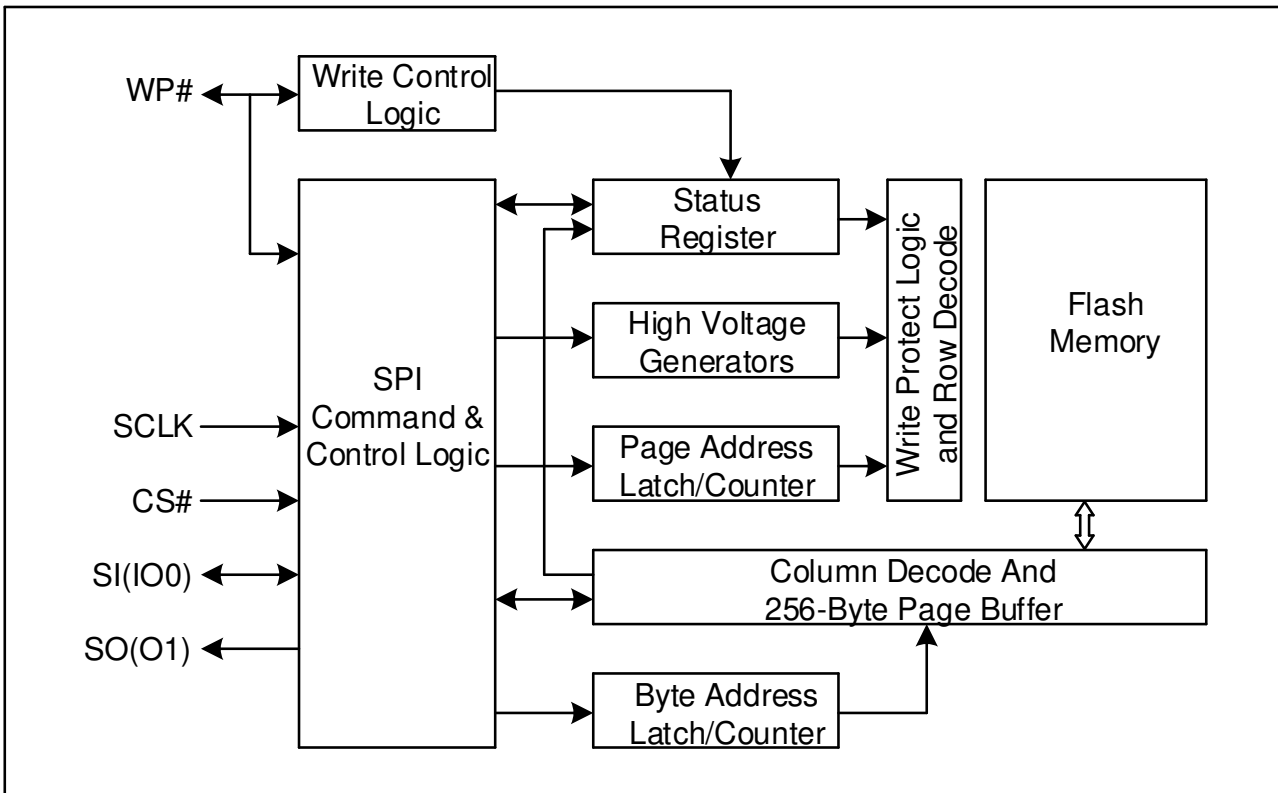

### 3. MEMORY ORGANIZATION

#### GD25D80C

Each device has	Each block has	Each sector has	Each page has	
1M	64/32K	4K	256	bytes
4K	256/128	16	-	pages
256	16/8	-	-	sectors
16/32	-	-	-	blocks

#### UNIFORM BLOCK SECTOR ARCHITECTURE

##### GD25D80C 64K Bytes Block Sector Architecture

Block	Sector	Address range	
15	255	0FF000H	0FFFFFFH
	.....	.....	.....
	240	0F0000H	0F0FFFFH
14	239	0EF000H	0EFFFFFFH
	.....	.....	.....
	224	0E0000H	0E0FFFFH
.....	.....	.....	.....
	.....	.....	.....
	.....	.....	.....
.....	.....	.....	.....
	.....	.....	.....
	.....	.....	.....
2	47	02F000H	02FFFFFFH
	.....	.....	.....
	32	020000H	020FFFFH
1	31	01F000H	01FFFFFFH
	.....	.....	.....
	16	010000H	010FFFFH
0	15	00F000H	00FFFFFFH
	.....	.....	.....
	0	000000H	000FFFFH

## **4. DEVICE OPERATION**

### **SPI Mode**

#### **Standard SPI**

The GD25D80C features a serial peripheral interface on 4 signals bus: Serial Clock (SCLK), Chip Select (CS#), Serial Data Input (SI) and Serial Data Output (SO). Both SPI bus mode 0 and 3 are supported. Input data is latched on the rising edge of SCLK and data shifts out on the falling edge of SCLK.

#### **Dual SPI**

The GD25D80C supports Dual Output operation when using the “Dual Output Fast Read” (3BH) commands. These commands allow data to be transferred to or from the device at twice the rate of the standard SPI. When using the Dual Output command the SI and SO pins become bidirectional I/O pins: IO0 and O1.



## 5. DATA PROTECTION

The GD25D80C provides the following data protection methods:

- ◆ Write Enable (WREN) command: The WREN command is set the Write Enable Latch bit (WEL). The WEL bit will reset to 0 in the following situations:
  - Power-Up
  - Write Disable (WRDI)
  - Write Status Register (WRSR)
  - Page Program (PP)
  - Sector Erase (SE) / Block Erase (BE) / Chip Erase (CE)
- ◆ Software Protection Mode: The Block Protect (BP2, BP1, BP0) bits define the section of the protected memory area which is read-only and unalterable.
- ◆ Hardware Protection Mode: WP# goes low to protect the BP0~BP2 bits and SRP bits.
- ◆ Deep Power-Down Mode: In Deep Power-Down Mode, all commands are ignored except the Release from Deep Power-Down Mode command.
- ◆ Write Inhibit Voltage (VWI): Device would reset automatically when VCC is below a certain threshold VWI.

**Table1. GD25D80C Protected area size**

Status Register Content			Memory Content			
BP2	BP1	BP0	Blocks	Addresses	Density	Portion
0	0	0	NONE	NONE	NONE	NONE
0	0	1	Sector 0 to 253	000000H-0FDFFFH	1016KB	Lower 254/256
0	1	0	Sector 0 to 251	000000H-0FBFFFH	1008KB	Lower 252/256
0	1	1	Sector 0 to 247	000000H-0F7FFFH	992KB	Lower 248/256
1	0	0	Sector 0 to 239	000000H-0EFFFFH	960KB	Lower 240/256
1	0	1	Sector 0 to 223	000000H-0DFFFFH	896KB	Lower 224/256
1	1	0	Sector 0 to 191	000000H-0BFFFFH	768KB	Lower 192/256
1	1	1	All	000000H-0FFFFFFH	1024KB	ALL

## 6. STATUS REGISTER

S7	S6	S5	S4	S3	S2	S1	S0
SRP	Reserved	Reserved	BP2	BP1	BP0	WEL	WIP

The status and control bits of the Status Register are as follows:

### WIP bit.

The Write In Progress (WIP) bit indicates whether the memory is busy in program/erase/write status register progress. When WIP bit is set to 1, it means the device is busy in program/erase/write status register progress. when WIP bit is cleared to 0, it means the device is not in program/erase/write status register progress. The default value of WIP is 0.

### WEL bit.

The Write Enable Latch (WEL) bit indicates the status of the internal Write Enable Latch. When set to 1 the internal Write Enable Latch is set, when set to 0 the internal Write Enable Latch is reset and no Write Status Register, Program or Erase command is accepted. The default value of WEL is 0.

### BP2, BP1, BP0 bits.

The Block Protect (BP2, BP1, BP0) bits are non-volatile. They define the size of the area to be software protected against Program and Erase commands. These bits are written with the Write Status Register (WRSR) command. When the Block Protect (BP2, BP1, BP0) bits are set to 1, the relevant memory area (as defined in Table1).becomes protected against Page Program (PP), Sector Erase (SE) and Block Erase (BE) commands. The Block Protect (BP2, BP1, BP0) bits can be written provided that the Hardware Protected mode has not been set. The Chip Erase (CE) command is executed, if the Block Protect (BP2, BP1, BP0) bits are all 0. The default value of BP2:0 are 0s.

### SRP bit

The Status Register Protect (SRP) bit operates in conjunction with the Write Protect (WP#) signal. The Status Register Write Protect (SRP) bit and Write Protect (WP#) signal set the device to the Hardware Protected mode. When the Status Register Protect (SRP) bit is set to 1, and Write Protect (WP#) is driven Low. In this mode, the non-volatile bits of the Status Register(SRP, BP2, BP1, BP0) become read-only bits and the Write Status Register (WRSR) instruction is not execution. The default value of SRP is 0.

## 7. COMMANDS DESCRIPTION

All commands, addresses and data are shifted in and out of the device by the host system, with the most significant bit first. On the first rising edge of SCLK after CS# is driven low, the one-byte command code must be shifted into the device, with the most significant bit first on SI, and each bit being latched on the rising edges of SCLK.

See Table2, every command sequence starts with a one-byte command code. Depending on the command, this might be followed by address bytes, or data bytes, or dummy bytes. CS# must be driven high after the last bit of the command sequence has been completed.

For the command of Read, Fast Read, Read Status Register or Release from Deep Power-Down, and Read Device ID, the shifted-in command sequence is followed by a data-out sequence. All read instruction can be completed after any bit of the data-out sequence is being shifted out, and then CS# must be driven high to return to deselected status.

For the command of Page Program, Sector Erase, Block Erase, Chip Erase, Write Status Register, Write Enable, Write Disable or Deep Power-Down command, CS# must be driven high exactly at a byte boundary, which means the clock pulse number should be an exact multiple of eight. Otherwise the command is rejected to executed. Especially for Page Program command, if at any time the input end is not a completed byte, nothing will be written into the memory array, neither would WEL bit be reset.

**Table2. Commands**

Command Name	Byte 1	Byte 2	Byte 3	Byte 4	Byte 5	Byte 6	n-Bytes
Write Enable	06H						
Write Disable	04H						
Read Status Register	05H	(S7-S0)					(continuous)
Write Status Register	01H	S7-S0					
Read Data	03H	A23-A16	A15-A8	A7-A0	(D7-D0)	(Next byte)	(continuous)
Fast Read	0BH	A23-A16	A15-A8	A7-A0	dummy	(D7-D0)	(continuous)
Dual Output Fast Read	3BH	A23-A16	A15-A8	A7-A0	dummy	(D7-D0) <sup>(1)</sup>	(continuous)
Page Program	02 H	A23-A16	A15-A8	A7-A0	D7-D0	Next byte	
Sector Erase	20H	A23-A16	A15-A8	A7-A0			
Block Erase(32K)	52H	A23-A16	A15-A8	A7-A0			
Block Erase(64K)	D8H	A23-A16	A15-A8	A7-A0			
Chip Erase	C7/60H						
Deep Power-Down	B9H						
Release From Deep Power-Down, And Read Device ID	ABH	dummy	dummy	dummy	(DID7- DID0)		(continuous)
Release From Deep Power-Down	ABH						
Manufacturer/ Device ID	90H	00H	00H	00H	(MID7- MID0)	(DID7- DID0)	(continuous)
Read Identification	9FH	(MID7- MID0)	(JDID15- JDID8)	(JDID7- JDID0)			(continuous)
Read Unique ID	4BH	00H	00H	00H	dummy	(UID7- UID0)	(continuous)

NOTE:

1. Dual Output data

IO0 = (D6, D4, D2, D0)

O1 = (D7, D5, D3, D1)



**TABLE OF ID DEFINATION:**

**GD25D80C**

<b>Operation Code</b>	<b>M7-M0</b>	<b>ID15-ID8</b>	<b>ID7-ID0</b>
9FH	C8	40	14
90H	C8		13
ABH			13

### 7.1. Write Enable (WREN) (06H)

The Write Enable (WREN) command is for setting the Write Enable Latch (WEL) bit to 1. The Write Enable Latch (WEL) bit must be set prior to every Page Program (PP), Sector Erase (SE), Block Erase (BE), Chip Erase (CE) and Write Status Register (WRSR) command.

The Write Enable (WREN) command sequence: CS# goes low → sending the Write Enable command → CS# goes high.

**Figure1. Write Enable Sequence Diagram**

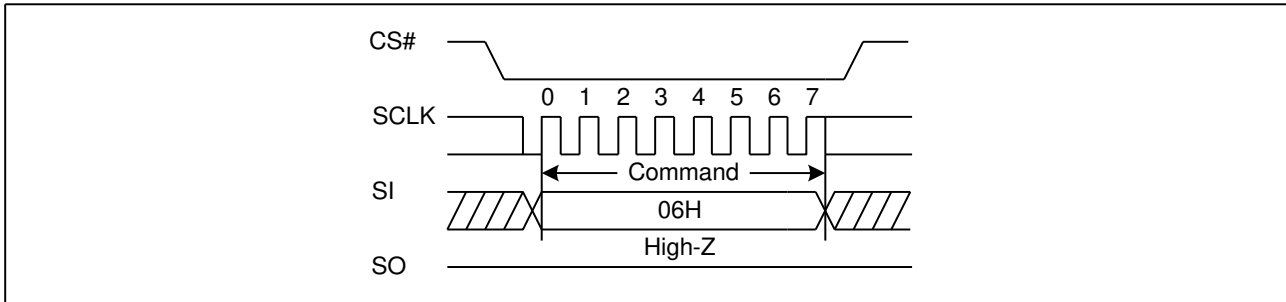

### 7.2. Write Disable (WRDI) (04H)

The Write Disable command is for resetting the Write Enable Latch (WEL) bit to 0. The WEL bit is reset by following condition: Power-up and upon completion of the Write Status Register, Page Program, Sector Erase, Block Erase and Chip Erase commands.

The Write Disable command sequence: CS# goes low → Sending the Write Disable command → CS# goes high.

**Figure2. Write Disable Sequence Diagram**

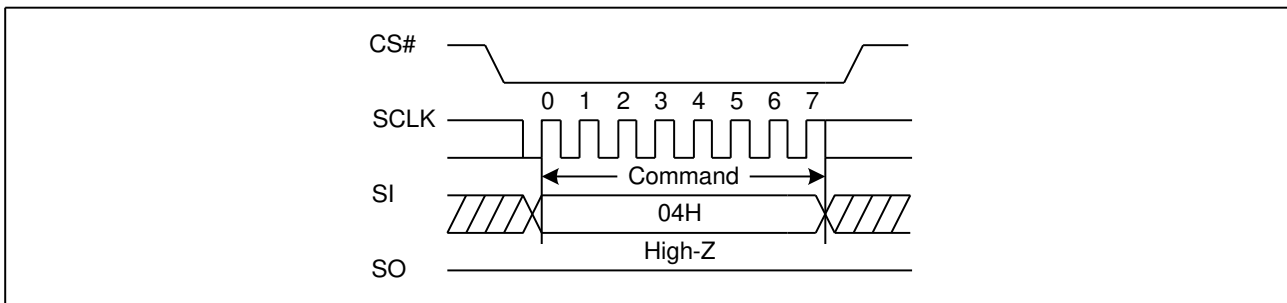

### 7.3. Read Status Register (RDSR) (05H)

The Read Status Register (RDSR) command is for reading the Status Register. The Status Register may be read at any time, even while a Program, Erase or Write Status Register cycle is in progress.

When one of these cycles is in progress, it is recommended to check the Write In Progress (WIP) bit before sending a new command to the device. It is also possible to read the Status Register continuously. For command code "05H", the SO will output Status Register bits S7~S0.

**Figure3. Read Status Register Sequence Diagram**

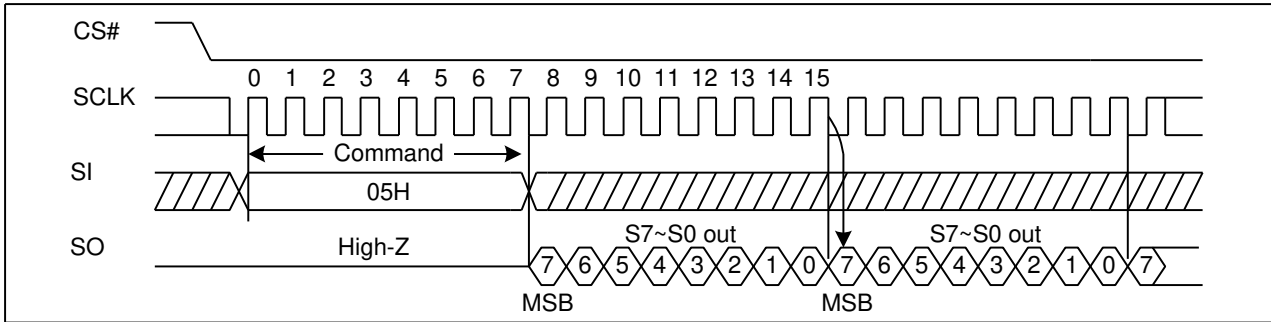

### 7.4. Write Status Register (WRSR) (01H)

The Write Status Register (WRSR) instruction allows new values to be written to the Status Register. A Write Enable (WREN) instruction must be executed previously to set the Write Enable Latch (WEL) bit, before it can be accepted.

The Write Status Register (WRSR) instruction is entered by driving Chip Select (CS#) Low, followed by the instruction code and the data byte on Serial Data Input (DI).

The Write Status Register (WRSR) instruction has no effect on S6, S5, S1 and S0 of the Status Register. S6 and S5 are always read as 0. Chip Select (CS#) must be driven High after the eighth bit of the data byte has been latched in. Otherwise, the Write Status Register (WRSR) instruction is not executed. As soon as Chip Select (CS#) is driven High, the self-timed Write Status Register cycle (the duration is tW) is initiated. While the Write Status Register cycle is in progress, reading Status Register to check the Write In Progress (WIP) bit is achievable.

The Write In Progress (WIP) bit is 1 during the self-timed Write Status Register cycle, and turn to 0 on the completion of the Write Status Register. When the cycle is completed, the Write Enable Latch (WEL) is reset to 0.

The Write Status Register (WRSR) instruction allows the user to change the values of the Block Protect (BP2, BP1, BP0) bits, which are utilized to define the size of the read-only area.

The Write Status Register (WRSR) instruction also allows the user to set or reset the Status Register Protect (SRP) bit in accordance with the Write Protect (WP#) signal, by setting which the device can enter into Hardware Protected Mode (HPM). The Write Status Register (WRSR) instruction is not executed once enter into the Hardware Protected Mode (HPM).

**Figure4. Write Status Register Sequence Diagram**

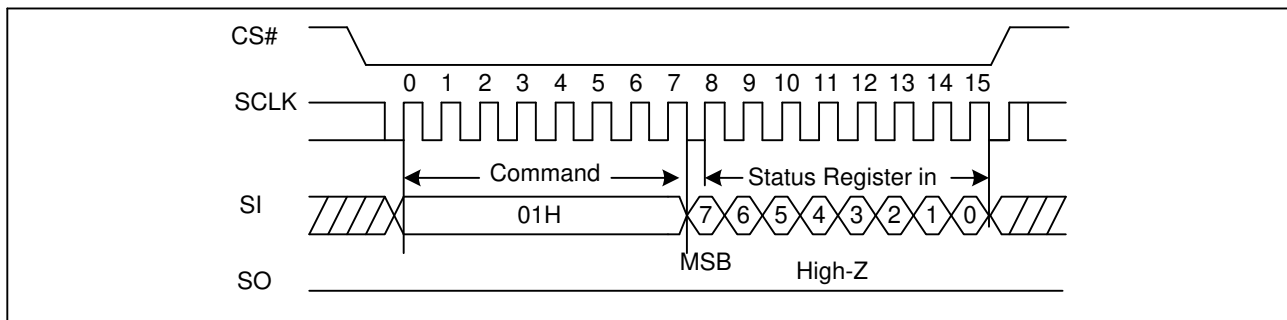

### 7.5. Read Data Bytes (READ) (03H)

The Read Data Bytes (READ) command is followed by a 3-byte address (A23-A0), and each bit being latched-in on the rising edge of SCLK. Then the memory content, at that address, is shifted out on SO, and each bit being shifted out, at a Max frequency  $f_R$ , on the falling edge of SCLK. The first byte addressed can be at any location. The address is automatically incremented to the next higher address after each byte of data is shifted out. The whole memory can, therefore, be read with a single Read Data Bytes (READ) command. Any Read Data Bytes (READ) command, while an Erase, Program or Write cycle is in progress, is rejected without having any effects on the cycle that is in progress.

**Figure5. Read Data Bytes Sequence Diagram**

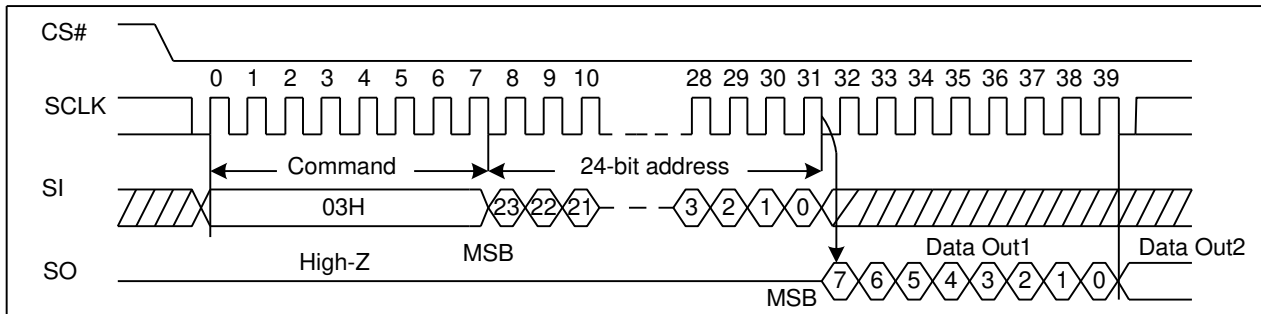

### 7.6. Read Data Bytes At Higher Speed (Fast Read) (0BH)

The Read Data Bytes at Higher Speed (Fast Read) command is for quickly reading data out. It is followed by a 3-byte address (A23-A0) and a dummy byte, and each bit being latched-in on the rising edge of SCLK. Then the memory content, at that address, is shifted out on SO, and each bit being shifted out, at a Max frequency  $f_c$ , on the falling edge of SCLK. The first byte addressed can be at any location. The address is automatically incremented to the next higher address after each byte of data is shifted out.

**Figure6. Read Data Bytes at Higher Speed Sequence Diagram**

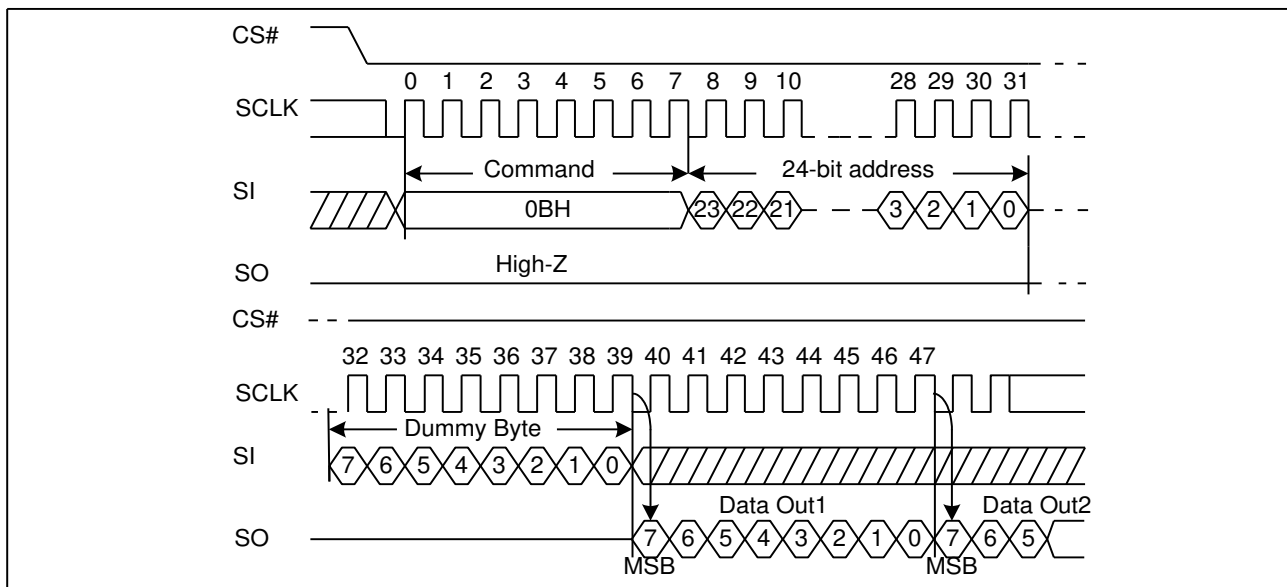

### 7.7. Dual Output Fast Read (3BH)

The Dual Output Fast Read command is followed by 3-byte address (A23-A0) and a dummy byte, and each bit being latched in on the rising edge of SCLK, then the memory contents are shifted out 2-bit per clock cycle from SI and SO. The command sequence is shown in followed Figure7. The first byte addressed can be at any location. The address is automatically incremented to the next higher address after each byte of data is shifted out.

**Figure7. Dual Output Fast Read Sequence Diagram**

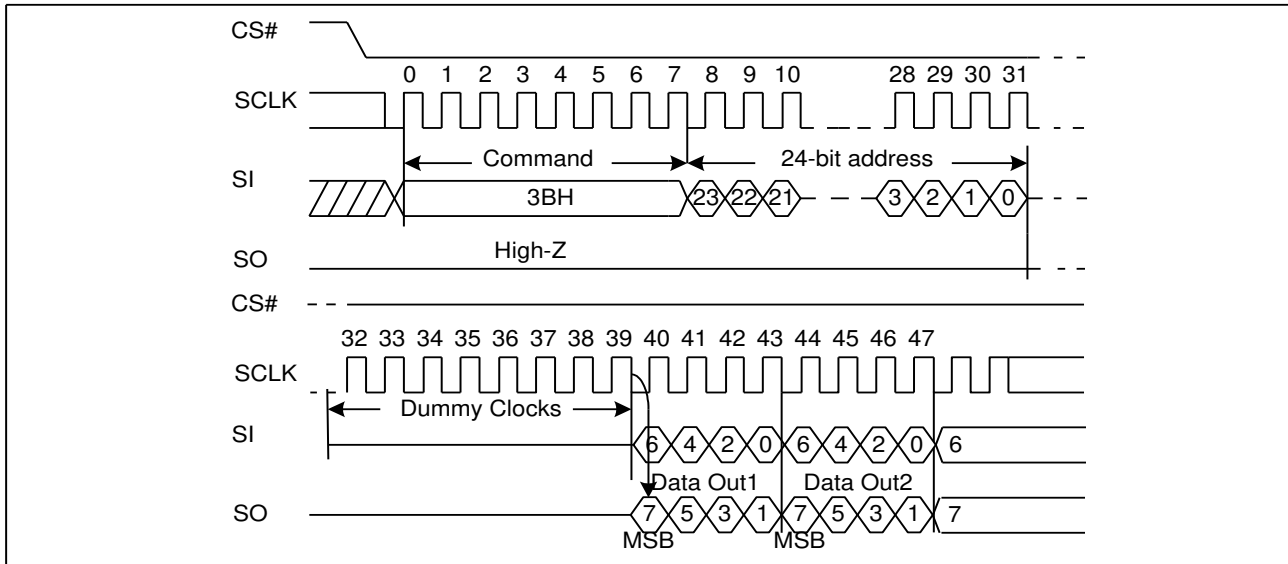



### 7.8. Page Program (PP) (02H)

The Page Program (PP) command is for programming the memory. A Write Enable (WREN) command must previously have been executed to set the Write Enable Latch (WEL) bit before sending the Page Program command.

The Page Program (PP) command is entered by driving CS# Low, followed by the command code, three address bytes and at least one data byte on SI.

If the 8 least significant address bits (A7-A0) are not all zero, all transmitted data that goes beyond the end of the current page are programmed from the start address of the same page (from the address whose 8 least significant bits (A7-A0) are all zero). CS# must be driven low for the entire duration of the sequence.

The Page Program command sequence: CS# goes low → sending Page Program command → 3-byte address on SI → at least 1 byte data on SI → CS# goes high. The command sequence is shown in Figure8.

If more than 256 bytes are sent to the device, previously latched data are discarded and the last 256 data bytes are guaranteed to be programmed correctly within the same page. If less than 256 data bytes are sent to device, they are correctly programmed at the requested addresses without having any effects on the other bytes of the same page. CS# must be driven high after the eighth bit of the last data byte has been latched in; otherwise the Page Program (PP) command is not executed.

As soon as CS# is driven high, the self-timed Page Program cycle (whose duration is  $t_{PP}$ ) is initiated. While the Page Program cycle is in progress, the Status Register may be read to check the value of the Write In Progress (WIP) bit. The Write In Progress (WIP) bit is 1 during the self-timed Page Program cycle, and is 0 when it is completed. At some unspecified time before the cycle is completed, the Write Enable Latch (WEL) bit is reset.

A Page Program (PP) command is not executed when it is applied to a page protected by the Block Protect (BP2, BP1, BP0).

**Figure8. Page Program Sequence Diagram**

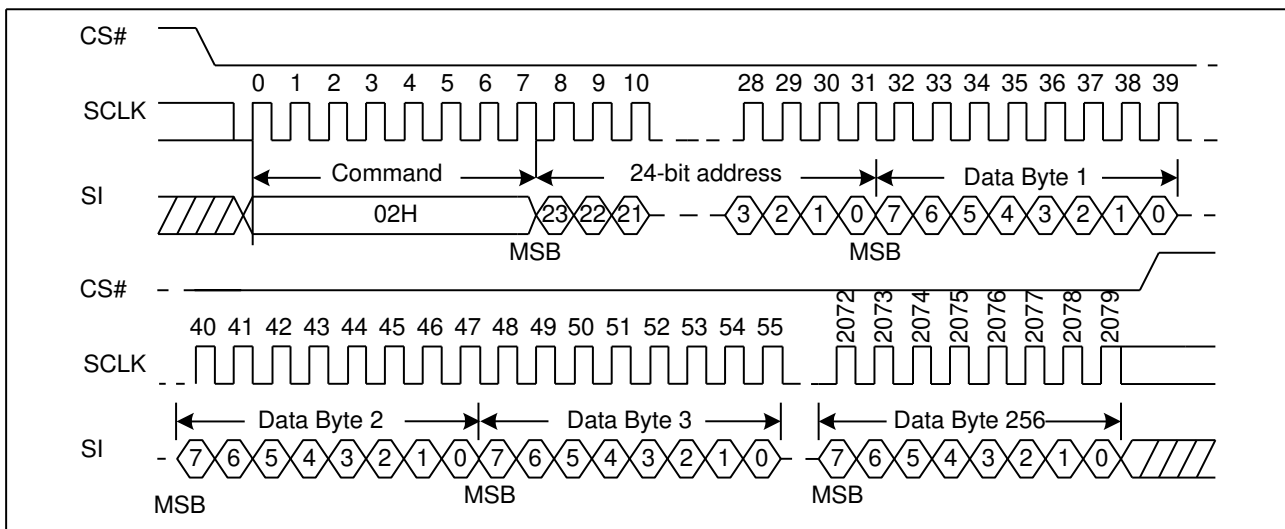

### 7.9. Sector Erase (SE) (20H)

The Sector Erase (SE) command is for erasing the all data of the specific sector. A Write Enable (WREN) command must previously have been executed to set the Write Enable Latch (WEL) bit. The Sector Erase (SE) command is entered by driving CS# low, followed by the command code, and 3-address byte on SI. Any address inside the sector is a valid address for the Sector Erase (SE) command. CS# must be driven low for the entire duration of the sequence.

The Sector Erase command sequence: CS# goes low → sending Sector Erase command → 3-byte address on SI → CS# goes high. The command sequence is shown in Figure9. CS# must be driven high after the eighth bit of the last address byte has been latched in; otherwise the Sector Erase (SE) command is not executed. As soon as CS# is driven high, the self-timed Sector Erase cycle (whose duration is  $t_{SE}$ ) is initiated. While the Sector Erase cycle is in progress, the Status Register is accessed to check the value of the Write In Progress (WIP) bit. The Write In Progress (WIP) bit is 1 during the self-timed Sector Erase cycle, and becomes 0 when it is completed. At some unspecified time before the cycle is completed, the Write Enable Latch (WEL) bit is reset. A Sector Erase (SE) command applied to a sector which is protected by the Block Protect (BP2, BP1, BP0) bit (see Table1) is not executed.

**Figure9. Sector Erase Sequence Diagram**

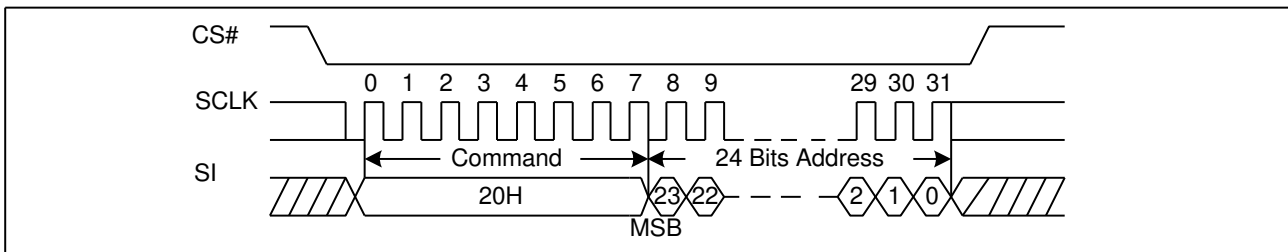

### 7.10. 32KB Block Erase (BE) (52H)

The 32KB Block Erase (BE) command is for erasing the all data of the chosen block. A Write Enable (WREN) command must previously have been executed to set the Write Enable Latch (WEL) bit. The 32KB Block Erase (BE) command is entered by driving CS# low, followed by the command code, and three address bytes on SI. Any address inside the block is a valid address for the 32KB Block Erase (BE) command. CS# must be driven low for the entire duration of the sequence.

The 32KB Block Erase command sequence: CS# goes low → sending 32KB Block Erase command → 3-byte address on SI → CS# goes high. The command sequence is shown in Figure10. CS# must be driven high after the eighth bit of the last address byte has been latched in; otherwise the 32KB Block Erase (BE) command is not executed. As soon as CS# is driven high, the self-timed Block Erase cycle (whose duration is  $t_{BE}$ ) is initiated. While the Block Erase cycle is in progress, the Status Register is accessed to check the value of the Write In Progress (WIP) bit. The Write In Progress (WIP) bit is 1 during the self-timed Block Erase cycle, and becomes 0 when it is completed. At some unspecified time before the cycle is completed, the Write Enable Latch (WEL) bit is reset. A 32KB Block Erase (BE) command applied to a block which is protected by the Block Protect (BP2, BP1, BP0) bits (see Table1) is not executed.

**Figure10. 32KB Block Erase Sequence Diagram**

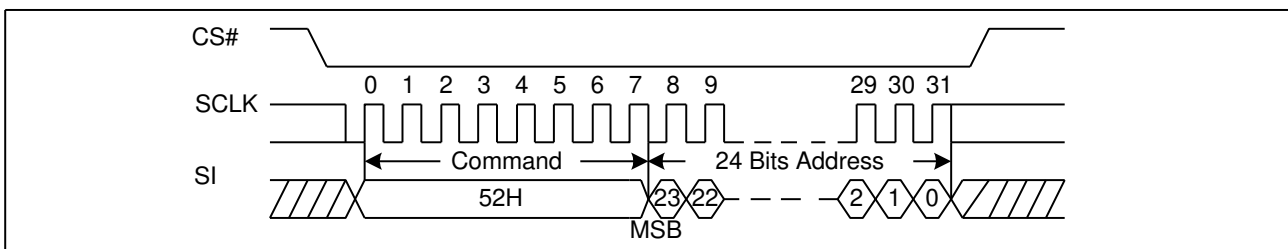

### 7.11. 64KB Block Erase (BE) (D8H)

The 64KB Block Erase (BE) command is for erasing the all data of the chosen block. A Write Enable (WREN) command must previously have been executed to set the Write Enable Latch (WEL) bit. The 64KB Block Erase (BE) command is entered by driving CS# low, followed by the command code, and three address bytes on SI. Any address inside the block is a valid address for the 64KB Block Erase (BE) command. CS# must be driven low for the entire duration of the sequence.

The 64KB Block Erase command sequence: CS# goes low → sending 64KB Block Erase command → 3-byte address on SI → CS# goes high. The command sequence is shown in Figure11. CS# must be driven high after the eighth bit of the last address byte has been latched in; otherwise the 64KB Block Erase (BE) command is not executed. As soon as CS# is driven high, the self-timed Block Erase cycle (whose duration is  $t_{BE}$ ) is initiated. While the Block Erase cycle is in progress, the Status Register is accessed to check the value of the Write In Progress (WIP) bit. The Write In Progress (WIP) bit is 1 during the self-timed Block Erase cycle, and becomes 0 when it is completed. At some unspecified time before the cycle is completed, the Write Enable Latch (WEL) bit is reset. A 64KB Block Erase (BE) command applied to a block which is protected by the Block Protect (BP2, BP1, BP0) bits (see Table1) is not executed.

**Figure11. 64KB Block Erase Sequence Diagram**

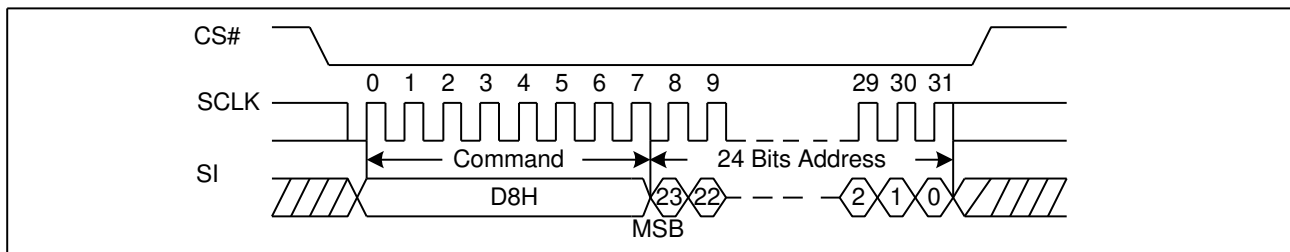

### 7.12. Chip Erase (CE) (60/C7H)

The Chip Erase (CE) command is for erasing the all data of the chip. A Write Enable (WREN) command must previously have been executed to set the Write Enable Latch (WEL) bit. The Chip Erase (CE) command is entered by driving CS# Low, followed by the command code on Serial Data Input (SI). CS# must be driven Low for the entire duration of the sequence.

The Chip Erase command sequence: CS# goes low → sending Chip Erase command → CS# goes high. The command sequence is shown in Figure12. CS# must be driven high after the eighth bit of the command code has been latched in, otherwise the Chip Erase command is not executed. As soon as CS# is driven high, the self-timed Chip Erase cycle (whose duration is  $t_{CE}$ ) is initiated. While the Chip Erase cycle is in progress, the Status Register may be read to check the value of the Write In Progress (WIP) bit. The Write In Progress (WIP) bit is 1 during the self-timed Chip Erase cycle, and is 0 when it is completed. At some unspecified time before the cycle is completed, the Write Enable Latch (WEL) bit is reset. The Chip Erase (CE) command is executed if the Block Protect (BP2, BP1, BP0) bits are all 0. The Chip Erase (CE) command is not executed if any sector is under protection.

**Figure12. Chip Erase Sequence Diagram**

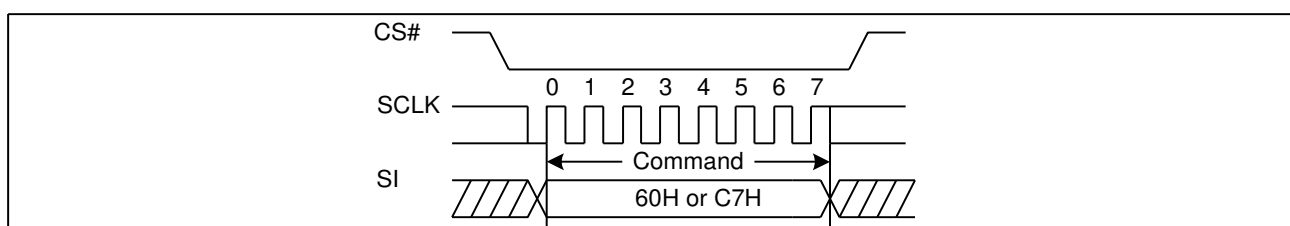

### 7.13. Deep Power-Down (DP) (B9H)

Executing the Deep Power-Down (DP) command is the only way to enter the lowest consumption mode (the Deep Power-Down Mode). Unlike deselecting the device by driving CS# high, or entering into the Standby Mode (if there is no internal cycle currently in progress), the Deep Power-Down Mode provides an extra software protection mechanism while the device is not in active use. The only access to this mode is by executing the Deep Power-Down (DP) command. Since in the Deep Power-Down mode, the device ignores all Write, Program and Erase commands. Once the device is in the Deep Power-Down Mode, all commands are ignored except the Release from Deep Power-Down and Read Device ID (RDI) command. This releases the device from this mode. The Release from Deep Power-Down and Read Device ID (RDI) command also allows the Device ID of the device to be output on SO.

The Deep Power-Down Mode automatically stops at Power-Down, and the device always Power-Up in the Standby Mode. The Deep Power-Down (DP) command is entered by driving CS# low, followed by the command code on SI. CS# must be driven low for the entire duration of the sequence.

The Deep Power-Down command sequence: CS# goes low → sending Deep Power-Down command → CS# goes high. The command sequence is shown in Figure13. CS# must be driven high after the eighth bit of the command code has been latched in; otherwise the Deep Power-Down (DP) command is not executed. As soon as CS# is driven high, it requires a delay of  $t_{DP}$  before the supply current is reduced to  $I_{CC2}$  and the Deep Power-Down Mode is entered. Any Deep Power-Down (DP) command, while an Erase, Program or Write cycle is in progress, is rejected without having any effects on the cycle that is in progress.

**Figure13. Deep Power-Down Sequence Diagram**

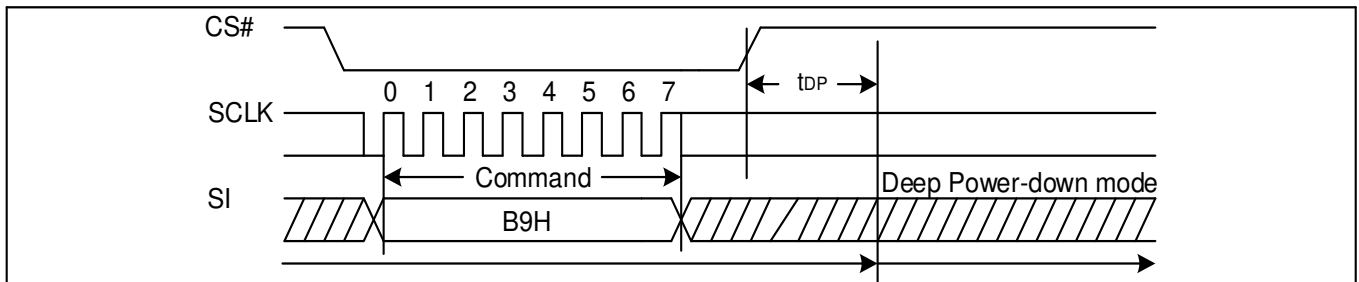

**7.14. Release from Deep Power-Down / Read Device ID (ABH)**

The Release from Power-Down and Read Device ID command is a multi-purpose command, which can be used to release the device from the Power-Down state or obtain the devices electronic identification (ID) number.

When used to release the device from the Power-Down state, the command is issued by driving the CS# pin low, shifting the instruction code “ABH” and driving CS# high as shown in Figure14. Release from Power-Down will take the time duration of  $t_{RES1}$  (See AC Characteristics) before the device will resume normal operation and other command are accepted. The CS# pin must keep high during the  $t_{RES1}$  time duration.

When used only to obtain the Device ID while not in the Power-Down state, the command is initiated by driving the CS# pin low and shifting the instruction code “ABH” followed by 3-dummy byte. The Device ID bits are then shifted out on the falling edge of SCLK with most significant bit (MSB) first as shown in Figure15. The Device ID value for the GD25D80C is listed in Manufacturer and Device Identification table. The Device ID can be read continuously. The command is completed by driving CS# high.

When used to release the device from the Power-Down state and obtain the Device ID, the command is the same as previously described, and shown in Figure15, except that after CS# is driven high it must remain high for a time duration of  $t_{RES2}$  (See AC Characteristics). After this time duration the device will resume normal operation and other command will be accepted. If the Release from Power-Down and Read Device ID command is issued while an Erase, Program or Write cycle is in process (when WIP equal 1) the command is ignored and will not have any effects on the current cycle.

**Figure14. Release Power-Down Sequence Diagram**

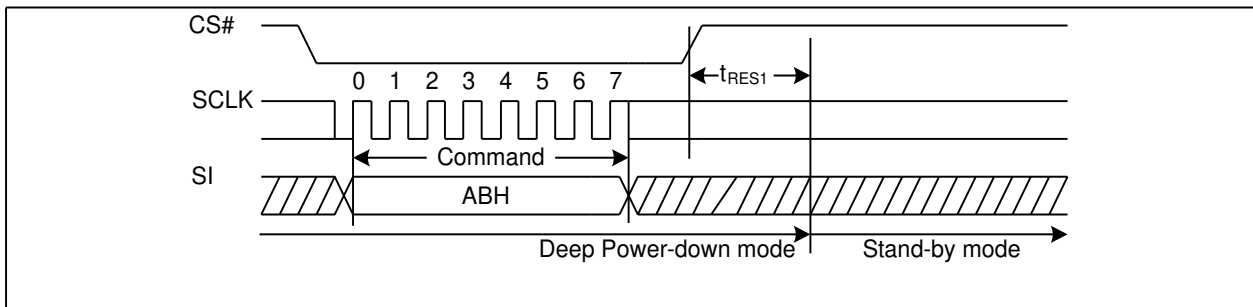

**Figure15. Release Power-Down and Read Device ID Sequence Diagram**

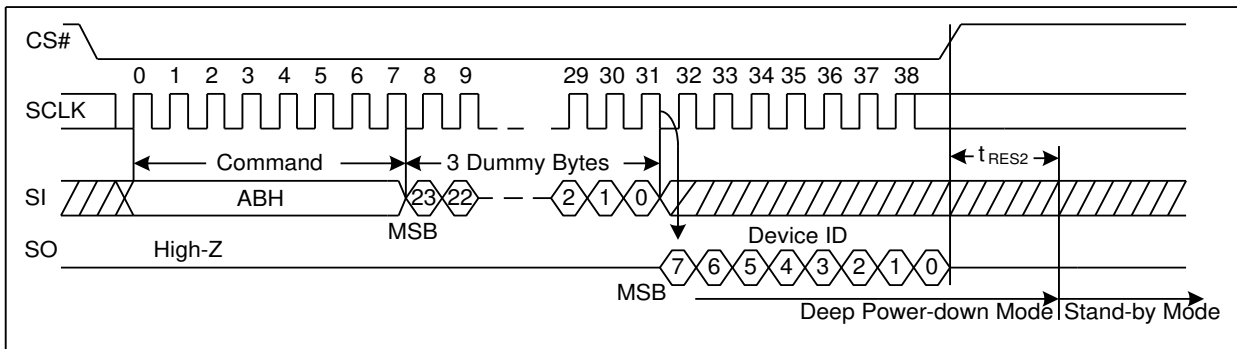

**7.15. Read Manufacture ID/ Device ID (REMS) (90H)**

The Read Manufacturer/Device ID command is an alternative to the Release from Power-Down / Device ID command that provides both the JEDEC assigned Manufacturer ID and the specific Device ID.

The command is initiated by driving the CS# pin low and shifting the command code “90H” followed by a 24-bit address (A23-A0) of 000000H. After that, the Manufacturer ID and the Device ID are shifted out on the falling edge of SCLK with most significant bit (MSB) first as shown in Figure16.

**Figure16. Read Manufacture ID/ Device ID Sequence Diagram**

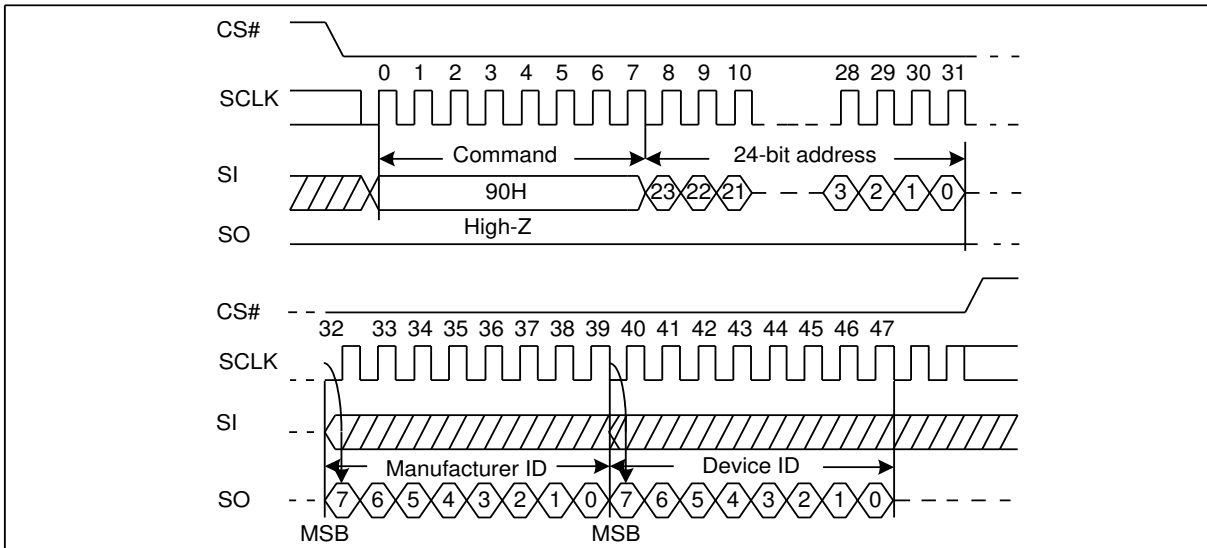

### 7.16. Read Identification (RDID) (9FH)

The Read Identification (RDID) command allows the 8-bit manufacturer identification to be read, followed by two bytes of device identification. The device identification indicates the memory type in the first byte, and the memory capacity of the device in the second byte. Any Read Identification (RDID) command while an Erase or Program cycle is in progress is not decoded, and has no effect on the cycle that is in progress. The Read Identification (RDID) command should not be issued while the device is in Deep Power-Down Mode.

The device is first selected by driving CS# low. Then, the 8-bit command code for the command is shifted in. This is followed by the 24-bit device identification, stored in the memory. Each bit is shifted out on the falling edge of Serial Clock. The command sequence is shown in Figure17. The Read Identification (RDID) command is terminated by driving CS# high at any time during data output. When CS# is driven high, the device is in the Standby Mode. Once in the Standby Mode, the device waits to be selected, so that it can receive, decode and execute commands.

**Figure17. Read Identification ID Sequence Diagram**

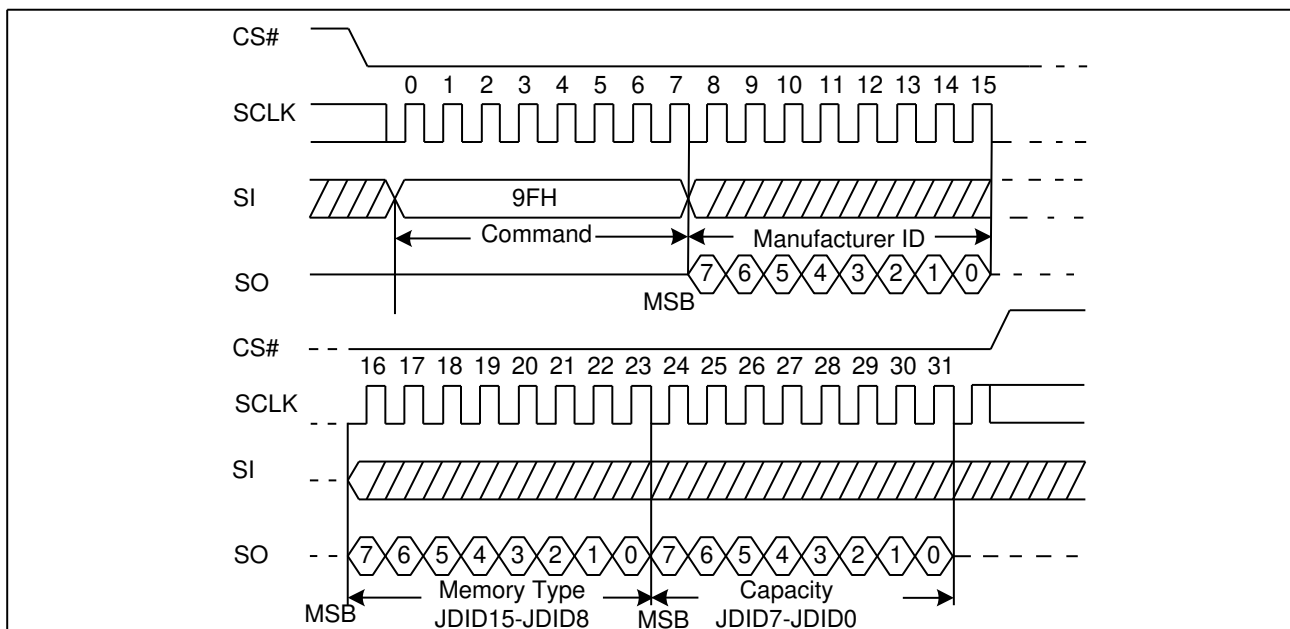

**7.17. Read Unique ID (4BH)**

The Read Unique ID command accesses a factory-set read-only 128bit number that is unique to each device. The Unique ID can be used in conjunction with user software methods to help prevent copying or cloning of a system.

The Read Unique ID command sequence: CS# goes low → sending Read Unique ID command → 3-Byte Address (000000H) → Dummy Byte → 128bit Unique ID Out → CS# goes high.

**Figure18. Read Unique ID Sequence Diagram**

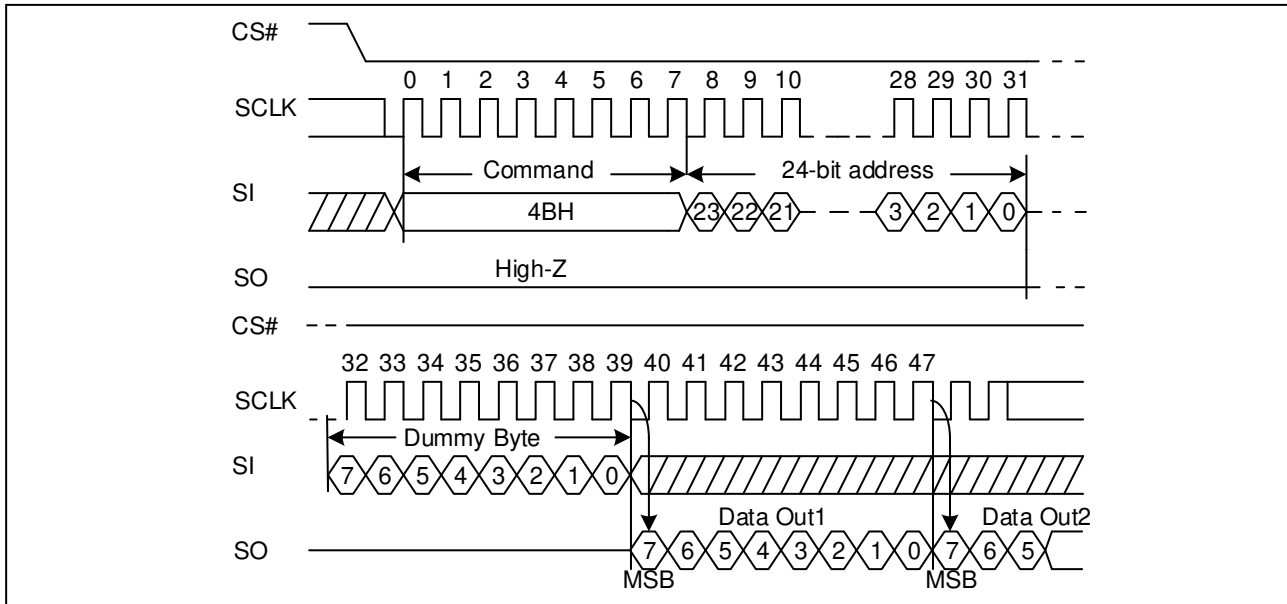



## 8. ELECTRICAL CHARACTERISTICS

### 8.1. POWER-ON TIMING

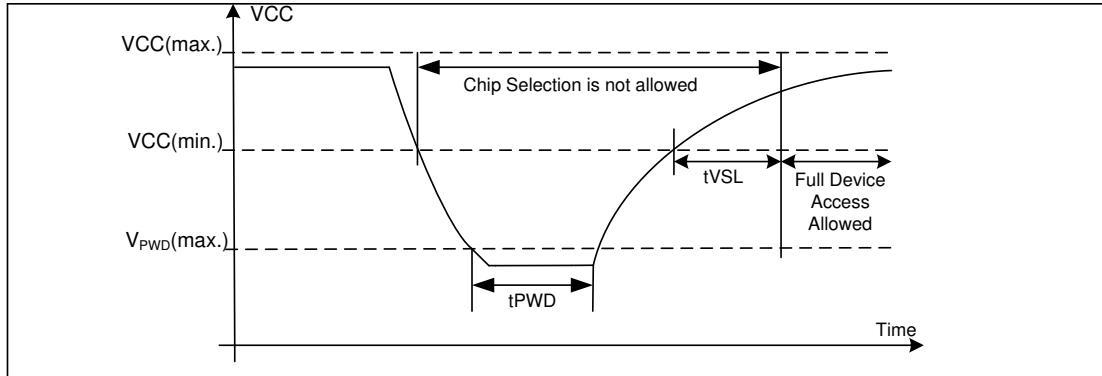

**Table3. Power-Up Timing and Write Inhibit Threshold**

Symbol	Parameter	Min.	Max.	Unit
tVSL	VCC (min.) to device operation	0.3		ms
VWI	Write Inhibit Voltage	1.5	2.5	V
VPWD	VCC voltage needed to below VPWD for ensuring initialization will occur		0.5	V
tPVD	The minimum duration for ensuring initialization will occur	300		us

### 8.2. INITIAL DELIVERY STATE

The device is delivered with the memory array erased: all bits are set to 1 (each byte contains FFH). The Status Register contains 00H (all Status Register bits are 0).

### 8.3. ABSOLUTE MAXIMUM RATINGS

Parameter	Value	Unit
Ambient Operating Temperature	-40 to 85 -40 to 105 -40 to 125	°C
Storage Temperature	-65 to 150	°C
Applied Input/Output Voltage	-0.6 to VCC+0.4	V
Transient Input/Output Voltage ( <b>note</b> : overshoot)	-2.0 to VCC+2.0	V
VCC	-0.6 to 4.2	V

**Figure19. Maximum Negative/positive Overshoot Diagram**

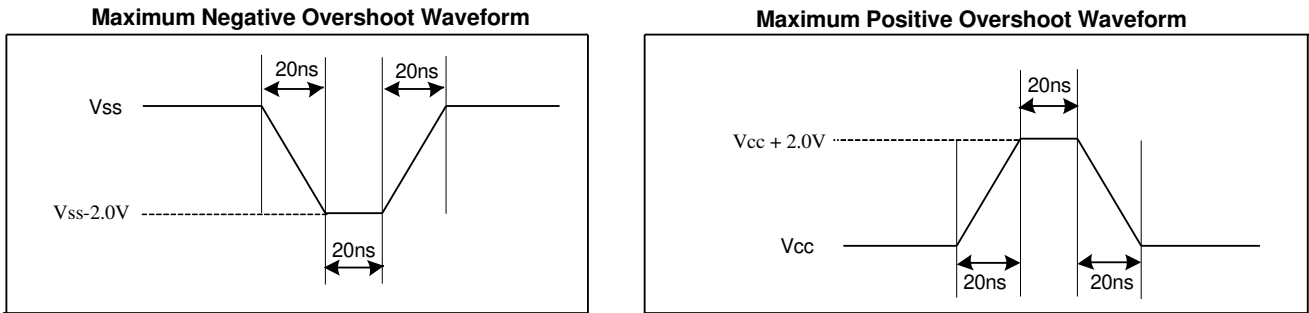

**8.4. CAPACITANCE MEASUREMENT CONDITIONS**

Symbol	Parameter	Min	Typ	Max	Unit	Conditions
CIN	Input Capacitance			6	pF	VIN=0V
COUT	Output Capacitance			8	pF	VOUT=0V
CL	Load Capacitance	30			pF	
	Input Rise And Fall time			5	ns	
	Input Pulse Voltage	0.1VCC to 0.8VCC			V	
	Input Timing Reference Voltage	0.2VCC to 0.7VCC			V	
	Output Timing Reference Voltage	0.5VCC			V	

**Figure 20. Input Test Waveform and Measurement Level**

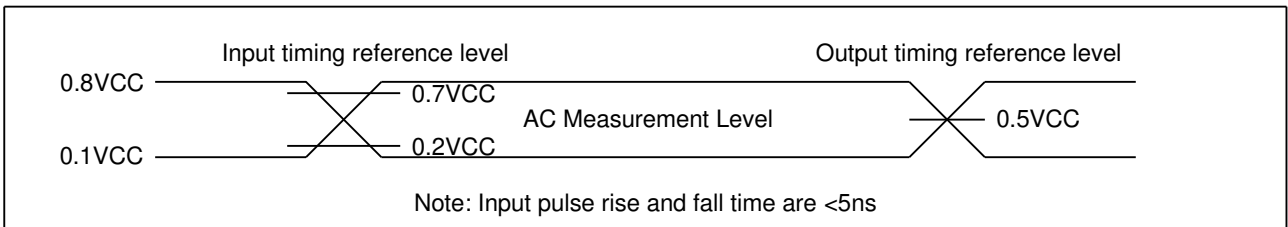

## 8.5. DC CHARACTERISTICS

(T= -40°C~85°C, VCC=2.7~3.6V)

Symbol	Parameter	Test Condition	Min.	Typ.	Max.	Unit.
I <sub>LI</sub>	Input Leakage Current				±2	μA
I <sub>LO</sub>	Output Leakage Current				±2	μA
I <sub>CC1</sub>	Standby Current	CS#=VCC, V <sub>IN</sub> =VCC or VSS		0.1	2	μA
I <sub>CC2</sub>	Deep Power-Down Current	CS#=VCC, V <sub>IN</sub> =VCC or VSS		0.1	2	μA
I <sub>CC3</sub>	Operating Current (Read)	CLK=0.1VCC / 0.9VCC At 100MHz, Q=Open(*1 I/O)		3	6	mA
		CLK=0.1VCC / 0.9VCC at 80MHz, Q=Open(*1 I/O,*2 Output)		2.5	4.5	mA
		CLK=0.1VCC / 0.9VCC At 50MHz, Q=Open(*1 I/O)		2	3.5	mA
I <sub>CC4</sub>	Operating Current (PP)	CS#=VCC			20	mA
I <sub>CC5</sub>	Operating Current (WRSR)	CS#=VCC			20	mA
I <sub>CC6</sub>	Operating Current (SE)	CS#=VCC			20	mA
I <sub>CC7</sub>	Operating Current (BE)	CS#=VCC			20	mA
I <sub>CC8</sub>	Operating Current (CE)	CS#=VCC			20	mA
V <sub>IL</sub>	Input Low Voltage		-0.5		0.2VCC	V
V <sub>IH</sub>	Input High Voltage		0.7VCC		VCC+0.4	V
V <sub>OL</sub>	Output Low Voltage	I <sub>OL</sub> =100μA			0.4	V
V <sub>OH</sub>	Output High Voltage	I <sub>OH</sub> =-100μA	VCC-0.2			V

Note:

1. Typical values given for TA=25°C VCC = 1.8V.
2. Value guaranteed by design and/or characterization, not 100% tested in production.

(T= -40°C~105°C, VCC=2.7~3.6V)

Symbol	Parameter	Test Condition	Min.	Typ	Max.	Unit.
I <sub>LI</sub>	Input Leakage Current				±2	μA
I <sub>LO</sub>	Output Leakage Current				±2	μA
I <sub>CC1</sub>	Standby Current	CS#=VCC, V <sub>IN</sub> =VCC or VSS		0.1	10	μA
I <sub>CC2</sub>	Deep Power-Down Current	CS#=VCC, V <sub>IN</sub> =VCC or VSS		0.1	10	μA
I <sub>CC3</sub>	Operating Current (Read)	CLK=0.1VCC / 0.9VCC At 100MHz, Q=Open(*1 I/O)		3	22	mA
		CLK=0.1VCC / 0.9VCC at 80MHz, Q=Open(*1 I/O,*2 Output)		2.5	20	mA
I <sub>CC4</sub>	Operating Current (PP)	CS#=VCC			30	mA
I <sub>CC5</sub>	Operating Current (WRSR)	CS#=VCC			30	mA
I <sub>CC6</sub>	Operating Current (SE)	CS#=VCC			30	mA
I <sub>CC7</sub>	Operating Current (BE)	CS#=VCC			30	mA
I <sub>CC8</sub>	Operating Current (CE)	CS#=VCC			30	mA
V <sub>IL</sub>	Input Low Voltage		-0.5		0.2VCC	V
V <sub>IH</sub>	Input High Voltage		0.7VCC		VCC+0.4	V
V <sub>OL</sub>	Output Low Voltage	I <sub>OL</sub> =100μA			0.4	V
V <sub>OH</sub>	Output High Voltage	I <sub>OH</sub> =-100μA	VCC-0.2			V

Note:

1. Typical values given for TA=25°C VCC = 1.8V.
2. Value guaranteed by design and/or characterization, not 100% tested in production.

(T= -40°C~125°C, VCC=2.7~3.6V)

Symbol	Parameter	Test Condition	Min.	Typ	Max.	Unit.
I <sub>LI</sub>	Input Leakage Current				±2	μA
I <sub>LO</sub>	Output Leakage Current				±2	μA
I <sub>CC1</sub>	Standby Current	CS#=VCC, V <sub>IN</sub> =VCC or VSS		0.1	15	μA
I <sub>CC2</sub>	Deep Power-Down Current	CS#=VCC, V <sub>IN</sub> =VCC or VSS		0.1	15	μA
I <sub>CC3</sub>	Operating Current (Read)	CLK=0.1VCC / 0.9VCC At 100MHz, Q=Open(*1 I/O)		3	22	mA
		CLK=0.1VCC / 0.9VCC at 80MHz, Q=Open(*1 I/O,*2 Output)		2.5	20	mA
I <sub>CC4</sub>	Operating Current (PP)	CS#=VCC			30	mA
I <sub>CC5</sub>	Operating Current (WRSR)	CS#=VCC			30	mA
I <sub>CC6</sub>	Operating Current (SE)	CS#=VCC			30	mA
I <sub>CC7</sub>	Operating Current (BE)	CS#=VCC			30	mA
I <sub>CC8</sub>	Operating Current (CE)	CS#=VCC			30	mA
V <sub>IL</sub>	Input Low Voltage		-0.5		0.2VCC	V
V <sub>IH</sub>	Input High Voltage		0.7VCC		VCC+0.4	V
V <sub>OL</sub>	Output Low Voltage	I <sub>OL</sub> =100μA			0.4	V
V <sub>OH</sub>	Output High Voltage	I <sub>OH</sub> =-100μA	VCC-0.2			V

Note:

1. Typical values given for TA=25°C VCC = 1.8V.
2. Value guaranteed by design and/or characterization, not 100% tested in production.

## 8.6. AC CHARACTERISTICS

(T= -40°C~85°C, VCC=2.7~3.6V, CL=30pf)

Symbol	Parameter	Min.	Typ.	Max.	Unit
f <sub>C</sub>	Serial Clock Frequency For: Fast read (0BH)			100	MHz
f <sub>R</sub>	Serial Clock Frequency For: Read (03H), Dual Output (3BH)			80	MHz
t <sub>CLH</sub>	Serial Clock High Time	4			ns
t <sub>CLL</sub>	Serial Clock Low Time	4			ns
t <sub>CLCH</sub>	Serial Clock Rise Time (Slew Rate)	0.1			V/ns
t <sub>CHCL</sub>	Serial Clock Fall Time (Slew Rate)	0.1			V/ns
t <sub>SLCH</sub>	CS# Active Setup Time	5			ns
t <sub>CHSH</sub>	CS# Active Hold Time	5			ns
t <sub>SHCH</sub>	CS# Not Active Setup Time	5			ns
t <sub>CHSL</sub>	CS# Not Active Hold Time	5			ns
t <sub>SHSL</sub>	CS# High Time (Read/Write)	20			ns
t <sub>SHQZ</sub>	Output Disable Time			6	ns
t <sub>CLQX</sub>	Output Hold Time	0			ns
t <sub>DVCH</sub>	Data In Setup Time	2			ns
t <sub>CHDX</sub>	Data In Hold Time	2			ns
t <sub>CLQV</sub>	Clock Low To Output Valid			6	ns
t <sub>WHSL</sub>	Write Protect Setup Time Before CS# Low	20			ns
t <sub>SHWL</sub>	Write Protect Hold Time After CS# High	100			ns
t <sub>DP</sub>	CS# High To Deep Power-Down Mode			0.1	μs
t <sub>RES1</sub>	CS# High To Standby Mode Without Electronic Signature Read			0.1	μs
t <sub>RES2</sub>	CS# High To Standby Mode With Electronic Signature Read			0.1	μs
t <sub>W</sub>	Write Status Register Cycle Time		4	30	ms
t <sub>BP1</sub>	Byte Program Time (First Byte)		30	50	μs
t <sub>BP2</sub>	Addition Byte Program Time (After First Byte)		2.5	12	μs
t <sub>PP</sub>	Page Programming Time		0.7	4.0	ms
t <sub>SE</sub>	Sector Erase Time		100	400	ms
t <sub>BE1</sub>	Block Erase Time (32K Bytes)		0.3	1.2	s
t <sub>BE2</sub>	Block Erase Time (64K Bytes)		0.5	2.0	s
t <sub>CE</sub>	Chip Erase Time (GD25D80C)		8	16	s

Note:

1. Typical values given for TA=25°C VCC = 1.8V.
2. Value guaranteed by design and/or characterization, not 100% tested in production.

(T= -40°C~105°C, VCC=2.7~3.6V, CL=30pf)

Symbol	Parameter	Min.	Typ.	Max.	Unit
f <sub>C</sub>	Serial Clock Frequency For: Fast read (0B)			100	MHz
f <sub>R</sub>	Serial Clock Frequency For: Read (03H) ,Dual Output (3BH)			80	MHz
t <sub>CLH</sub>	Serial Clock High Time	4			ns
t <sub>CLL</sub>	Serial Clock Low Time	4			ns
t <sub>CLCH</sub>	Serial Clock Rise Time (Slew Rate)	0.1			V/ns
t <sub>CHCL</sub>	Serial Clock Fall Time (Slew Rate)	0.1			V/ns
t <sub>SLCH</sub>	CS# Active Setup Time	5			ns
t <sub>CHSH</sub>	CS# Active Hold Time	5			ns
t <sub>SHCH</sub>	CS# Not Active Setup Time	5			ns
t <sub>CHSL</sub>	CS# Not Active Hold Time	5			ns
t <sub>SHSL</sub>	CS# High Time (Read/Write)	40			ns
t <sub>SHQZ</sub>	Output Disable Time			6	ns
t <sub>CLQX</sub>	Output Hold Time	0			ns
t <sub>DVCH</sub>	Data In Setup Time	2			ns
t <sub>CHDX</sub>	Data In Hold Time	2			ns
t <sub>CLQV</sub>	Clock Low To Output Valid			6	ns
t <sub>WHSL</sub>	Write Protect Setup Time Before CS# Low	20			ns
t <sub>SHWL</sub>	Write Protect Hold Time After CS# High	100			ns
t <sub>DP</sub>	CS# High To Deep Power-Down Mode			0.1	μs
t <sub>RES1</sub>	CS# High To Standby Mode Without Electronic Signature Read			0.1	μs
t <sub>RES2</sub>	CS# High To Standby Mode With Electronic Signature Read			0.1	μs
t <sub>W</sub>	Write Status Register Cycle Time		4	30	ms
t <sub>BP1</sub>	Byte Program Time(First Byte)		30	60	μs
t <sub>BP2</sub>	Addition Byte Program Time(After First Byte)		2.5	15	μs
t <sub>PP</sub>	Page Programming Time		0.7	4.0	ms
t <sub>SE</sub>	Sector Erase Time		100	400	ms
t <sub>BE1</sub>	Block Erase Time (32K Bytes)		0.3	1.2	s
t <sub>BE2</sub>	Block Erase Time (64K Bytes)		0.5	2.0	s
t <sub>CE</sub>	Chip Erase Time (GD25D80C)		8	20	s

Note:

1. Typical values given for TA=25°C VCC = 1.8V.
2. Value guaranteed by design and/or characterization, not 100% tested in production.

(T= -40°C~125°C, VCC=2.7~3.6V, CL=30pf)

Symbol	Parameter	Min.	Typ.	Max.	Unit
f <sub>C</sub>	Serial Clock Frequency For: Fast read (0B)			100	MHz
f <sub>R</sub>	Serial Clock Frequency For: Read (03H) ,Dual Output (3BH)			80	MHz
t <sub>CLH</sub>	Serial Clock High Time	4			ns
t <sub>CLL</sub>	Serial Clock Low Time	4			ns
t <sub>CLCH</sub>	Serial Clock Rise Time (Slew Rate)	0.1			V/ns
t <sub>CHCL</sub>	Serial Clock Fall Time (Slew Rate)	0.1			V/ns
t <sub>SLCH</sub>	CS# Active Setup Time	5			ns
t <sub>CHSH</sub>	CS# Active Hold Time	5			ns
t <sub>SHCH</sub>	CS# Not Active Setup Time	5			ns
t <sub>CHSL</sub>	CS# Not Active Hold Time	5			ns
t <sub>SHSL</sub>	CS# High Time (Read/Write)	40			ns
t <sub>SHQZ</sub>	Output Disable Time			6	ns
t <sub>CLQX</sub>	Output Hold Time	0			ns
t <sub>DVCH</sub>	Data In Setup Time	2			ns
t <sub>CHDX</sub>	Data In Hold Time	2			ns
t <sub>CLQV</sub>	Clock Low To Output Valid			6	ns
t <sub>WHSL</sub>	Write Protect Setup Time Before CS# Low	20			ns
t <sub>SHWL</sub>	Write Protect Hold Time After CS# High	100			ns
t <sub>DP</sub>	CS# High To Deep Power-Down Mode			0.1	μs
t <sub>RES1</sub>	CS# High To Standby Mode Without Electronic Signature Read			0.1	μs
t <sub>RES2</sub>	CS# High To Standby Mode With Electronic Signature Read			0.1	μs
t <sub>W</sub>	Write Status Register Cycle Time		4	30	ms
t <sub>BP1</sub>	Byte Program Time(First Byte)		30	80	μs
t <sub>BP2</sub>	Addition Byte Program Time(After First Byte)		2.5	20	μs
t <sub>PP</sub>	Page Programming Time		0.7	4.0	ms
t <sub>SE</sub>	Sector Erase Time		100	400	ms
t <sub>BE1</sub>	Block Erase Time (32K Bytes)		0.3	1.2	s
t <sub>BE2</sub>	Block Erase Time (64K Bytes)		0.5	2.0	s
t <sub>CE</sub>	Chip Erase Time (GD25D80C)		8	20	s

Note:

1. Typical values given for TA=25°C VCC = 1.8V.
2. Value guaranteed by design and/or characterization, not 100% tested in production.



**Figure20. Serial Input Timing**

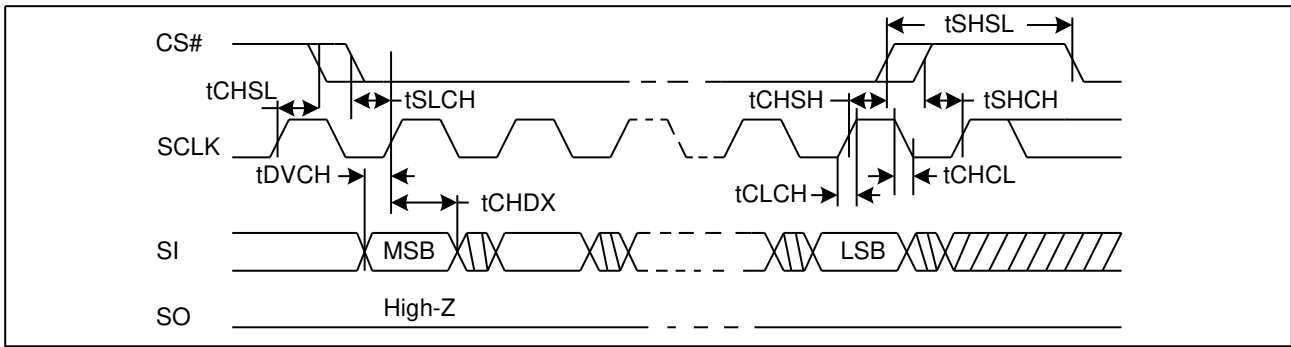

**Figure21. Output Timing**

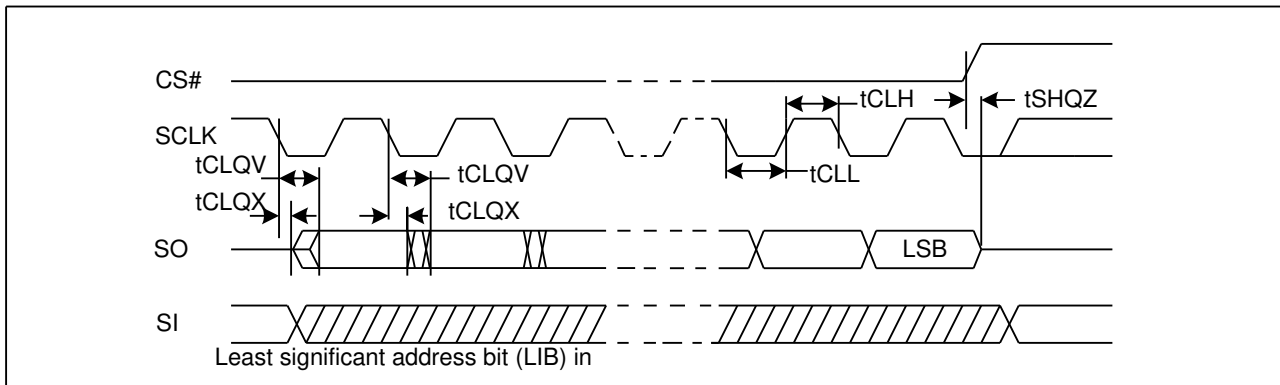

## 9. ORDERING INFORMATION

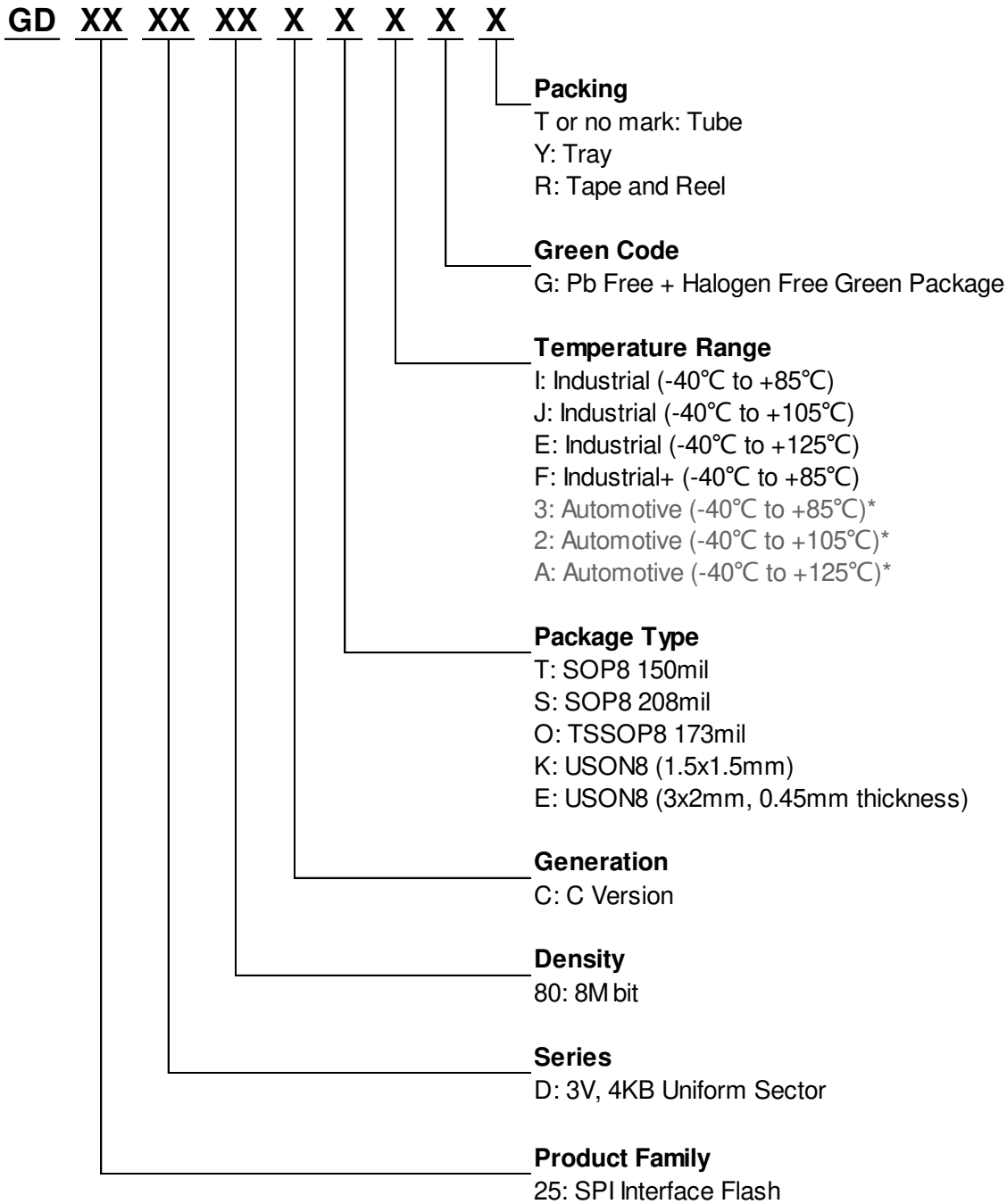

\*Please contact GigaDevice sales for automotive products.

**9.1. Valid Part Numbers**

Please contact GigaDevice regional sales for the latest product selection and available form factors.

**Temperature Range I: Industrial (-40°C to +85°C)**

Product Number	Density	Package Type
GD25D80CTIG	8Mbit	SOP8 150mil
GD25D80CSIG	8Mbit	SOP8 208mil
GD25D80COIG	8Mbit	TSSOP8 173mil
GD25D80CKIG	8Mbit	USON8 (1.5x1.5mm)
GD25D80CEIG	8Mbit	USON8 (3x2mm, 0.45mm thickness)

**Temperature Range J: Industrial (-40°C to +105°C)**

Product Number	Density	Package Type
GD25D80CTJG	8Mbit	SOP8 150mil
GD25D80CSJG	8Mbit	SOP8 208mil
GD25D80COJG	8Mbit	TSSOP8 173mil
GD25D80CKJG	8Mbit	USON8 (1.5x1.5mm)
GD25D80CEJG	8Mbit	USON8 (3x2mm, 0.45mm thickness)

**Temperature Range E: Industrial (-40°C to +125°C)**

Product Number	Density	Package Type
GD25D80CTEG	8Mbit	SOP8 150mil
GD25D80CSEG	8Mbit	SOP8 208mil
GD25D80COEG	8Mbit	TSSOP8 173mil
GD25D80CKEG	8Mbit	USON8 (1.5x1.5mm)
GD25D80CEEG	8Mbit	USON8 (3x2mm, 0.45mm thickness)

**Temperature Range F: Industrial+ (-40°C to +85°C)**

Product Number	Density	Package Type
GD25D80CTFG	8Mbit	SOP8 150mil
GD25D80CSFG	8Mbit	SOP8 208mil
GD25D80COFG	8Mbit	TSSOP8 173mil
GD25D80CKFG	8Mbit	USON8 (1.5x1.5mm)
GD25D80CEFG	8Mbit	USON8 (3x2mm, 0.45mm thickness)

## 10. PACKAGE INFORMATION

### 10.1. Package SOP8 150MIL

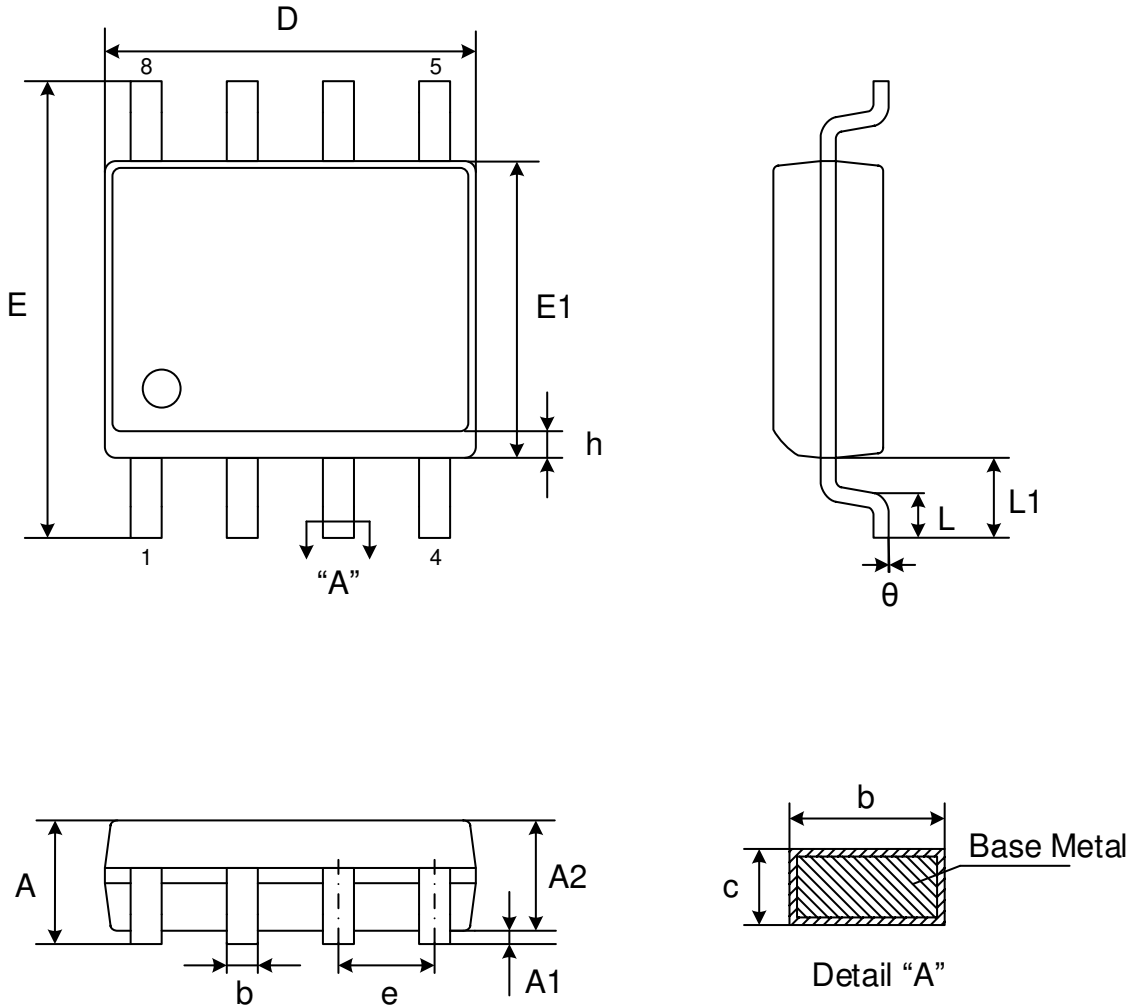

### Dimensions

Symbol		A	A1	A2	b	c	D	E	E1	e	L	L1	h	$\theta$
Unit														
mm	Min	-	0.10	1.25	0.31	0.10	4.80	5.80	3.80	1.27	0.40	1.04	0.25	0°
	Nom	-	0.15	1.45	0.41	0.20	4.90	6.00	3.90		-		-	-
	Max	1.75	0.25	1.55	0.51	0.25	5.00	6.20	4.00		0.90		0.50	8°

Note:

- Both the package length and width include the mold flash.
- Seating plane: Max. 0.1mm.

10.2. Package SOP8 208MIL

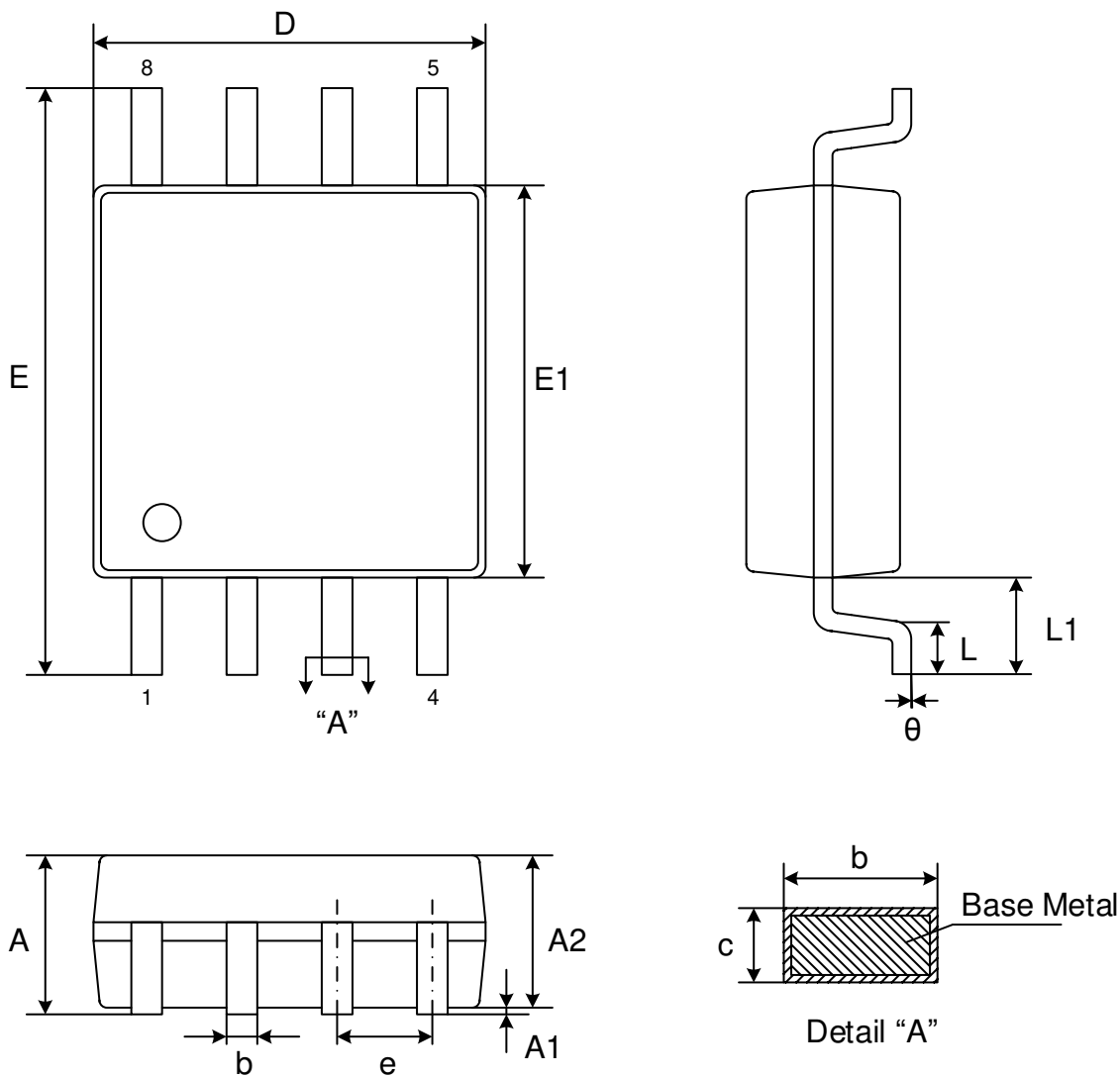

Dimensions

Symbol	A	A1	A2	b	c	D	E	E1	e	L	L1	θ	
Unit													
mm	Min	-	0.05	1.70	0.31	0.15	5.13	7.70	5.18	1.27	0.50	1.31	0°
	Nom	-	0.15	1.80	0.41	0.20	5.23	7.90	5.28		-		-
	Max	2.16	0.25	1.90	0.51	0.25	5.33	8.10	5.38		0.85		8°

Note:

- Both the package length and width do not include the mold flash.
- Seating plane: Max. 0.1mm.

10.3. Package TSSOP8 173MIL

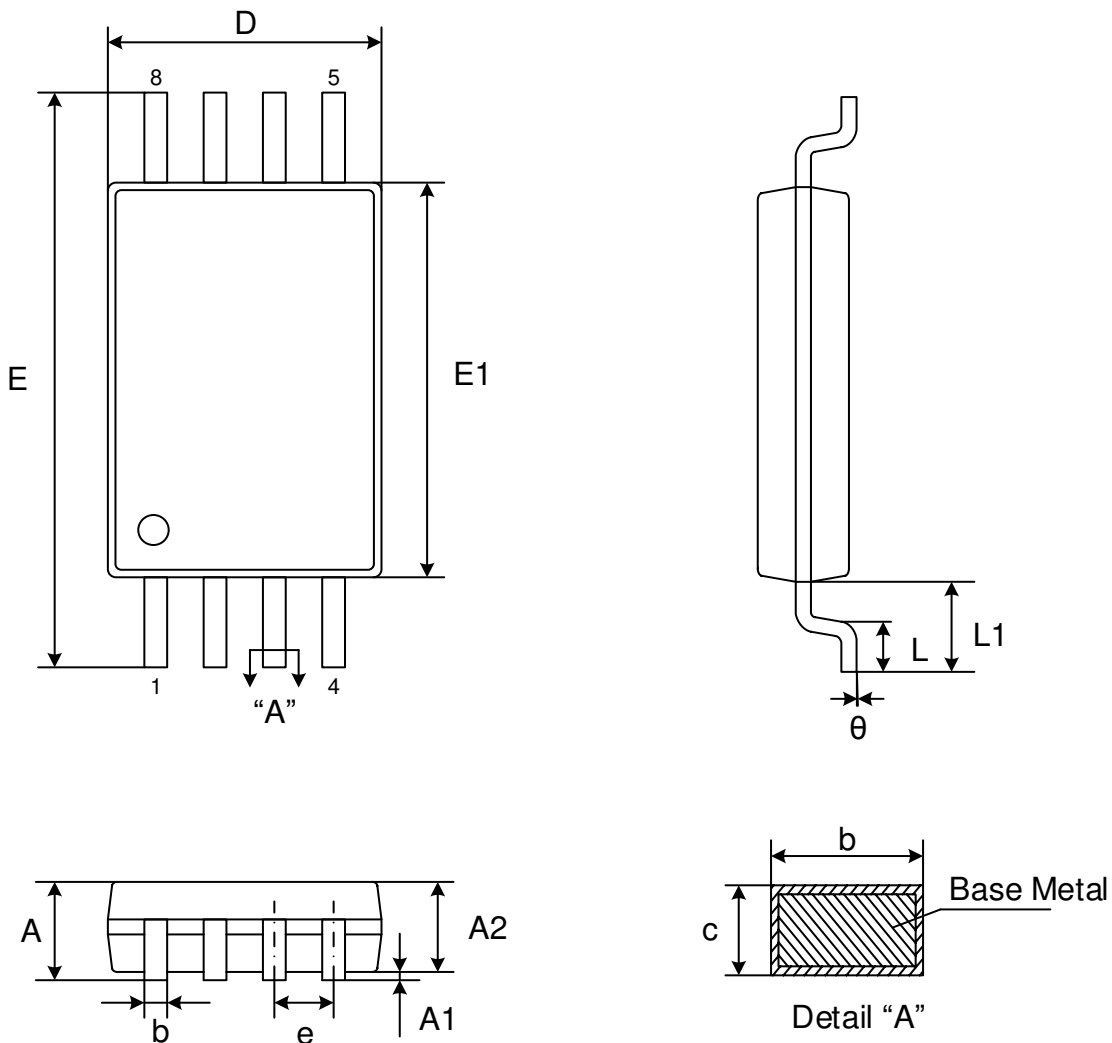

Dimensions

Symbol		A	A1	A2	b	c	D	E	E1	e	L	L1	$\theta$
Unit													
mm	Min	-	0.05	0.80	0.19	0.09	2.90	6.20	4.30	0.65	0.45	1.00	0°
	Nom	-	0.10	1.00	0.25	0.15	3.00	6.40	4.40		-		-
	Max	1.20	0.15	1.05	0.30	0.20	3.10	6.60	4.50		0.75		8°

Notes:

- Both package length and width do not include mold flash.
- Seating plane: Max. 0.1mm.

10.4. Package USON8 (1.5x1.5mm)

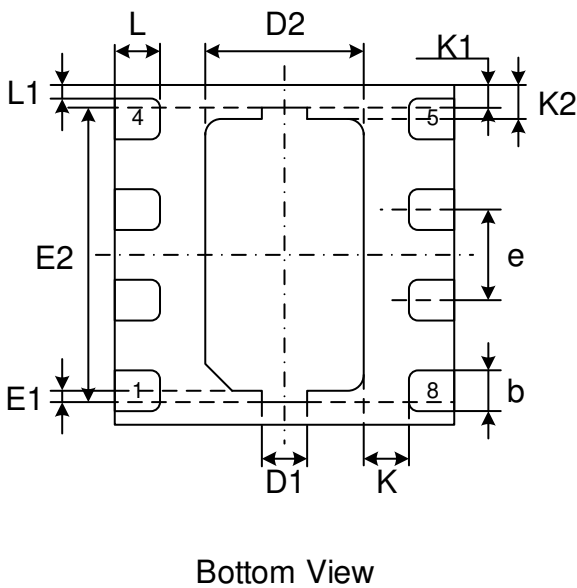
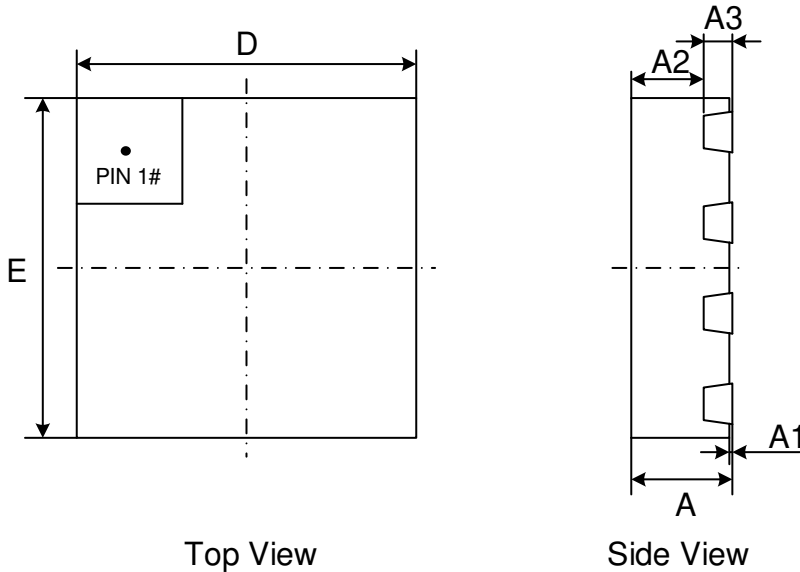

Dimensions

Symbol		A	A1	A2	A3	b	D	E	D1	E1	D2	E2	e	L	L1	K	K1	K2	
Unit																			
mm	Min	0.40	0.00	0.33	0.127	0.13	1.40	1.40	0.20	0.05	0.60	1.20	0.40	0.15	0.06	0.20	0.10	0.15	
	Nom	0.45	0.02			REF	REF	0.18			1.50	1.50		REF					REF
	Max	0.50	0.05			0.25	1.60	1.60			0.80	1.40		0.25					

Note:

- Both the package length and width do not include the mold flash.
- The exposed metal pad area on the bottom of the package is floating.
- Coplanarity  $\leq 0.08\text{mm}$ . Package edge tolerance  $\leq 0.10\text{mm}$ .
- The lead shape may be of little difference according to different package factories. These lead shapes are compatible with each other.

**10.5. Package USON8 (3x2mm, thickness 0.45mm)**

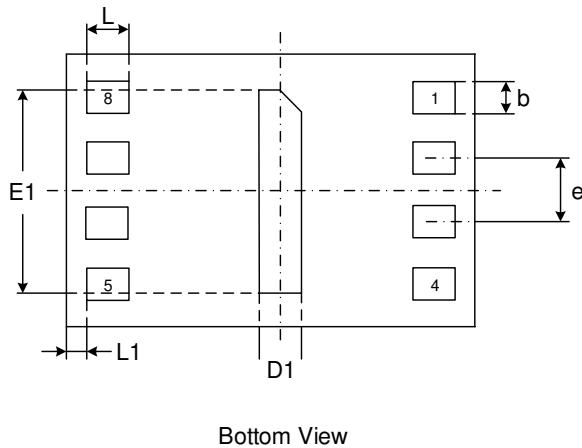
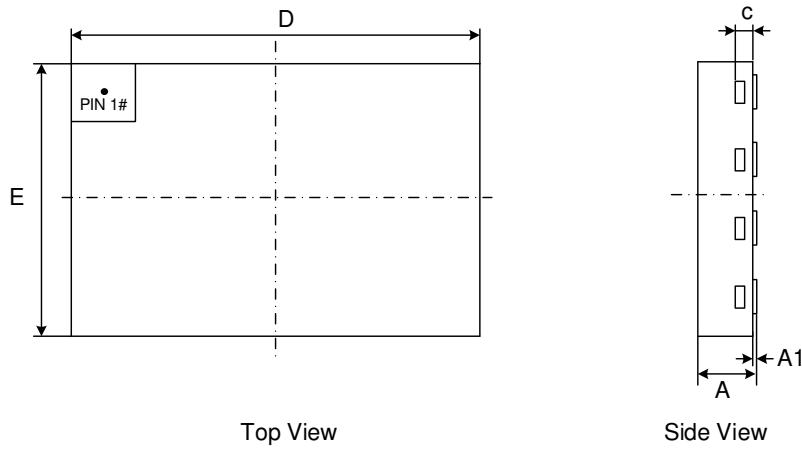

**Dimensions**

Symbol		A	A1	c	b	D	D1	E	E1	e	L	L1
Unit												
mm	Min	0.40	0.00	0.10	0.20	2.90	0.15	1.90	1.55	0.50	0.30	0.10
	Nom	0.45	0.02	0.15	0.25	3.00	0.20	2.00	1.60		0.35	
	Max	0.50	0.05	0.20	0.30	3.10	0.25	2.10	1.65		0.40	

Note:

- Both the package length and width do not include the mold flash.
- The exposed metal pad area on the bottom of the package is floating.
- Coplanarity  $\leq 0.08\text{mm}$ . Package edge tolerance  $\leq 0.10\text{mm}$ .
- The lead shape may be of little difference according to different package factories. These lead shapes are compatible with each other.



**11. REVISION HISTORY**

Version No	Description	Page	Date
1.0	Initial Release	All	2018-1-17
1.1	Modify tVSL min value from 5ms to 0.5ms Modify tBP1 from 15~30us to 30~50us Modify tBP2 from 2.5~5us to 2.5~12us Add "J" and "E" to 7th code of Ordering Information	P24 P27 P27 P29	2018-4-23
1.2	Modify tVSL min value from 0.5ms to 0.3ms Add package of USON8 1.5*1.5mm	P24 P29, 30, 35	2018-6-1
1.3	Add 4BH command Add DC/AC characteristics @-40°C~105°C Add DC/AC characteristics @-40°C~125°C Modify Ordering Information Modify Package USON8 1.5*1.5mm Dimensions	P11 P28/30 P29/31 P33 P40	2018-7-19
1.4	Modify I <sub>OL</sub> value from 1.6mA to 100μA Remove Package DIP8 300mil	P28/29 ---	2018-9-3
1.5	Modify I <sub>CC3</sub> typ. value @100MHz from 13mA to 3mA Modify I <sub>CC3</sub> typ. value @80MHz from 12mA to 2.5mA Modify I <sub>CC3</sub> max. value @100MHz @-40°C to 85°C from 18mA to 6mA Modify I <sub>CC3</sub> max. value @80MHz @-40°C to 85°C from 15mA to 4.5mA Add I <sub>CC3</sub> @50MHz @-40°C-85°C of 2~3.5mA	P27, 28, 29 P27, 28, 29 P27 P27 P27	2019-4-28

## Important Notice

This document is the property of GigaDevice Semiconductor (Beijing) Inc. and its subsidiaries (the "Company"). This document, including any product of the Company described in this document (the "Product"), is owned by the Company under the intellectual property laws and treaties of the People's Republic of China and other jurisdictions worldwide. The Company reserves all rights under such laws and treaties and does not grant any license under its patents, copyrights, trademarks, or other intellectual property rights. The names and brands of third party referred thereto (if any) are the property of their respective owner and referred to for identification purposes only.

The Company makes no warranty of any kind, express or implied, with regard to this document or any Product, including, but not limited to, the implied warranties of merchantability and fitness for a particular purpose. The Company does not assume any liability arising out of the application or use of any Product described in this document. Any information provided in this document is provided only for reference purposes. It is the responsibility of the user of this document to properly design, program, and test the functionality and safety of any application made of this information and any resulting product. Except for customized products which has been expressly identified in the applicable agreement, the Products are designed, developed, and/or manufactured for ordinary business, industrial, personal, and/or household applications only. The Products are not designed, intended, or authorized for use as components in systems designed or intended for the operation of weapons, weapons systems, nuclear installations, atomic energy control instruments, combustion control instruments, airplane or spaceship instruments, traffic signal instruments, life-support devices or systems, other medical devices or systems (including resuscitation equipment and surgical implants), pollution control or hazardous substances management, or other uses where the failure of the device or Product could cause personal injury, death, property or environmental damage ("Unintended Uses"). Customers shall take any and all actions to ensure using and selling the Products in accordance with the applicable laws and regulations. The Company is not liable, in whole or in part, and customers shall and hereby do release the Company as well as it's suppliers and/or distributors from any claim, damage, or other liability arising from or related to all Unintended Uses of the Products. Customers shall indemnify and hold the Company as well as it's suppliers and/or distributors harmless from and against all claims, costs, damages, and other liabilities, including claims for personal injury or death, arising from or related to any Unintended Uses of the Products. Customers shall discard the device according to the local environmental law.

**Information in this document is provided solely in connection with the Products. The Company reserves the right to make changes, corrections, modifications or improvements to this document and the Products and services described herein at any time, without notice.**