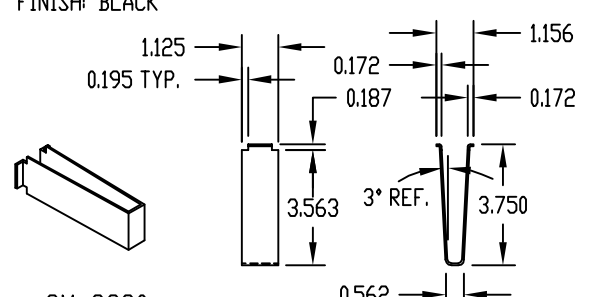
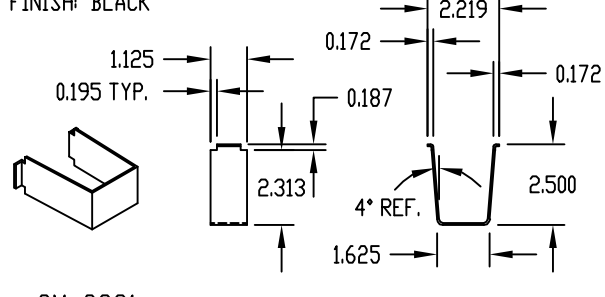
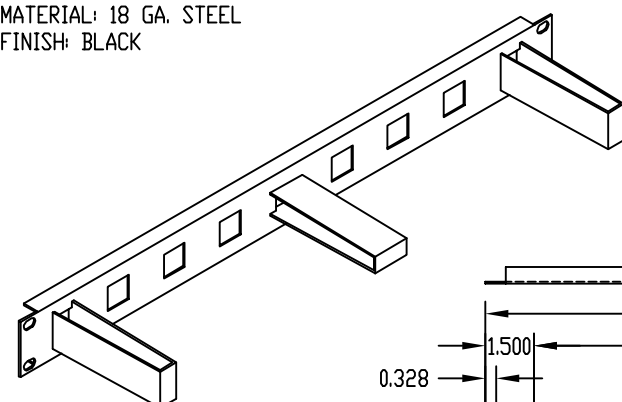
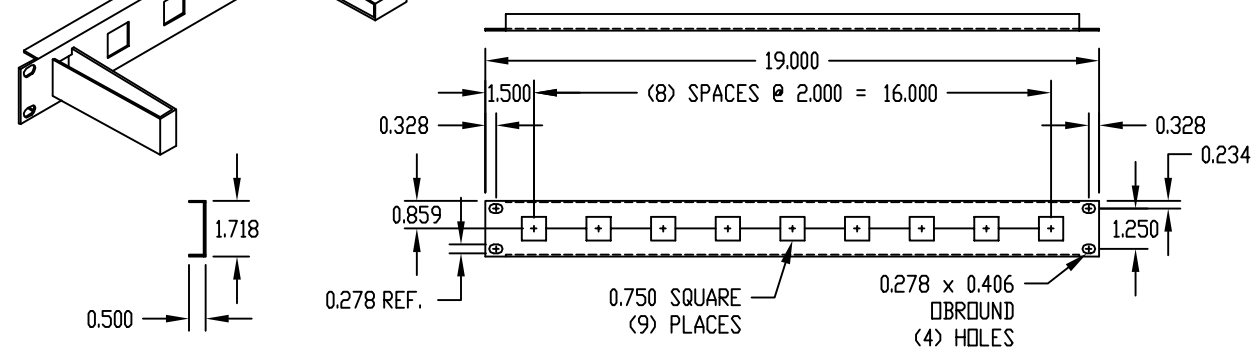
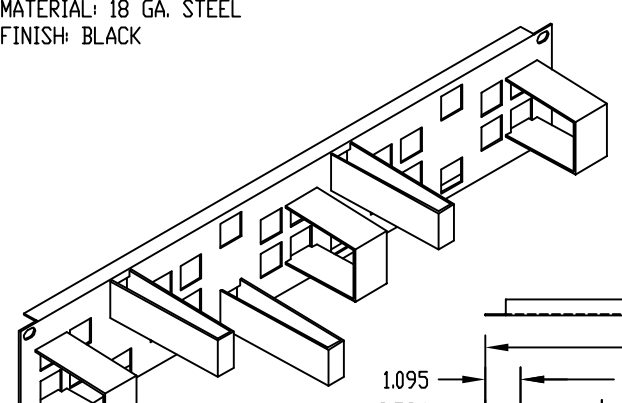

PART NAME	CABLE CLIP PACKAGE	PART No.	CM-2220 & CM-2221
MATERIAL: 16 GA. SPRING STEEL FINISH: BLACK  <b>CM-2220</b> SUPPLIED WITH (3) CABLE CLIP BRACKETS		MATERIAL: 16 GA. SPRING STEEL FINISH: BLACK  <b>CM-2221</b> SUPPLIED WITH (3) CABLE CLIP BRACKETS	

PART NAME	CABLE MANAGEMENT PANEL - 1U	PART No.	CM-2225
MATERIAL: 18 GA. STEEL FINISH: BLACK 		SUPPLIED WITH: QTY. (1) #CM-2220 CABLE CLIP PACKAGE QTY. (4) #10-32 x 5/8 LG. SCREWS QTY. (4) #12-24 x 1/2 LG. SCREWS 	

PART NAME	CABLE MANAGEMENT PANEL - 2U	PART No.	CM-2227
MATERIAL: 18 GA. STEEL FINISH: BLACK 		SUPPLIED WITH: QTY. (1) #CM-2220 CABLE CLIP PACKAGE QTY. (1) #CM-2221 CABLE CLIP PACKAGE QTY. (4) #10-32 x 5/8 LG. SCREWS QTY. (4) #12-24 x 1/2 LG. SCREWS 