

THIS DRAWING IS UNPUBLISHED. RELEASED FOR PUBLICATION
 © COPYRIGHT - By - ALL RIGHTS RESERVED.

LOC	DIST	REVISIONS					
AF	50	P	LTR	DESCRIPTION	DATE	DWN	APVD
		M		REVISED PER ECR-12-013459	28NOV2012	KH	PD

1 CONTINUOUS STRIP ON REELS.

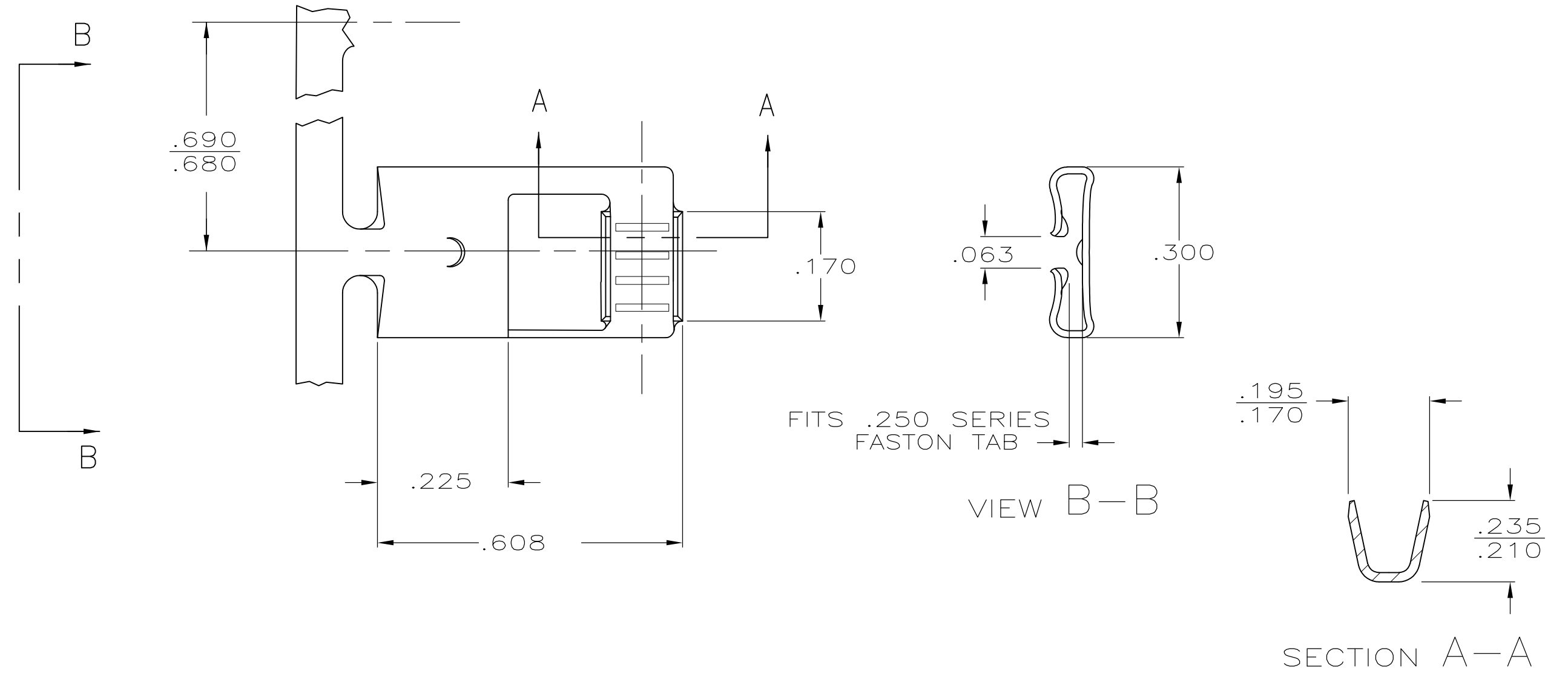

2 #14 STRANDED OR SOLID	.032	TIN	BRASS	60960-3
2 #12 STRANDED ONLY	.032		.018 BRASS	60960-2
12-10 STRANDED OR SOLID	.032	NICKEL	.018 STEEL	60960-1
WIRE SIZE	TAB THK ±.001	FINISH	MATERIAL	PART NO.

.220	F	.140	101	2 #14
			123	2 #12
			.111	10
			.093	12
STRIP LENGTH ±.015	TYPE	WIDTH	±.002 HEIGHT	WIRE
WIRE BARREL CRIMP				

THIS DRAWING IS A CONTROLLED DOCUMENT.

DIMENSIONS: INCHES

TOLERANCES UNLESS OTHERWISE SPECIFIED:

0 PLC	± -
1 PLC	± -
2 PLC	± -
3 PLC	± .015
4 PLC	± -
ANGLES	± -
MATERIAL	FINISH
-	-

DWN JR RUTH 10/9/85
 CHK G YETTER 10/9/85
 APVD C MEYERS 10/9/85

STE TE Connectivity

NAME .250 SERIES FLAG FASTON RECEPTACLE

PRODUCT SPEC -
 APPLICATION SPEC 114-2079
 WEIGHT -

SIZE A3 CAGE CODE 00779 DRAWING NO C-60960 RESTRICTED TO -

CUSTOMER DRAWING SCALE 4:1 SHEET 1 OF 1 REV M