

THIS DRAWING IS UNPUBLISHED. RELEASED FOR PUBLICATION JUN , 1996.
 © COPYRIGHT 1996 By - ALL RIGHTS RESERVED.

REVISIONS 變更					
P	LTR	DESCRIPTION	DATE	DWN	APVD
E		REVISED PER ECO-16-002717	5FEB2016	B.J.	S.Y.
E1		REVISED PER ECO-16-010364	18JUL2016	B.J	S.Y

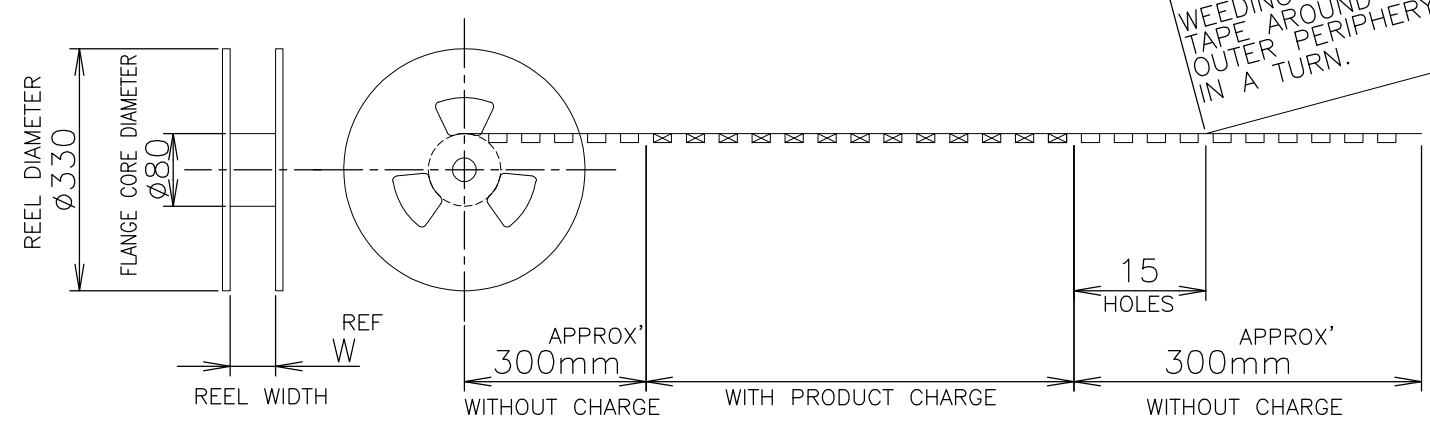
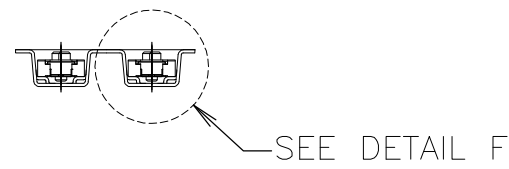
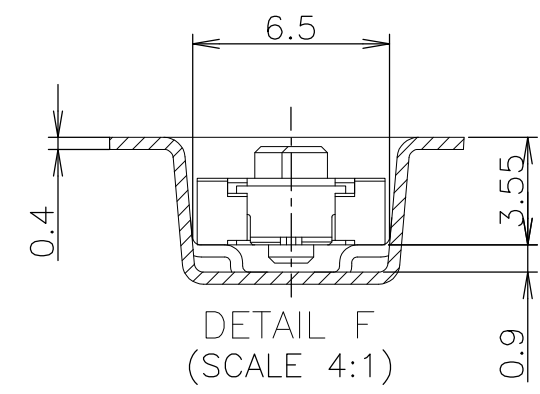
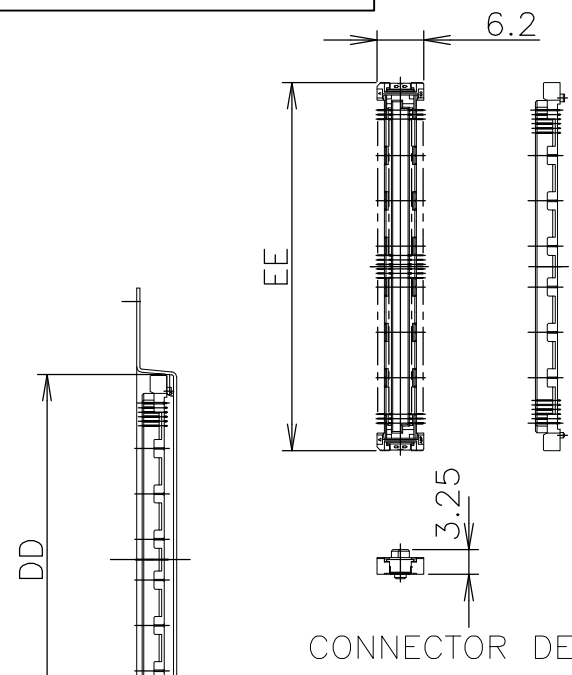
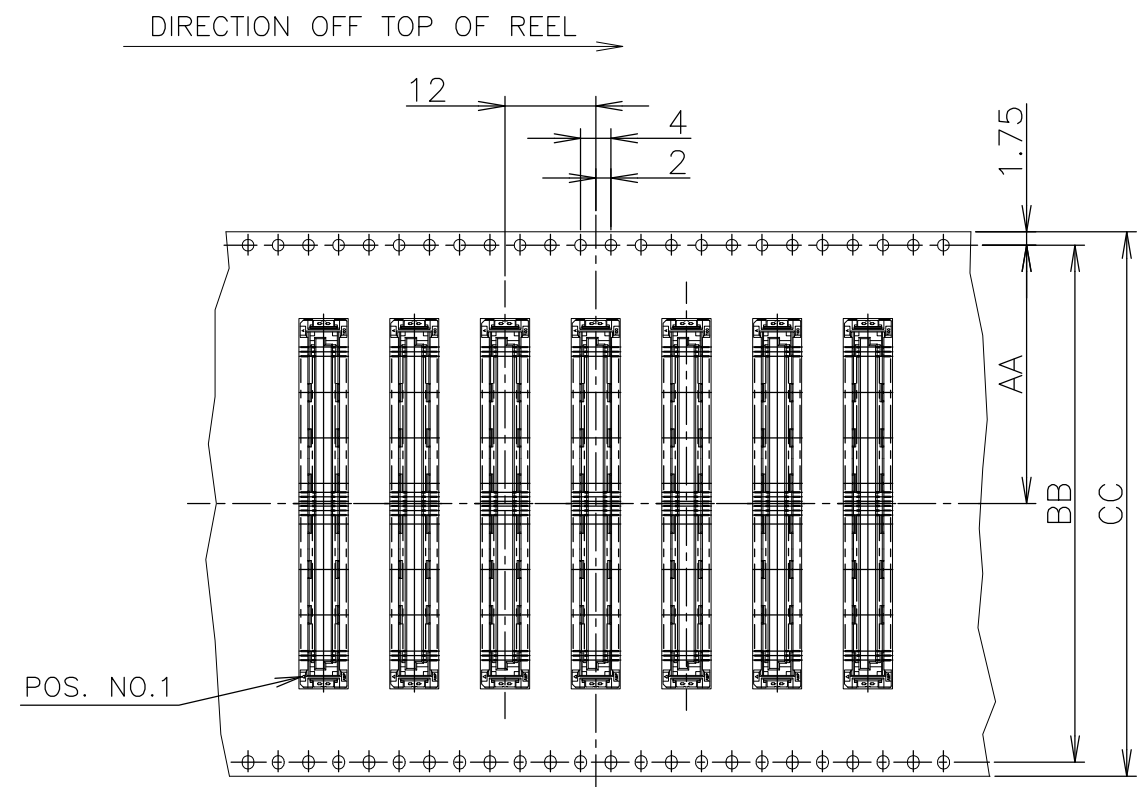

WEEDING THE COVER TAPE AROUND THE OUTER PERIPHERY IN A TURN.

SEALANT	STATUS	QTY.	FINISH	W	EE	DD	CC	BB	AA	POS.	PART NO.
NOT AVAILABLE		1000	△	77.5	54.7	55	72	68.4	34.2	160	6-5353190-1
AVAILABLE				77.5	48.7	49	72	68.4	34.2	140	6- -0
NOT AVAILABLE				61.5	42.7	43	56	52.4	26.2	120	5- -9
AVAILABLE				61.5	36.7	37	56	52.4	26.2	100	5- -8
NOT AVAILABLE				61.5	33.7	34	56	52.4	26.2	90	5- -7
NOT AVAILABLE				49.5	30.7	31	44	40.4	20.2	80	5- -6
NOT AVAILABLE				49.5	27.7	28	44	40.4	20.2	70	5- -5
NOT AVAILABLE				49.5	24.7	25	44	40.4	20.2	60	5- -4
NOT AVAILABLE				37.5	21.7	22	32	28.4	14.2	50	5- -3
NOT AVAILABLE				37.5	18.7	19	32	28.4	14.2	40	5- -2
NOT AVAILABLE		1000	△	29.5	15.7	16	24	11.5	30		5-5353190-1
AVAILABLE		1000	△	77.5	48.7	49	72	68.4	34.2	140	4-5353190-0
AVAILABLE			△	61.5	36.7	37	56	52.4	26.2	100	3- -8
NOT AVAILABLE			△	77.5	54.7	55	72	68.4	34.2	160	1- -1
AVAILABLE				77.5	48.7	49	72	68.4	34.2	140	1- -0
NOT AVAILABLE				61.5	42.7	43	56	52.4	26.2	120	-9
AVAILABLE				61.5	36.7	37	56	52.4	26.2	100	-8
NOT AVAILABLE				61.5	33.7	34	56	52.4	26.2	90	-7
NOT AVAILABLE				49.5	30.7	31	44	40.4	20.2	80	-6
				49.5	27.7	28	44	40.4	20.2	70	-5
				49.5	24.7	25	44	40.4	20.2	60	-4
NOT AVAILABLE				37.5	21.7	22	32	28.4	14.2	50	-3
				37.5	18.7	19	32	28.4	14.2	40	-2
NOT AVAILABLE		1000	△	29.5	15.7	16	24	11.5	30		5353190-1

THIS DRAWING IS A CONTROLLED DOCUMENT.

DWN LEO ZHOU 16NOV04
 CHK STEVEN YAO 16NOV04
 APVD I.ENOMOTO 16NOV04

NAME 名稱
 PRODUCT SPEC 製品規格
 108-60047
 APPLICATION SPEC 取付適用規格
 114-5255

WEIGHT

STE TE Connectivity

EMBOSS ASSY
 FH 0.6BTB CONNECTOR
 REC 4H WITH G-CONTACT

SIZE A3 CAGE CODE 00779 DRAWING NO G-5353190 RESTRICTED TO 番号

CUSTOMER DRAWING SCALE 尺度 1:1 SHEET 1 OF 3 REV E1

THIS DRAWING IS UNPUBLISHED. RELEASED FOR PUBLICATION JUN , 1996.
 © COPYRIGHT 1996 By - ALL RIGHTS RESERVED.

REVISIONS 変更					
P	LTR	DESCRIPTION	DATE	DWN	APVD
-	-	SEE SHEET 1	-	-	-

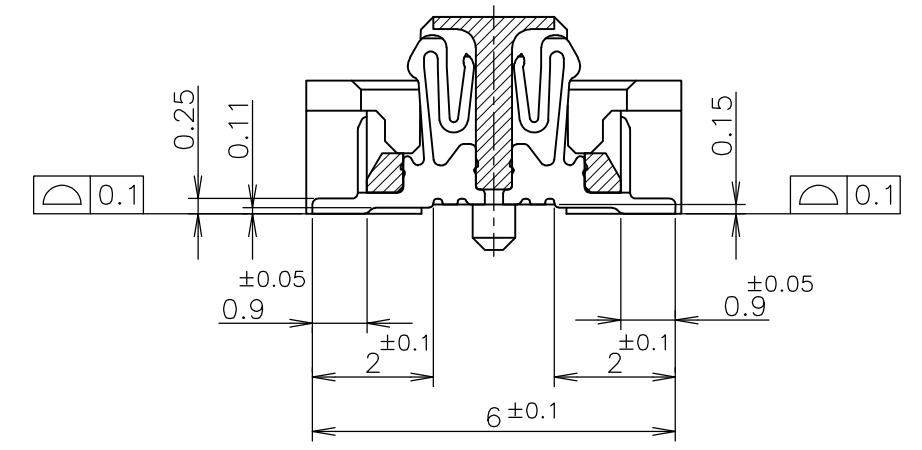
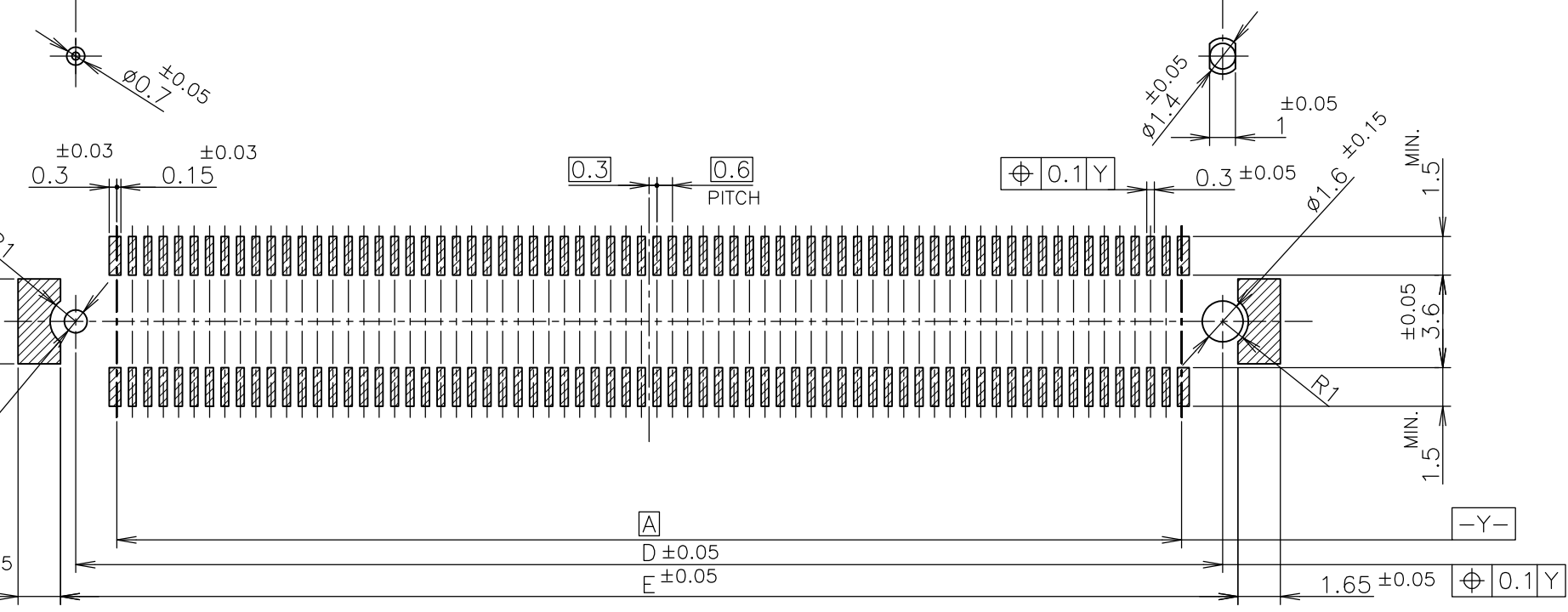
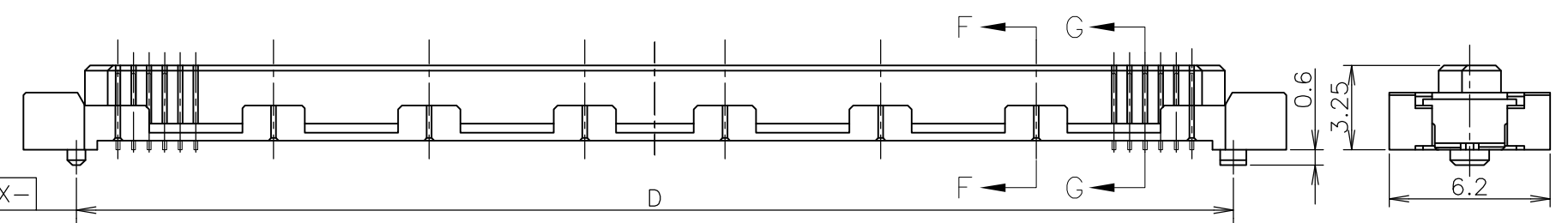
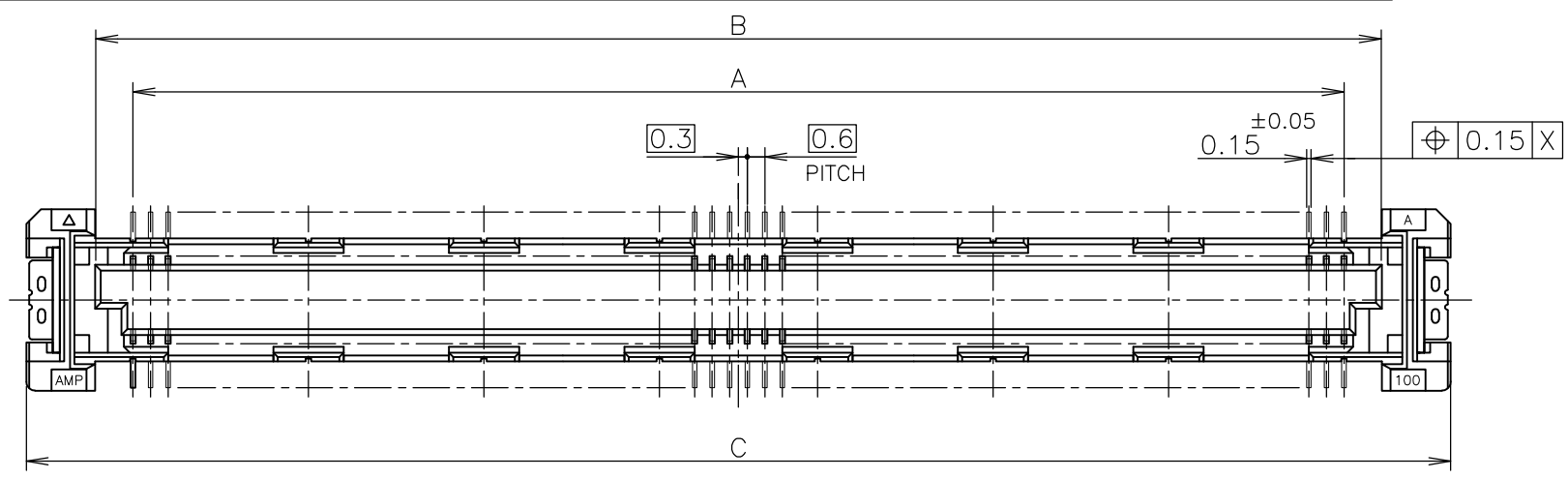

G-G
(SIGNAL POSITION)
(SCALE 8:1)

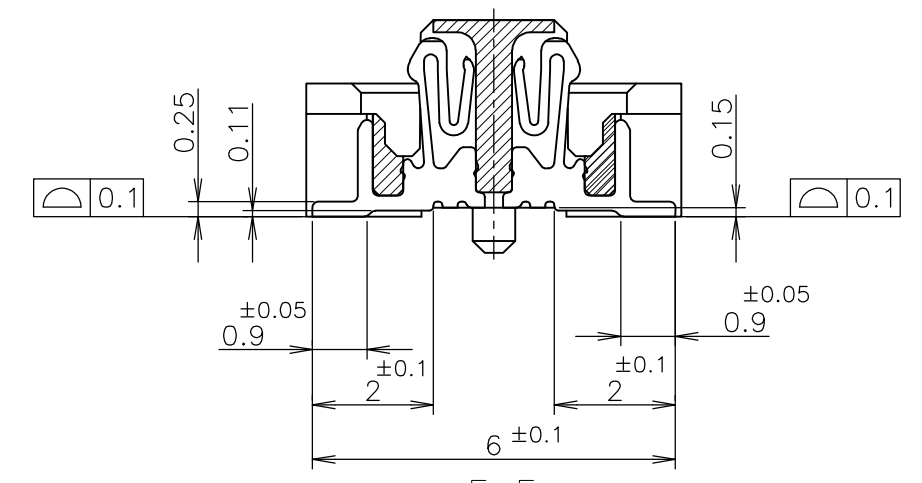

F-F
(GROUND POSITION)
(SCALE 8:1)

45.8	44.6	48.7	44	41.4	140	4-5353190-0
33.8	32.6	36.7	32	29.4	100	3- -8
51.8	50.6	54.7	50	47.4	160	1- -1 & 6-5353190-1
45.8	44.6	48.7	44	41.4	140	1- -0 & 6- -0
39.8	38.6	42.7	38	35.4	120	-9 & 5- -9
33.8	32.6	36.7	32	29.4	100	-8 & 5- -8
30.8	29.6	33.7	29	26.4	90	-7 & 5- -7
27.8	26.6	30.7	26	23.4	80	-6 & 5- -6
24.8	23.6	27.7	23	20.4	70	-5 & 5- -5
21.8	20.6	24.7	20	17.4	60	-4 & 5- -4
18.8	17.6	21.7	17	14.4	50	-3 & 5- -3
15.8	14.6	18.7	14	11.4	40	-2 & 5- -2
12.8	11.6	15.7	11	8.4	30	5353190-1 & 5-5353190-1
E	D	C	B	A	POS	△ PART NO.

REFERENCE P.C.BOARD LAYOUT

THIS DRAWING IS A CONTROLLED DOCUMENT.		DWN	TE Connectivity EMBOSS ASSY FH 0.6BTB CONNECTOR REC 4H WITH G-CONTACT			
DIMENSIONS: 単位: 耗 mm		CHK				NAME 名称
TOLERANCES UNLESS OTHERWISE SPECIFIED: 一般公差		APVD				PRODUCT SPEC 製品規格
0 PLC ± 0.3 1 PLC ± 0.3 2 PLC ± 0.3 3 PLC ± 0.3 4 PLC ± 0.3 ANGLES ± 3°		PRODUCT SPEC 製品規格				APPLICATION SPEC 取付適用規格
MATERIAL 材料		WEIGHT	SIZE	CAGE CODE	DRAWING NO 番号	RESTRICTED TO
FINISH 仕上		CUSTOMER DRAWING	A3	00779	G-5353190	-
		SCALE 尺度	4:1	SHEET 2 OF 3	REV E1	

REVISIONS

変更

P	LTR	DESCRIPTION	DATE	DWN	APVD
-	-	SEE SHEET 1	-	-	-

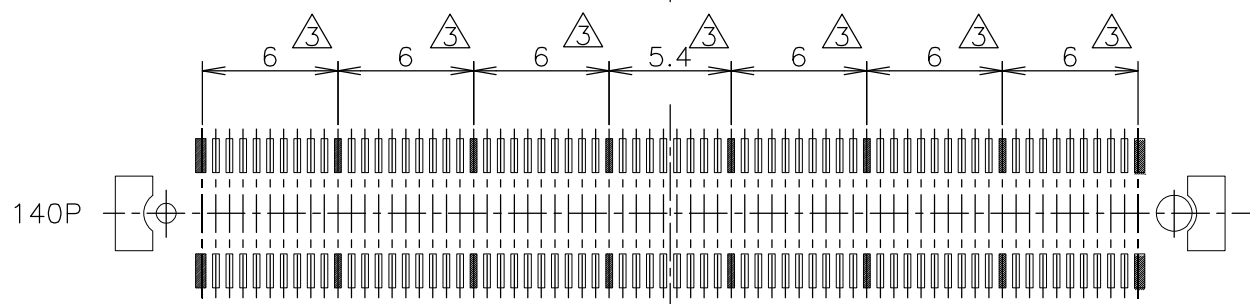
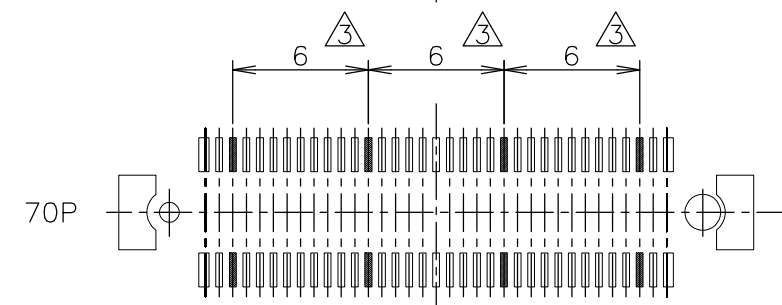
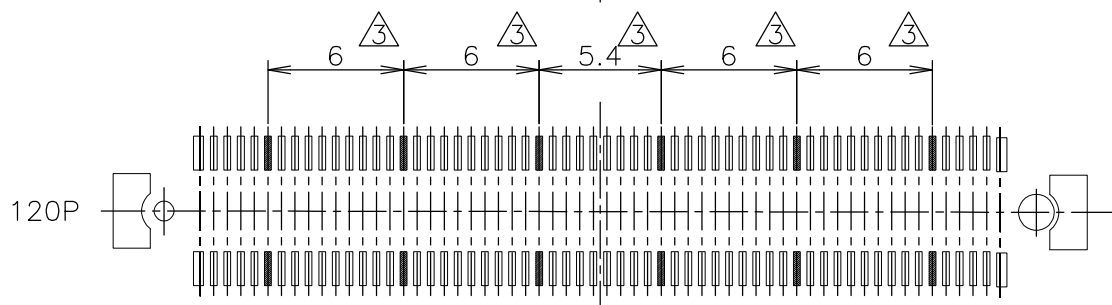
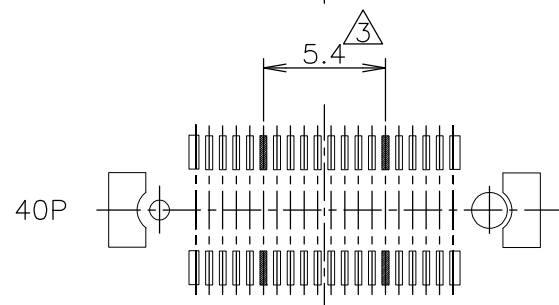
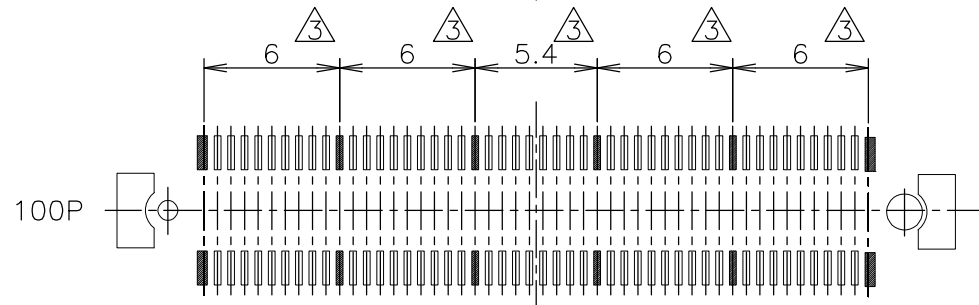
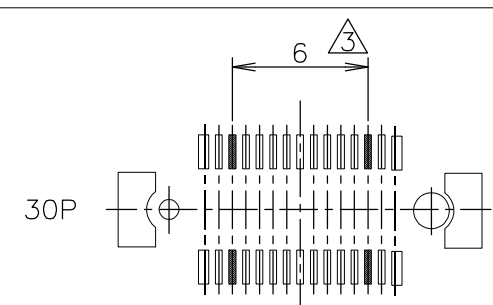
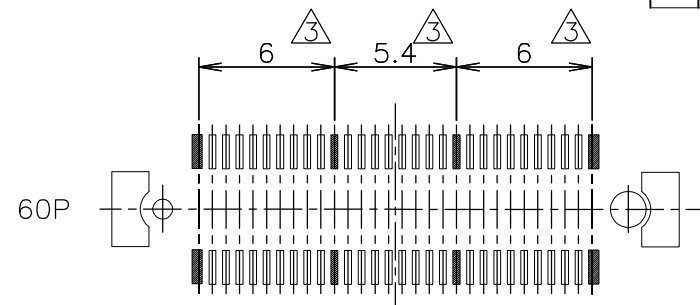
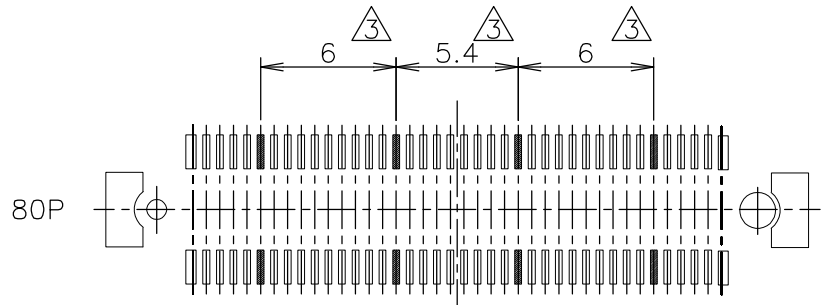

- ① MATERIAL : HOUSING : HIGH TEMP THERMO PLASTIC, UL94V-0
CONTACT : COPPER ALLOY
- ② FINISH : UNDER PL Ni 0.0013mm MIN ALL OVER.
CONTACT AREA 0.0002mm MIN Au PL.
SOLDERING AREA: SIGNAL POS 0.00005mm MIN Au PL.
GROUND POS 0.001mm MIN TIN PL.
- ③ THIS POSITION IS GROUND CIRCUIT.
- ④ PACKING ASSY DWG SEE SHEET 1.
- ⑤ THIS PRODUCT WAS COATED BY FLUX-PENETRATION
-INHIDTING AGENT.
- ⑥ FINISH : UNDER PL Ni 0.0013mm MIN ALL OVER.
CONTACT AREA 0.00076mm MIN Au PL.
SOLDERING AREA: SIGNAL POS 0.00005mm MIN Au PL.
GROUND POS 0.001mm MIN TIN PL.

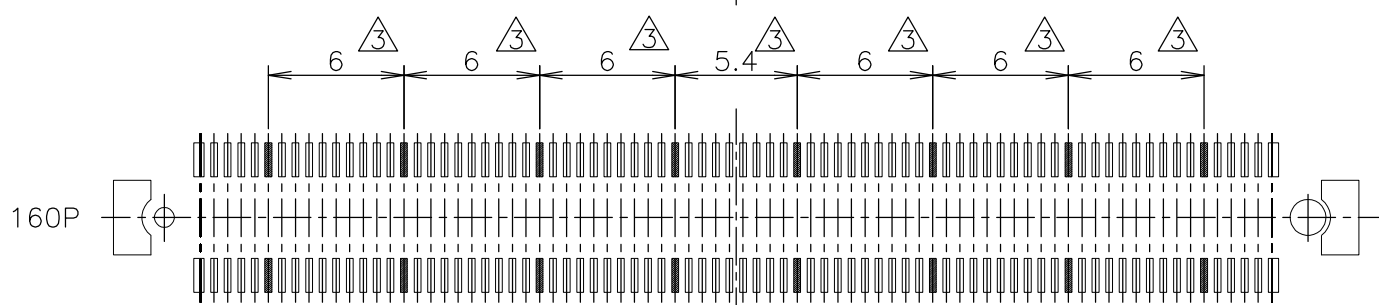

THIS DRAWING IS A CONTROLLED DOCUMENT.

DIMENSIONS:
単位: 耗
mm

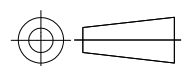

TOLERANCES UNLESS
OTHERWISE SPECIFIED:
一般公差

0 PLC	± 0.3
1 PLC	± 0.3
2 PLC	± 0.3
3 PLC	± 0.3
4 PLC	± 0.3
ANGLES	± 3'

MATERIAL
材料

FINISH
仕上

DWN	
CHK	
APVD	
PRODUCT SPEC 製品規格	
APPLICATION SPEC 取付適用規格	
WEIGHT	
CUSTOMER DRAWING	



NAME 名称				EMBOSS ASSY FH 0.6BTB CONNECTOR REC 4H WITH G-CONTACT	
SIZE	CAGE CODE	DRAWING NO 番号	RESTRICTED TO		
A3	00779	G-5353190	-		
SCALE 尺度		SHEET		REV	
3:1		3 of 3		E1	