

THIS DRAWING IS UNPUBLISHED. RELEASED FOR PUBLICATION
 © COPYRIGHT - BY TYCO ELECTRONICS CORPORATION. ALL RIGHTS RESERVED.

LOC	DIST	REVISIONS					
AG	53	P	LTR	DESCRIPTION	DATE	DWN	APVD
		0		RELEASED.	10OCT2005	JGH	JGH

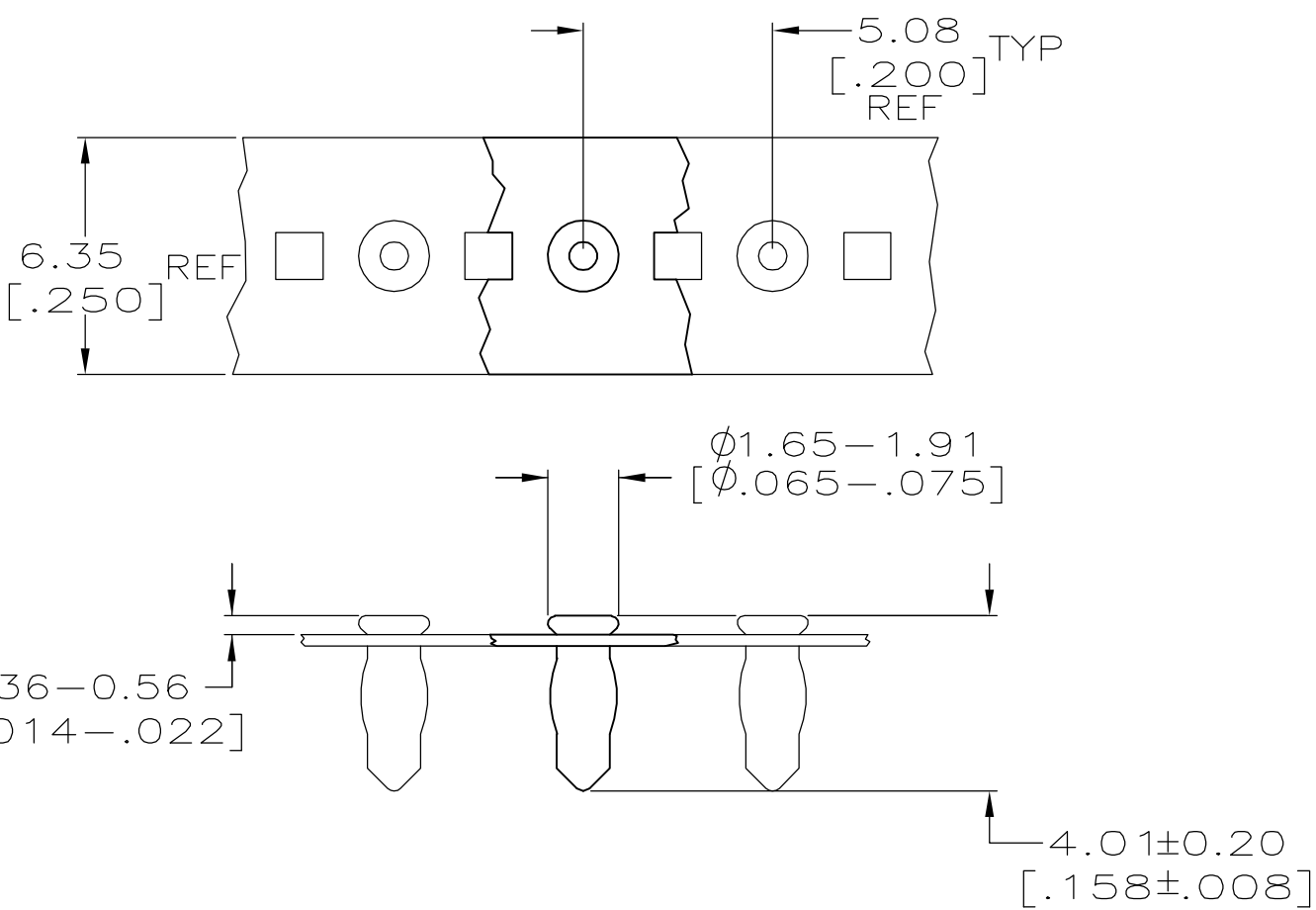

- 1 MATERIAL:
 EYELET - COPPER PER ASTM B 152
 SPRING - BERYLLIUM COPPER PER ASTM B 194
- 2 TIN PLATE PER ASTM B 545 0.00381 [.000150] MIN THICK.
- 3 GOLD PLATE PER ASTM B 488 0.00076 [.000030] MIN THICK ON CONTACT AREA.
- 4 PACKAGED 50,000 PER REEL
- 5. TO INSURE 1/2 OZ MIN RETENTION DO NOT EXCEED 0.10 [.004] DIFFERENCE IN PIN DIA WHEN CHANGING TO A SMALLER DIA PIN
- 6 PRODUCT IS OVALIZED FOR RETENTION IN THE P.C. BOARD. THE RECOMMENDED HOLE DIAMETER IS $\phi 1.32$ [$\phi 0.052$] MINIMUM, +0.08 [+0.003] MAX. PRIOR TO SOLDERING.

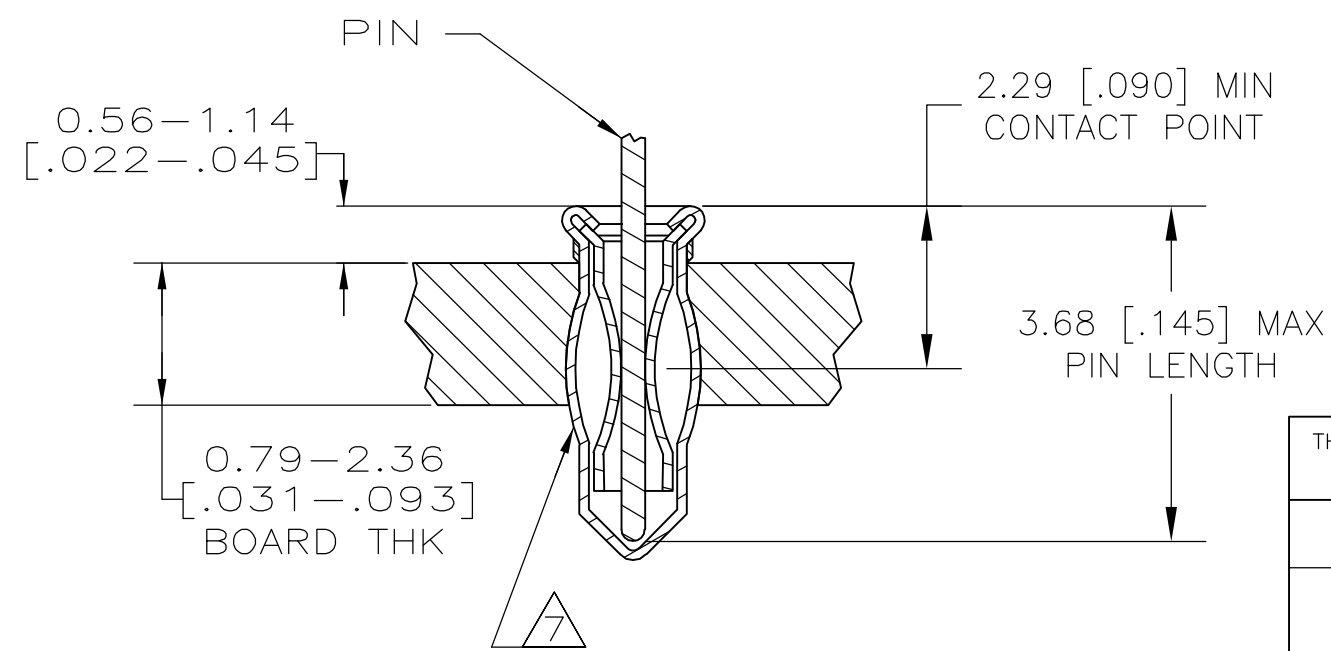

5	2.29-3.68 [.090-.145]	0.36-0.56 [.014-.022]	GOLD 3	TIN 2	5645529-1
PACKAGING	LENGTH	DIA 6	SPRING	EYELET	PART NO
	PIN		FINISH		

THIS DRAWING IS A CONTROLLED DOCUMENT.		DWN J. HAVENER 10OCT2005	Tyco Electronics Corporation Harrisburg, PA 17105-3608		
DIMENSIONS: INCHES		CHK J. HAVENER 10OCT2005			
TOLERANCES UNLESS OTHERWISE SPECIFIED:		APVD J. HAVENER 10OCT2005	NAME MINIATURE SPRING SOCKET ASSEMBLY ON STRIP (SERIES 2)		
0 PLC ± - 1 PLC ± - 2 PLC ± - 3 PLC ± 0.13 [.005] 4 PLC ± - ± - ANGLES ± -		PRODUCT SPEC 108-14008	SIZE A3		
MATERIAL 1		FINISH SEE TABLE	APPLICATION SPEC 114-26004	CAGE CODE 00779	DRAWING NO C=5645529
CUSTOMER DRAWING			WEIGHT -	RESTRICTED TO -	SCALE 10:1
			SHEET 1 OF 1	REV 0	