

# Single Gauge Driver

The 33977 is a Serial Peripheral Interface (SPI) Controlled, stepper motor gauge driver Integrated Circuit (IC). This monolithic IC consists of a dual H-Bridge coil driver and its associated control logic. The H-Bridge drivers are used to automatically control the speed, direction, and magnitude of current through the coils of a two-phase instrumentation stepper motor, similar to an MMT-licensed AFIC 6405 of Switec MS-X156.xxx motor.

The 33977 is ideal for use in instrumentation systems requiring distributed and flexible stepper motor gauge driving. The device also eases the transition to stepper motors from air core motors by emulating the damped air core pointer movement.

### Features

- MMT-Licensed Two-Phase Stepper Motor Compatible
- Switec MS-X15.xxx Stepper Motor Compatible
- Minimal Processor Overhead Required
- Fully Integrated Pointer Movement and Position State Machine with Air Core Movement Emulation
- 4096 Possible Steady State Pointer Positions
- 340° Maximum Pointer Sweep
- Maximum Acceleration of 4500°/s<sup>2</sup>
- Maximum Pointer Velocity of 400°/s
- Analog Microstepping (12 Steps/Degrees of Pointer Movement)
- Pointer Calibration and Return to Zero (RTZ)
- Controlled via 16-Bit SPI Messages
- Internal Clock Capable of Calibration
- Low Sleep Mode Current
- Pb-Free Packaging Designated by suffix code EG

**33977**

**SINGLE GAUGE DRIVER**



**DW SUFFIX  
EG SUFFIX (Pb-FREE)  
98ASB42344B  
24-PIN SOICW**

### ORDERING INFORMATION

Device	Temperature Range (T <sub>A</sub> )	Package
MC33977DW/R2	-40°C to 125°C	24 SOICW
MCZ33977EG/R2		

ARCHIVE INFORMATION

ARCHIVE INFORMATION

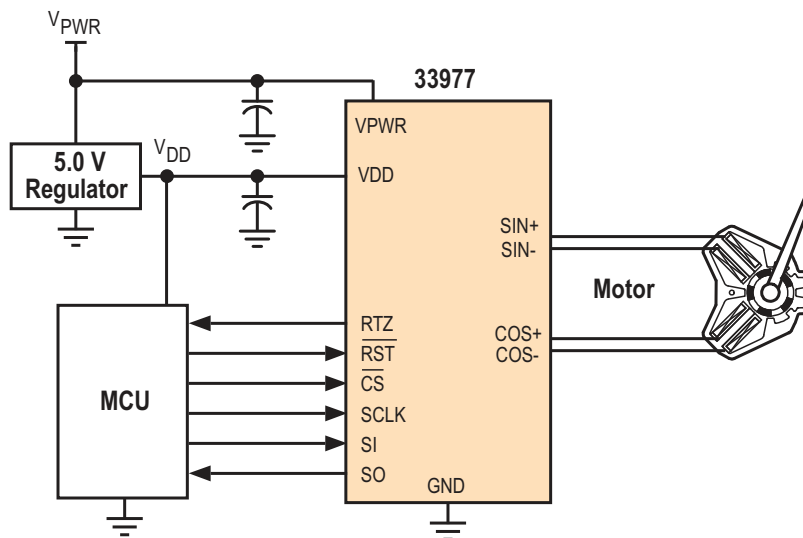

Figure 1. 33977 Simplified Application Diagram

Freescale Semiconductor, Inc. reserves the right to change the detail specifications, as may be required, to permit improvements in the design of its products.

© Freescale Semiconductor, Inc., 2007. All rights reserved.

### INTERNAL BLOCK DIAGRAM

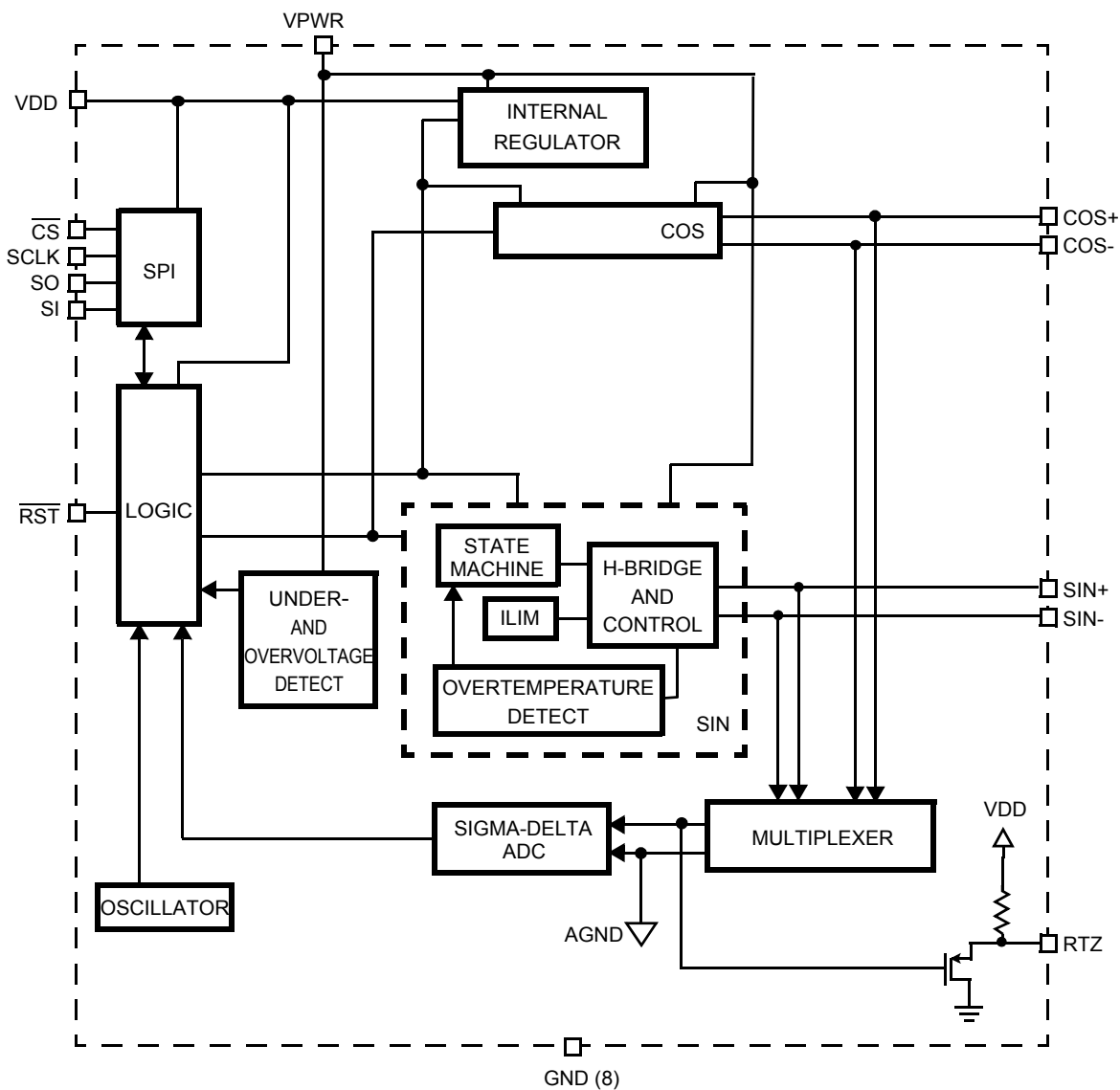

Figure 2. 33977 Simplified Internal Block Diagram

ARCHIVE INFORMATION

ARCHIVE INFORMATION

## PIN CONNECTIONS

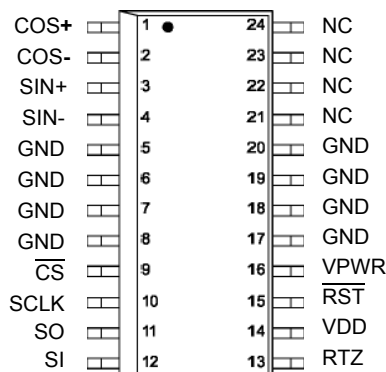

Figure 3. 33977 Pin Connections

Table 1. 33977 Pin Definitions

A functional description of each pin can be found in the Functional Pin Description section beginning on [page 10](#).

Pin	Pin Name	Pin Function	Formal Name	Definition
1 2 3 4	(MS Motor Pin #) COS+ (MS #4) COS- (MS #3) SIN+ (MS #1) SIN- (MS #2)	Output	H-Bridge Outputs 0	Each pin is the output of a half-bridge, designed to source or sink current.
5 to 8, 17 to 20	GND	N/A	Ground	Ground pins
9	$\overline{\text{CS}}$	Input	Chip Select	This pin is connected to a chip select output of a Large Scale Integration (LSI) Master IC and controls which device is addressed.
10	SCLK	Input	Serial Clock	This pin is connected to the SCLK pin of the master device and acts as a bit clock for the SPI port.
11	SO	Output	Serial Output	This pin is connected to the SPI Serial Data Input pin of the Master device or to the SI pin of the next device in a daisy chain.
12	SI	Input	Serial Input	This pin is connected to the SPI Serial Data Output pin of the Master device from which it receives output command data.
13	RTZ	Multiplexed Output	Return to Zero	This is a multiplexed output pin for the non-driven coil, during a Return to Zero (RTZ) event.
14	VDD	Input	Voltage	This SPI and logic power supply input will work with 5.0 V supplies.
15	$\overline{\text{RST}}$	Input	Reset	This pin is connected to the Master and is used to reset the device, or place it into a sleep state by driving it to Logic [1]. When this pin is driven to Logic [0], all internal logic is forced to the default state. This input has an internal active pull-up.
16	VPWR	Input	Battery Voltage	Power supply
21, 22, 23, 24	NC	–	No Connect	These pins are not connected to any internal circuitry, or any other pin, and may be connected to the board where convenient.

## ELECTRICAL CHARACTERISTICS

### MAXIMUM RATINGS

**Table 2. Maximum Ratings**

All voltages are with respect to ground unless otherwise noted. Exceeding these ratings may cause a malfunction or permanent damage to the device.

Ratings	Symbol	Value	Unit
<b>ELECTRICAL RATINGS</b>			
Power Supply Voltage Steady-State	$V_{PWRSS}$	-0.3 to 41	V
Input Pin Voltage <sup>(1)</sup>	$V_{IN}$	-0.3 to 7.0	V
SIN± COSI± Continuous Current Per Output <sup>(2)</sup>	$I_{OUTMAX}$	40	mA
ESD Voltage <sup>(3)</sup>	$V_{ESD}$		V
Human Body Model (HBM)		±2000	
Machine Model (MM)		±2000	
Charge Device Model (CDM)		±200	
<b>THERMAL RATINGS</b>			
Operating Temperature			°C
Ambient	$T_A$	-40 to 125	
Junction	$T_J$	-40 to 150	
Storage Temperature	$T_{STG}$	-55 to 150	°C
Thermal Resistance			°C/W
Junction-to-Ambient	$R_{\theta JA}$	60	
Junction-to-Lead	$R_{\theta JL}$	20	
Peak Package Reflow Temperature During Reflow <sup>(4), (5)</sup>	$T_{PPRT}$	Note 5	°C

**Notes**

- Exceeding voltage limits on Input pins may cause permanent damage to the device.
- Output continuous output rating so long as maximum junction temperature is not exceeded. Operation at 125°C ambient temperature will require maximum output current computation using package thermal resistances.
- ESD testing is performed in accordance with the Human Body Model (HBM) ( $C_{ZAP} = 100$  pF,  $R_{ZAP} = 1500$  Ω), the Machine Model (MM) ( $C_{ZAP} = 200$  pF,  $R_{ZAP} = 0$  Ω), and the Charge Device Model (CDM).
- Pin soldering temperature limit is for 10 seconds maximum duration. Not designed for immersion soldering. Exceeding these limits may cause malfunction or permanent damage to the device.
- Freescale's Package Reflow capability meets Pb-free requirements for JEDEC standard J-STD-020C. For Peak Package Reflow Temperature and Moisture Sensitivity Levels (MSL), Go to [www.freescale.com](http://www.freescale.com), search by part number [e.g. remove prefixes/suffixes and enter the core ID to view all orderable parts. (i.e. MC33xxxD enter 33xxx), and review parametrics.

### STATIC ELECTRICAL CHARACTERISTICS

**Table 3. Static Electrical Characteristics**

Characteristics noted under conditions  $4.75\text{ V} < V_{DD} < 5.25\text{ V}$ , and  $-40^{\circ}\text{C} < T_A < 125^{\circ}\text{C}$ , unless otherwise noted. Typical values noted reflect the approximate parameter means at  $T_A = 25^{\circ}\text{C}$  under nominal conditions unless otherwise noted.

Characteristic	Symbol	Min	Typ	Max	Unit
<b>POWER INPUT (VDD)</b>					
Battery Supply Voltage Range	$V_{PWR}$				V
Fully Operational		6.5	–	26	
Limited Operation (6), (7)		4.0		26	
$V_{PWR}$ Supply Current	$I_{PWR}$				mA
Gauge Outputs ON, No Output Loads		–	4.0	6.0	
$V_{PWR}$ Supply Current (All Outputs Disabled)					$\mu\text{A}$
Reset = Logic [0], $V_{DD} = 5.0\text{ V}$	$I_{PWRSLP1}$	–	42	60	
Reset = Logic [0], $V_{DD} = 0\text{ V}$	$I_{PWRSLP2}$	–	15	25	
Overvoltage Detection Level (8)	$V_{PWROV}$	26	32	38	V
Undervoltage Detection Level (9)	$V_{PWRUV}$	5.0	5.6	6.2	V
Logic Supply Voltage Range (5.0 V Nominal Supply)	$V_{DD}$	4.5	5.0	5.5	V
Under $V_{DD}$ Logic Reset	$V_{DDUV}$	–	–	4.5	V
VDD Supply Current					$\mu\text{V}$
Sleep: Reset Logic [0]	$I_{DDOFF}$	–	40	65	
Outputs Enabled	$I_{DDON}$	–	1.0	1.8	mA
<b>POWER OUTPUT (SIN-, SIN+, COS-, COS+)</b>					
Microstep Output (Measured Across Coil Outputs) SIN± (COS±) (Refer to Pin Definitions on page 3) $R_{OUT} = 200\ \Omega$ , PE6 = 0					V
Steps	Pin Definitions				
6, 18,	0, 12	$V_{ST6}$	4.82	5.3	6.0
5, 7, 17, 19	1, 11, 13, 23	$V_{ST5}$	$0.94 V_{ST6}$	$0.97 V_{ST6}$	$1.0 V_{ST6}$
4, 8, 16, 20	2, 10, 14, 22	$V_{ST4}$	$0.84 V_{ST6}$	$0.87 V_{ST6}$	$0.96 V_{ST6}$
3, 9, 15, 21	3, 9, 15, 21	$V_{ST3}$	$0.68 V_{ST6}$	$0.71 V_{ST6}$	$0.8 V_{ST6}$
2, 10, 14, 22	5, 7, 17, 19	$V_{ST2}$	$0.47 V_{ST6}$	$0.50 V_{ST6}$	$0.57 V_{ST6}$
1, 11, 13, 23	5, 7, 17, 19	$V_{ST1}$	$0.23 V_{ST6}$	$0.26 V_{ST6}$	$0.31 V_{ST6}$
0, 12	6, 18	$V_{ST0}$	0.1	0.0	0.1
Full Step Active Output (Measured Across Coil Outputs) (10) SIN± (COS±), Steps 1,3 (Pin Definitions 0 and 2)	$V_{FS}$	4.9	5.3	6.0	V

**Notes**

- Outputs and logic remain active; however, the larger coil voltage levels may be clipped. The reduction in drive voltage may result in a loss of position control.
- The logic will reset at some level below the specified Limited Operational minimum.
- Outputs will disable and must be re-enabled via the PECCR command.
- Outputs remain active; however, the reduction in drive voltage may result in a loss of position control.
- See [Figure 7](#).

**Table 3. Static Electrical Characteristics** (continued)

Characteristics noted under conditions  $4.75\text{ V} < V_{DD} < 5.25\text{ V}$ , and  $-40^{\circ}\text{C} < T_A < 125^{\circ}\text{C}$ , unless otherwise noted. Typical values noted reflect the approximate parameter means at  $T_A = 25^{\circ}\text{C}$  under nominal conditions unless otherwise noted.

Characteristic	Symbol	Min	Typ	Max	Unit
<b>POWER OUTPUT (SIN-, SIN+, COS-, COS+) (Continued)</b>					
Microstep Full Step Output (Measured from Coil Low Side to Ground) SIN± (COS±) $I_{OUT} = 30\text{ mA}$	$V_{LS}$	0.0	0.1	0.3	V
Output Flyback Clamp <sup>(11)</sup>	$V_{FB}$	–	$V_{ST6} + 0.5$	$V_{ST6} + 1.0$	V
Output Current Limit (Output - $V_{ST6}$ )	$I_{LIM}$	40	100	170	mA
Overtemperature Shutdown <sup>(12)</sup>	$T_{SD}$	155	–	180	$^{\circ}\text{C}$
Overtemperature Hysteresis <sup>(12)</sup>	$T_{HYST}$	8.0	–	16	$^{\circ}\text{C}$
<b>CONTROL I/O (SI, SCLK, CS, RST, SO)</b>					
Input Logic High Voltage <sup>(12)</sup>	$V_{IH}$	2.0	–	–	V
Input Logic Low Voltage <sup>(12)</sup>	$V_{IL}$	–	–	0.8	V
Input Logic Voltage Hysteresis <sup>(12)</sup>	$V_{INHYST}$	–	100	–	mV
Input Logic Pull-Down Current (SI, SCLK)	$I_{DWN}$	3.0	–	20	$\mu\text{A}$
Input Logic Pull-Up Current (CS, RST)	$I_{UP}$	5.0	–	20	$\mu\text{A}$
SO High State Output Voltage ( $I_{OH} = 1.0\text{ mA}$ )	$V_{SOH}$	$0.8 V_{DD}$	–	–	V
SO Low State Output Voltage ( $I_{OL} = 1.6\text{ mA}$ )	$V_{SOL}$	–	0.2	0.4	V
SO Tri-State Leakage Current (CS = 3.5 V)	$I_{SOLK}$	-5.0	0.0	5.0	$\mu\text{A}$
Input Capacitance <sup>(13)</sup>	$C_{IN}$	–	4.0	12	pF
SO Tri-State Capacitance <sup>(13)</sup>	$C_{SO}$	–	–	20	pF
<b>ANALOG TO DIGITAL CONVERTER (RTZ ACCUMULATOR COUNT)</b>					
ADC Gain <sup>(12), (14)</sup>	$G_{ADC}$	100	188	270	Counts/V/ ms

Notes

- Outputs remain active; however, the reduction in drive voltage may result in a loss of position control.
- This parameter is guaranteed by design; however, it is not production tested.
- Capacitance not measured. This parameter is guaranteed by design; however, it is not production tested.
- Reference [RTZ Accumulator \(Typical\) on page 30](#)

**DYNAMIC ELECTRICAL CHARACTERISTICS**
**Table 4. Dynamic Electrical Characteristics**

Characteristics noted under conditions  $4.75\text{ V} < \text{VDD} < 5.25\text{ V}$ , and  $-40^\circ\text{C} < \text{TA} < 125^\circ\text{C}$ , unless otherwise noted. Typical values noted reflect the approximate parameter means at  $T_A = 25^\circ\text{C}$  under nominal conditions unless otherwise noted.

Characteristic	Symbol	Min	Typ	Max	Unit
<b>POWER OUTPUT AND CLOCK TIMINGS (SIN+, SIN-, COS+, COS-) <math>\overline{\text{CS}}</math></b>					
SIN± (COS±) Output Turn ON Delay Time (Time from Rising $\overline{\text{CS}}$ Enabling Outputs to Steady State Coil Voltages and Currents) <sup>(15)</sup>	$t_{\text{DLYON}}$	–	–	1.0	ms
SIN± (COS±) Output Turn OFF Delay Time (Time from Rising $\overline{\text{CS}}$ Disables Outputs to Steady State Coil Voltages and Currents) <sup>(15)</sup>	$t_{\text{DLYOFF}}$	–	–	1.0	ms
Uncalibrated Oscillator Cycle Time	$t_{\text{CLU}}$	0.65	1.0	1.7	μs
Calibrated Oscillator Cycle Time Calibration Pulse = 8.0 μs, PECCR D4 = Logic [0] Calibration Pulse = 8.0 μs, PECCR D4 = Logic [1]	$t_{\text{CLC}}$	1.0 0.9	1.1 1.0	1.2 1.1	μs
Maximum Pointer Speed <sup>(16)</sup>	$V_{\text{MAX}}$	–	–	400	°/s
Maximum Pointer Acceleration <sup>(16)</sup>	$A_{\text{MAX}}$	–	–	4500	°/s <sup>2</sup>
<b>SPI INTERFACE TIMING (<math>\overline{\text{CS}}</math>, SCLK, SO, SI, <math>\overline{\text{RST}}</math>) <sup>(17)</sup></b>					
Recommended Frequency of SPI Operation	$f_{\text{SPI}}$	–	1.0	2.0	MHz
Falling Edge of $\overline{\text{CS}}$ to Rising Edge of SCLK (Required Setup Time) <sup>(18)</sup>	$t_{\text{LEAD}}$	167	–	–	ns
Falling Edge of SCLK to Rising Edge of $\overline{\text{CS}}$ (Required Setup Time) <sup>(18)</sup>	$t_{\text{LAG}}$	167	–	–	ns
SI to Falling Edge of SCLK (Required Setup Time) <sup>(18)</sup>	$t_{\text{SISU}}$	–	25	83	ns
Falling Edge of SCLK to SI (Required Hold Time) <sup>(18)</sup>	$t_{\text{SHOLD}}$	–	25	83	ns
SO Rise Time $C_L = 200\text{ pF}$	$t_{\text{RSO}}$	–	25	50	ns
SO Fall Time $C_L = 200\text{ pF}$	$t_{\text{FSO}}$	–	25	50	ns
SI, $\overline{\text{CS}}$ , SCLK, Incoming Signal Rise Time <sup>(19)</sup>	$t_{\text{RSI}}$	–	–	50	ns
SI, $\overline{\text{CS}}$ , SCLK, Incoming Signal Fall Time <sup>(19)</sup>	$t_{\text{FIS}}$	–	–	50	ns
Falling Edge of $\overline{\text{RST}}$ to Rising Edge of $\overline{\text{RST}}$ (Required Setup Time) <sup>(18)</sup>	$t_{\text{WRST}}$	–	–	3.0	μs
Rising Edge of $\overline{\text{CS}}$ to Falling Edge of $\overline{\text{CS}}$ (Required Setup Time) <sup>(18), (20)</sup>	$t_{\overline{\text{CS}}}$	–	–	5.0	μs
Falling Edge of $\overline{\text{RST}}$ to Rising Edge of $\overline{\text{CS}}$ (Required Setup Time) <sup>(18)</sup>	$t_{\text{EN}}$	–	–	5.0	μs

**Notes**

15. Maximum specified time for the 33977 is the minimum guaranteed time needed from the microcontroller.
16. The minimum and maximum value will vary proportionally to the internal clock tolerance. These numbers are based on an ideally calibrated clock frequency of 1.0 MHz. These are not 100 percent tested.
17. The 33977 shall meet all SPI interface timing requirements specified in the SPI Interface Timing section of this table, over the specified temperature range. Digital interface timing is based on a symmetrical 50 percent duty cycle SCLK Clock Period of 33 ns. The device shall be fully functional for slower clock speeds. Reference [Figure 4](#) and [5](#).
18. The required setup times specified for the 33977 are the minimum time needed from the microcontroller to guarantee correct operation.
19. Rise and Fall time of incoming SI, CS, and SCLK signals suggested for design consideration to prevent the occurrence of double pulsing.
20. The value is for a 1.0 MHz calibrated internal clock. The value will change proportionally as the internal clock frequency changes.

**Table 4. Dynamic Electrical Characteristics** (continued)

Characteristics noted under conditions  $4.75\text{ V} < V_{DD} < 5.25\text{ V}$ , and  $-40^{\circ}\text{C} < T_A < 125^{\circ}\text{C}$ , unless otherwise noted. Typical values noted reflect the approximate parameter means at  $T_A = 25^{\circ}\text{C}$  under nominal conditions unless otherwise noted.

Characteristic	Symbol	Min	Typ	Max	Unit
<b>SPI INTERFACE TIMING (<math>\overline{\text{CS}}</math>, SCLK, SO, SI, <math>\overline{\text{RST}}</math>) (CONTINUED)</b>					
Time from Falling Edge of $\overline{\text{CS}}$ to SO Low Impedance <sup>(22)</sup>	$t_{\text{SOEN}}$	–	–	145	ns
Time from Falling Edge of $\overline{\text{CS}}$ to SO High Impedance <sup>(23)</sup>	$t_{\text{SODIS}}$	–	1.3	4.0	$\mu\text{s}$
Time from Rising Edge of SCLK to SO Data Valid <sup>(24)</sup> $0.2 V_{DD} = \text{SO} = 0.8 V_{DD}$ , $C_L = 200\text{ pF}$	$t_{\text{VALID}}$	–	90	150	ns

Notes

21. The 33977 shall meet all SPI interface timing requirements specified in the SPI Interface Timing section of this table, over the specified temperature range. Digital interface timing is based on a symmetrical 50 percent duty cycle SCLK Clock Period of 33 ns. The device shall be fully functional for slower clock speeds.
22. Time required for output status data to be terminated at SO 1.0 k $\Omega$  load on SO.
23. Time required for output status data to be available for use at SO 1.0 k $\Omega$  load on SO.
24. Time required to obtain valid data out from SO following the rise of SCLK.

ARCHIVE INFORMATION

ARCHIVE INFORMATION

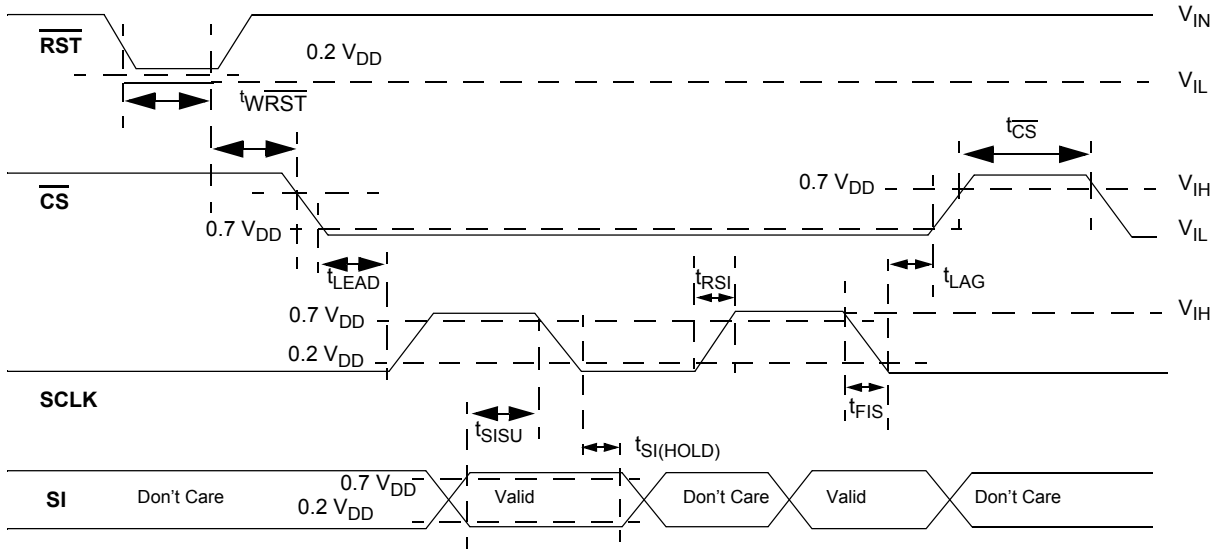
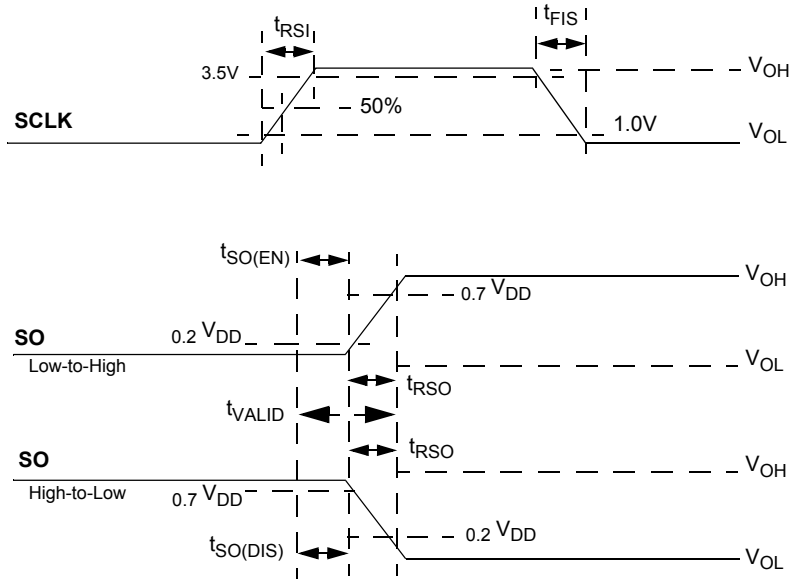

**TIMING DIAGRAMS**

**Figure 4. Input Timing Switching Characteristics**

**Figure 5. Valid Data Delay Time and Valid Time Waveforms**

ARCHIVE INFORMATION

ARCHIVE INFORMATION

## FUNCTIONAL DESCRIPTION

### INTRODUCTION

This 33977 is a single-packaged, Serial Peripheral Interface (SPI) controlled, single stepper motor gauge driver integrated circuit (IC). This monolithic stepper IC consists of [deleted **two** per D. Mortensen] a dual output H-Bridge coil driver [deleted **plural s** for accurate tense] and the

associated control logic. The dual H-Bridge driver is used to automatically control the speed, direction, and magnitude of current through the coils of a two-phase instrumentation stepper motor, similar to an MMT-licensed AFIC 6405 of Switec MS-X 156.xxx motor.

### FUNCTIONAL PIN DESCRIPTION

#### COSINE POSITIVE (COS0+)

The H-Bridge pins linearly drive the sine and cosine coils of a stepper motor, providing four-quadrant operation.

#### COSINE NEGATIVE (COS0-)

The H-Bridge pins linearly drive the sine and cosine coils of a stepper motor, providing four-quadrant operation.

#### SINE POSITIVE (SIN+)

The H-Bridge pins linearly drive the sine and cosine coils of a stepper motor, providing four-quadrant operation.

#### SINE NEGATIVE (SIN-)

The H-Bridge pins linearly drive the sine and cosine coils of a stepper motor, providing four-quadrant operation.

#### GROUND (GND)

Ground pins.

#### CHIP SELECT ( $\overline{CS}$ )

The pin enables communication with the master device. When this pin is in a logic [0] state, the 33977 is capable of transferring information to, and receiving information from, the master. The 33977 latches data in from the Input Shift registers to the addressed registers on the rising edge of  $\overline{CS}$ .

The output driver on the SO pin is enabled when  $\overline{CS}$  is logic [0]. When  $\overline{CS}$  is logic high, signals at the SCLK and SI pins are ignored and the SO pin is tri-stated (high impedance).  $\overline{CS}$  will only be transitioned from a logic [1] state to a logic [0] state when SCLK is logic [0].  $\overline{CS}$  has an internal pull-up ( $I_{UP}$ ) connected to the pin, as specified in the section of the Static Electrical Characteristics Table.

#### SERIAL CLOCK (SCLK)

SCLK clocks the Internal Shift registers of the 33977 device. The SI pin accepts data into the Input Shift register on the falling edge of the SCLK signal, while the Serial Output pin (SO) shifts data information out of the SO Line Driver on the rising edge of the SCLK signal. It is important that the SCLK pin be in a logic [0] state whenever the  $\overline{CS}$  makes any transition.

SCLK has an internal pull down ( $I_{DOWN}$ ), as specified in the section of the Static Electrical Characteristics Table. When  $\overline{CS}$  is logic [1], signals at the SCLK and SI pins are ignored and SO is tri-stated (high impedance). Refer to the data transfer [Timing Diagrams on page 9](#).

#### SERIAL OUTPUT (SO)

The SO data pin is a tri-stateable output from the Shift register. The Status register bits are the first 16 bits shifted out. Those bits are followed by the message bits clocked in FIFO, when the device is in a daisy chain connection or being sent words that are multiples of 16 bits. Data is shifted on the rising edge of the SCLK signal. The SO pin will remain in a high impedance state until the  $\overline{CS}$  pin is put into a logic low state.

#### SERIAL INPUT (SI)

The SI pin is the input of the SPI. Serial input information is read on the falling edge of SCLK. A 16-bit stream of serial data is required on the SI pin, beginning with the most significant bit (MSB). Messages that are not multiples of 16 bits (e.g., daisy chained device messages) are ignored. After transmitting a 16-bit word, the  $\overline{CS}$  pin must be de-asserted (logic [1]) before transmitting a new word. SI information is ignored when  $\overline{CS}$  is in a logic high state.

#### RETURN TO ZERO (RTZ)

This is a multiplexed output pin for the non-driven coil, during a Return to Zero (RTZ) event.

#### VOLTAGE (VDD)

The SPI and logic power supply input will work with 5.0 V supplies.

#### RESET ( $\overline{RST}$ )

If the master decides to reset the device, or place it into a sleep state, the  $\overline{RST}$  pin is driven to a Logic [0]. A Logic [0] on the RST pin forces all internal logic to the known default state. This input has an internal active pull-up.

#### VOLTAGE POWER (VPWR)

This is the power supply pin.

**FUNCTIONAL INTERNAL BLOCK DESCRIPTION (OPTIONAL)**

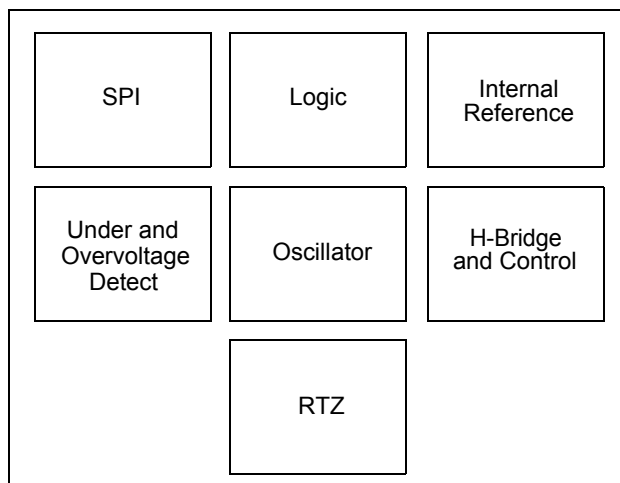

**Figure 6. Functional Internal 33977 Block Illustration**

ARCHIVE INFORMATION

ARCHIVE INFORMATION

**SERIAL PERIPHERAL INTERFACE (SPI)**

This circuitry manages incoming messages and outgoing status data.

**LOGIC**

This design element includes internal logic including state machines and message decoding.

**INTERNAL REFERENCE**

This design element is used for step value levels.

**UNDER AND OVERVOLTAGE DETECTION**

This design element detects when  $V_{PWR}$  is out of the normal operating range.

**OSCILLATOR**

The internal oscillator generates the internal clock for all timing critical features.

**H-BRIDGE AND CONTROL**

This circuitry contains the output coil drivers and the multiplexers necessary for four quadrant operation and RTZ sequencing. This circuitry is repeated for the Sine and Cosine coils.

- Overtemperature — Each output includes an overtemperature sensing circuit
- ILIM — Each output is current limited

**RETURN TO ZERO (RTZ)**

This circuitry outputs the voltage present on the non-driven coil during RTZ operation.

## FUNCTIONAL DEVICE OPERATION

### OPERATIONAL MODES

#### STATE MACHINE OPERATION

The 33977 is ideal for use in instrumentation systems requiring distributed and flexible stepper motor gauge driving. The device also eases the transition to stepper motors from air core motors by emulating the air core pointer movement with little additional processor bandwidth utilization. The two-phase stepper motor has maximum allowable velocities and acceleration and deceleration. The purpose of the stepper motor state machine is to drive the motor with the maximum performance while remaining within the motor's voltage, velocity, and acceleration constraints.

A requirement of the state machine is to ensure the deceleration phase begins at the correct time and pointer position. When commanded, the motor [will deleted PV] accelerates constantly to the maximum velocity, and then it moves toward the commanded position at the maximum velocity. Eventually, the pointer reaches the calculated location where the movement has to decelerate, safely slowing to a stop at the desired position. During the deceleration phase, the motor does [will deleted PV] not exceed the maximum deceleration.

During normal operation, both stepper motor rotors are microstepped at 24 steps per electrical revolution, illustrated in Figure 7. A complete electrical revolution results in two degrees of pointer movement. There is a second smaller [parentheses removed-unnecessary] state machine in the IC controlling these microsteps. The smaller state machine receives *clockwise* or *counter-clockwise* index commands at timed intervals, thereby stepping the motor in the appropriate direction by adjusting the current in each coil. Normalized values are provided in Table 5.

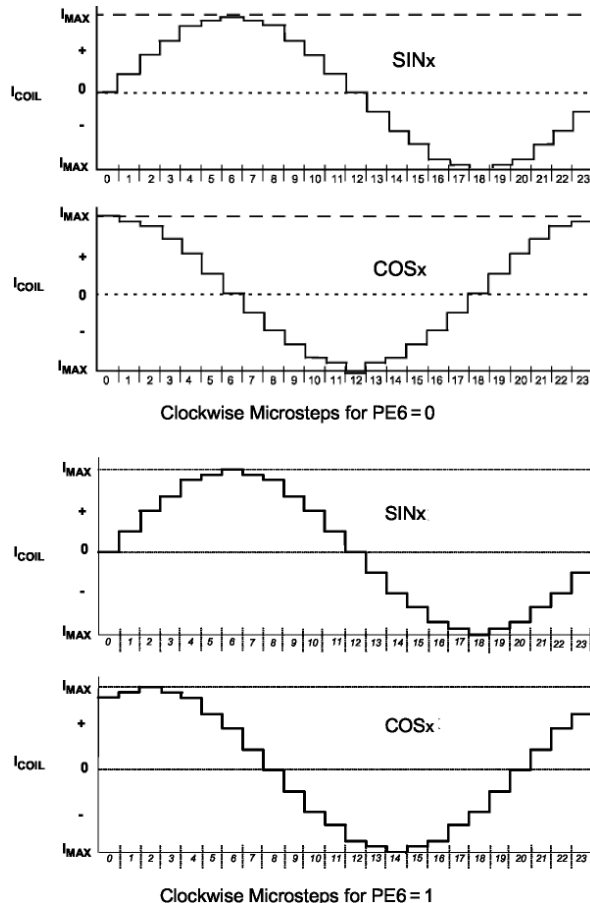

Figure 7. Clockwise Microsteps

Table 5. Coil Step Value

Step	Angle	SINE (Angle)*	COS (Angle -30)* PE6=0	COS (Angle -30)* PE6=1
0	0.0	0.0	1.0	0.866
1	15	0.259	0.965	0.966
2	30	0.5	0.866	1.0
3	45	0.707	0.707	0.966
4	60	0.866	0.5	0.866
5	75	0.966	0.259	0.707
6	90	1.0	0.0	0.500
7	105	0.966	-0.259	0.259
8	120	0.866	-0.5	0.0
9	135	0.707	-0.707	-0.259
10	150	0.5	-0.866	-0.500

**Table 5. Coil Step Value**

11	165	0.259	-0.966	-0.707
12	180	0.0	-1.0	-0.866
13	195	-0.259	-0.966	-0.966
14	210	-0.5	-0.867	-1.0
15	225	-0.707	-0.707	-0.966
16	240	-0.866	-0.5	-0.866
17	255	-0.966	-0.259	-0.707
18	270	-1.0	0.0	-0.500
19	285	-0.966	0.259	-0.259
20	300	-0.866	0.5	0.0
21	315	-0.707	0.707	0.259
22	330	-0.5	0.866	0.500
23	345	-0.259	0.966	0.707

\* Denotes normalized values

The motor is stepped by providing index commands at intervals. The time between steps defines the motor velocity and the changing time defines the motor acceleration.

The state machine uses a table to define the allowed time and the maximum velocity. A useful side effect of the table is that it also allows the direct determination of the position at which the velocity should reduce to stop the motor at the desired position.

Motor motion equations follow: [reworded for efficient use of space]

(The units of position are steps and velocity and acceleration are in steps/second and steps/second<sup>2</sup>.)

From an initial position of 0 with an initial velocity ( $u$ ), the motor position ( $s$ ) at a time ( $t$ ) is:

$$s = ut + \frac{1}{2}at^2$$

For unit steps, the time between steps is:

$$\Rightarrow t = \frac{-u + \sqrt{u^2 + 2a}}{a}$$

This defines the time increment between steps when the motor is initially traveling at a velocity  $u$ . In the ROM, this time is quantized to multiples of the system clock by rounding upwards, ensuring acceleration never exceeds the allowed value. The actual velocity and acceleration is calculated from the time step actually used. Using:

$$v^2 = u^2 + 2as$$

and

$$v = u + at$$

and solving for  $v$  in terms of  $u$ ,  $s$ , and  $t$  gives:

$$v = 2/t - u$$

The correct value of  $t$  to use in the equation is the quantized value obtained above.

From these equations, a set of recursive equations can be generated to give the allowed time step between motor indexes when the motor is accelerating from a stop to its maximum velocity.

Starting from a position  $p$  of 0 and a velocity  $v$  of 0, these equations define the time interval between steps at each position. To drive the motor at maximum performance, index commands are given to the motor at these intervals. A table is generated giving the time step  $*t$  at an index position  $n$ .

$$p_0 = 0$$

$$v_0 = 0$$

$$\Delta t_n = \left\lceil \frac{-v_{n-1} + \sqrt{v_{n-1}^2 + 2a}}{a} \right\rceil$$

where  $\lceil \rceil$  indicates rounding up

$$v_n = 2/\Delta t_n - v_{n-1}$$

$$p_n = n$$

**Note:** [chgd for format consistency AND deleted **that** as PV] For  $p_n = n$ , on the  $n$ th step, the motor [**has** deleted as PV] indexed by  $n$  positions and has been accelerating steadily at the maximum allowed rate. This is critical because it also indicates the minimum distance the motor must travel while decelerating to a stop. For example, the stopping distance is also equal to the current value of  $n$ .

The algorithm of pointer movement can be summarized in two steps:

1. The pointer is at the previously commanded position and is not moving.
2. A command to move to a pointer position (other than the current position) has been received. Timed index pulses are sent to the motor driver at an ever-increasing rate, according to the time steps in [Table 6](#), until:
  - aThe maximum velocity (default or selected) is reached after which the step time intervals will no longer decrease.
  - bThe distance in steps that remain to travel are less than the current step time index value. The motor then decelerates by increasing the step times according to [Table 6](#) until the commanded position is reached. The state machine controls the deceleration so that the pointer reaches the commanded position efficiently.

An example of the velocity table for a particular motor is provided in [Table 6](#). This motor's maximum speed is 4800

microsteps/s (at 12 microsteps/degrees), and its maximum acceleration is 54000 microsteps/s<sup>2</sup>. The table is quantized to a 1.0 MHz clock.

**Table 6. Velocity Table**

Velocity Position	Time Between Steps (μs)	Velocity (μSteps/s)
0	0.0	0.00
1	27217	36.7
2	13607	73.5
3	11271	88.7
4	7970	125.5
5	5858	170.7
6	4564	219.1
7	3720	268.8
8	3132	319.3
9	2701	370.2
10	2373	421.4
11	2115	472.8
12	1908	524.1
13	1737	575.7
14	1594	627.4
15	1473	678.9
16	1369	730.5
17	1278	782.5
18	1199	834.0
19	1129	885.7
20	1066	938.1
21	1010	990.1
22	960	1041.7
23	916	1091.7
24	877	1140.3
25	842	1187.6
26	812	1231.5
27	784	1275.5
28	760	1315.8
29	737	1356.9
30	716	1396.6
31	697	1434.7
32	680	1470.6
33	663	1508.3
34	648	1543.2
35	634	1577.3

Velocity Position	Time Between Steps (μs)	Velocity (μSteps/s)
76	380	2631.6
77	377	2652.5
78	374	2673.8
79	372	2688.2
80	369	2710.0
81	366	2732.2
82	364	2747.3
83	361	2770.1
84	358	2793.3
85	356	2809.0
86	354	2824.9
87	351	2849.0
88	349	2865.3
89	347	2881.8
90	344	2907.0
91	342	2924.0
92	340	2941.2
93	338	2958.6
94	336	2976.2
95	334	2994.0
96	332	3012.0
97	330	3030.3
98	328	3048.8
99	326	3067.5
100	324	3086.4
101	322	3105.6
102	321	3115.3
103	319	3134.8
104	317	3154.6
105	315	3174.6
106	314	3184.7
107	312	3205.1
108	310	3225.8
109	309	3236.2
110	307	3257.3
111	306	3268.0

Velocity Position	Time Between Steps (μs)	Velocity (μSteps/s)
152	257	3891.1
153	256	3906.3
154	255	3921.6
155	254	3937.0
156	254	3937.0
157	253	3952.6
158	252	3968.3
159	251	3984.1
160	250	4000.0
161	249	4016.1
162	248	4032.3
163	248	4032.3
164	247	4048.6
165	246	4065.0
166	245	4081.6
167	244	4098.4
168	244	4098.4
169	243	4115.2
170	242	4132.2
171	241	4149.4
172	241	4149.4
173	240	4166.7
174	239	4184.1
175	238	4201.7
176	238	4201.7
177	237	4219.4
178	236	4237.3
179	265	4255.3
180	235	4255.3
181	234	4273.5
182	233	4291.8
183	233	4291.8
184	232	4310.3
185	231	4329.0
186	231	4329.0
187	230	4347.8

ARCHIVE INFORMATION

ARCHIVE INFORMATION

**Table 6. Velocity Table (continued)**

Velocity Position	Time Between Steps (μs)	Velocity (μSteps/s)
36	621	1610.3
37	608	1644.7
38	596	1677.9
39	585	1709.4
40	575	1739.1
41	565	1769.9
42	555	1801.8
43	546	1831.5
44	538	1858.7
45	529	1890.4
46	521	1919.4
47	514	1945.5
48	507	1972.4
49	500	2000.0
50	493	2028.4
51	487	2053.4
52	481	2079.0
53	475	2105.3
54	469	2132.2
55	464	2155.2
56	458	2183.4
57	453	2207.5
58	448	2232.1
59	444	2252.3
60	439	2277.9
61	434	2304.1
62	430	2325.6
63	426	2347.4
64	422	2369.7
65	418	2392.3
66	414	2415.5
67	410	2439.0
68	406	2463.1
69	403	2481.4
70	399	2506.3
71	396	2525.3
72	393	2544.5
73	389	2570.7
74	386	2590.7
75	383	2611.0

Velocity Position	Time Between Steps (μs)	Velocity (μSteps/s)
112	304	3289.5
113	303	3300.3
114	301	3322.3
115	300	3333.3
116	298	3355.7
117	297	3367.0
118	295	3389.8
119	294	3401.4
120	293	3413.0
121	291	3436.4
122	290	3448.3
123	289	3560.2
124	287	3484.3
125	286	3496.5
126	285	3508.8
127	284	3521.1
128	282	3546.1
129	281	3558.7
130	280	3571.4
131	279	3584.2
132	278	3597.1
133	277	3610.1
134	275	3636.4
135	274	3649.6
136	273	3663.0
137	272	3676.5
138	271	3690.0
139	270	3703.7
140	269	3717.5
141	268	3731.3
142	267	3745.3
143	266	3759.4
144	265	3773.6
145	264	3787.9
146	263	3802.3
147	262	3816.8
148	261	3831.4
149	260	3846.2
150	259	3861.0
151	258	3876.0

Velocity Position	Time Between Steps (μs)	Velocity (μSteps/s)
188	229	4366.8
189	229	4366.8
190	228	4386.0
191	227	4405.3
192	227	4405.3
193	226	4424.8
194	226	4424.8
195	225	4444.4
196	224	4464.3
197	224	4464.3
198	223	4484.3
199	222	4504.5
200	222	4504.5
201	221	4524.9
202	221	4524.9
203	220	4545.5
204	220	4545.5
205	219	4566.2
206	218	4587.2
207	218	4587.2
208	217	4608.3
209	217	4608.3
210	216	4629.6
211	216	4629.6
212	215	4651.2
213	215	4651.2
214	214	4672.9
215	214	4672.9
216	213	4694.8
217	212	4717.0
218	212	4717.0
219	211	4739.3
220	211	4739.3
221	210	4761.9
222	210	4761.9
223	209	4784.7
224	209	4784.7
225	208	4807.7

ARCHIVE INFORMATION

ARCHIVE INFORMATION



### INTERNAL CLOCK CALIBRATION

Timing-related functions on the 33977 (e.g., pointer, velocities, acceleration, and Return to Zero Pointer speeds) depend upon a precise, consistent time reference to control the pointer accurately and reliably. Generating accurate time references on an integrated circuit can be accomplished. There are three methods to generate accurate time references on an integrated circuit:

1. One option is trimming; however, timing tends to be costly due to the large amount of die area required for trim pads.
2. Another, but expensive possibility is an externally generated clock signal. This option requires a dedicated pin on the device and controller.

3. A third, and even more expensive approach requires the use of an additional crystal, or resonator.

The internal clock in the 33977 is temperature independent and area efficient; however, it can vary up to 70 percent due to process variation. Using the existing SPI inputs and the precision timing reference already available to the microcontroller, the 33977 allows more accurate clock calibration to within  $\pm 10$  percent without requiring extra pins, components, or costly circuitry.

Calibrating the internal 1.0 MHz clock is initiated by writing Logic [1] to PECCR bit PE3, illustrated in [Figure 8](#).

ARCHIVE INFORMATION

ARCHIVE INFORMATION

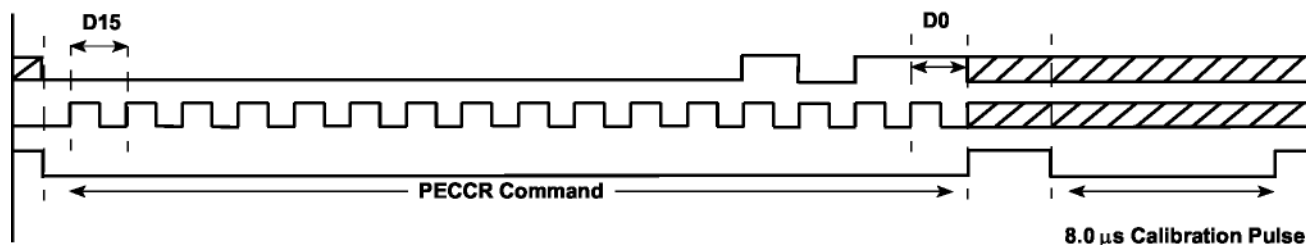

**Figure 8. Gauge Enable and Clock Calibration Example**

The 8.0  $\mu$ s calibration pulse is then provided by the controller to result in a nominal internal 33977 clock speed of 1.0 MHz. The pulse is sent on the  $\overline{CS}$  pin immediately after the SPI calibration command is sent. During the calibration, no other SPI lines should be toggled. At the moment the  $\overline{CS}$  pin transitions from Logic [1] to Logic [0], an internal 7-bit counter counts the number of cycles of an internal, 8.0 MHz clock. The counter stops when the  $\overline{CS}$  pin transitions from Logic [0] to Logic [1]. The value in the counter represents the number of cycles of the 8.0 MHz clock occurring in the 8.0  $\mu$ s window; it should range from 32 to 119. An offset is added to this number to help center, or skew, the calibrated result to generate a desired maximum, or normal frequency. The modified counter value is truncated by four bits to generate the calibration divisor, potentially ranging from four to 15. The 8.0 MHz clock is divided by the calibration divisor, resulting in a calibrated 1.0 MHz clock. If the calibration divisor lies outside the range of four to 15, the 33977 flags the CAL bit in the device Status register, indicating the calibration procedure was not successful. A clock calibration is allowed only if the gauge is disabled, or the pointer is not moving as indicated by the Status bit of MOV, illustrated in [Table 16](#) section of this document.

Some applications may require a guaranteed maximum pointer velocity and acceleration. Guaranteeing these maximums requires the nominal internal clock frequency to

fall below 1.0 MHz. The frequency range of the calibrated clock is always below 1.0 MHz if PECCR bit PE4 is Logic [0] prior to initiating a calibration command, followed by an 8.0  $\mu$ s reference pulse. The frequency is centered at 1.0 MHz if bit D4 is written Logic [1].

The 33977 can be fooled into calibrating faster or slower than the optimal frequency by sending a calibration pulse longer or shorter than the intended 8.0  $\mu$ s. As long as the calibration divisor remains between four and 15 there is no calibration flag. For applications requiring a slower calibrated clock, e.g., a motor designed with a gear ratio of 120:1 (8 microsteps/deg), users will have to provide a longer calibration pulse. The internal oscillator can be slowed with the PECCR command, so the calibration divisor safely falls within the four to 15 range when calibrating with a longer time reference. For example, for the 120:1 motor, the pulse would be 12  $\mu$ s instead of 8.0  $\mu$ s. The result of this slower calibration is longer step times resulting in generating pointer movements capable of meeting acceleration and velocity requirements. The resolution of the pointer positioning decreases from 0.083 deg/microstep (180:1) to 0.125 deg/microstep (120:1) while the pointer sweep range increases from approximately 340° to over 500°.

**Note:** A fast calibration could result in violations of the motor acceleration and a velocity maximums, resulting in missed steps.



## POINTER DECELERATION

Constant acceleration and deceleration of the pointer produces relatively choppy movements when compared to those of an air core gauge. Modification of the velocity position ramp during deceleration can create the desired damped movement. This modification is accomplished in the 33977 by adding repetitive steps at several of the last velocity

position step values as the pointer decelerates. The default movement in the 33977 uses this ramp modification feature. An example is illustrated in [Figure 9](#). If the maximum acceleration and deceleration of the pointer is desired, the repetitive steps can be disabled by writing Logic [1] to the PECCR bit PE5.

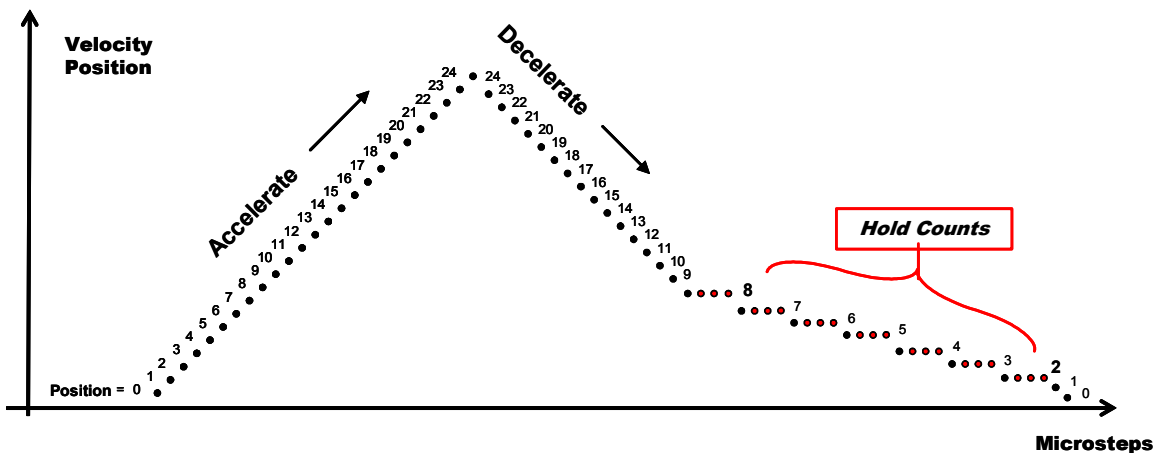

Figure 9. Deceleration Ramp

## RETURN TO ZERO CALIBRATION

Many stepper motor applications require ~~that~~ the IC detect when the stepper motor stalls after commanded to return to the zero position for calibration purposes. In instrumentation applications, the stalling occurs when the pointer hits the end stop on the gauge bezel, ~~which is~~ usually at the zero position. It is important to know ~~that~~ when the pointer reaches the end stop, it immediately stops without bouncing away. The 33977 device provides the ability to automatically and independently return the pointer to the zero position via the RTZR and RTZCR SPI commands. An automatic RTZ is initiated, using the RZ1 and RZ2 bits, provided the RZ4 is Logic [1]. During an RTZ event, all commands related to the gauge being returned are ignored until the pointer has successfully zeroed, or the RTZR bit RZ1 is written to disable the event. Once an RTZ event is initiated, the device reports back via the SO pin an RTZ event is underway.

The RTZCR command is used to set the RTZ pointer speed, choose an appropriate blanking time, and preload the integration accumulator with an appropriate offset. On reaching the end stop, the device reports back to the microcontroller via the status message ~~that~~ the RTZ was successful. The RTZ automatically disables, ~~that will~~ allowing other commands to be valid. In the event the master

determines an RTZ sequence is not working properly, for example, the RTZ taking too long; it can disable the command via the RTZR bit RZ1. [Altered for better read flow]

RTZCR bits RC10:RC5 are written to preload the accumulator with a predetermined value assuring accurate pointer stall detection. This preloaded value can be determined during application development by disabling the automatic shutdown feature of the device with the RTZR bit RZ4. This operating mode allows the master to monitor the RTZ event, using the accumulator information available via the SO if the device is configured to provide the RTZ Accumulator Status. The unconditional RTZ event can be turned OFF using the RTZR bit RZ1.

If the Position 0 location bit, RZ2, is in the default Logic [0] mode, then during an RTZ event the pointer is returned counterclockwise (CCW) using full steps at a constant speed determined by the RTZCR RC3:RC0 and RC12:RC11 bits written during RTZ configuration, see [Figure 10](#). Full steps are used during an RTZ so only coil of the motor is being driven at any time. The coil not being driven is used to determine if the pointer is moving. If the pointer is moving, the flux present in the non-driven coil is processed by integrating the back EMF signal present on the opened pin of the coil while applying a fixed potential to the other end.

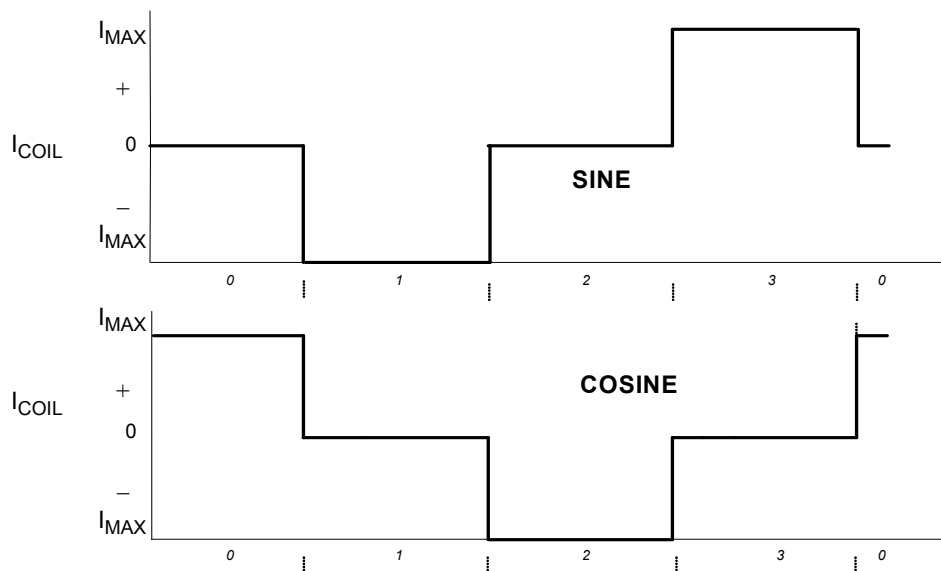

**Figure 10. Full Steps (Counterclockwise)**

The IC automatically prepares the non-driven coil at each step, waits for a predetermined blanking time, and then processes the signal for the duration of the full step. When the pointer reaches the stop and not longer moves, the dissipating flux is detected. The processed results are placed in the RTZ accumulator, and then compared to a decision threshold. If the signal exceeds the decision threshold, the pointer is assumed to be moving. If the threshold value is not exceeded, the drive sequence is stopped if RTZR bit RZ4 is Logic [0]. If bit RZ4 is Logic [1], the RTZ movement will continue indefinitely until the RTZR bit RZ1 is used to stop the RTZ event.

A pointer [that is PV] not on a full step location, or [that PV] is in magnetic alignment prior to the RTZ event may cause a false RTZ detection. More specifically, an RTZ event beginning from a non-full step position may result in an abbreviated flux value potentially interpreted as a stalled pointer. Advancing the pointer by at least 12 microsteps clockwise (if PE7 = 0) to the nearest full step position (e.g., 0, 6, 12, 18, 24, etc.) prior to initiating an RTZ ensures the magnetic fields line up and increases the chances of a successful pointer stall detection. It is important that the pointer be in a static, or commanded, position before starting the RTZ event. Because the time duration and the number of steps the pointer moves prior to reaching the commanded position can vary depending upon its status at the time a position change is communicated, the master should make sure that the rotor is not moving prior to starting an RTZ. Cessation of movement can be inferred by monitoring the CMD and/or the MOV status bits.

It should be pointed out, the flux value, for an ideal motor with the coils perfectly aligned at 90°, will vary little from full step to full step if all other variables, such as temperature, are

held constant. The full steps are evenly spaced, resulting in equidistant movement as the motor is full stepped.

In comparison, motors [that have deleted PV] whose coils aligned at a 60° angle [will deleted PV] results in two distinct flux values as the coils are driven in the same full step fashion. This lack of symmetry in the measured flux is due to the difference in the electrical angles between full steps. Clearly stated, the distance the rotor moves changes from full step to full step. This difference can be observed in [Figure 7](#) and [Table 5](#).

In [Figure 7](#), where PE6 = 0, the difference in microsteps between alternating full steps (one coil at maximum current while the other is at zero) is always six. In contrast, the same figure illustrates PE6 = 1 showing the difference in microsteps between full steps of the 60° coils alternating between four and eight. These expected differences should be taken into account when setting the RTZ threshold.

After completion of an RTZ, the 33977 automatically assigns the zero step position to the full step position at the end-stop location. Because the actual zero position could lie anywhere within the full step where the zero was detected, the assigned zero position could be within a window of ±0.5°. An RTZ can be used to detect stall, even if the pointer rests on the end-stop when RTZ sequence is initiated. However, it is recommended to advance the pointer by at least 12 microsteps to the nearest full step prior to initiating the RTZ.

### RTZ OUTPUT

During an RTZ event the non-driven coil is analyzed to determine the state of the motor. The 33977 multiplexes the coil voltages, [chgd PV and provides to read as active voice] providing signal from the non-driven coil to the RTZ pin.

## DEFAULT MODE

Default mode refers to the state of the 33977 after an internal or external reset prior to SPI communication. An internal reset occurs during  $V_{DD}$  power-up or if  $V_{PWR}$  falls below 4.0 V. An external reset is initiated by the RST pin driven to Logic [0]. With the exception of the RTZCR full step time, all of the specific pin functions and internal registers will operate as though all of the addressable configuration register bits were set to Logic [0]. This means, for example, [deleted PV that] the outputs will be disabled after a power-up or external reset, and SO flag OD6 and OD8 are set, indicating an undervoltage event. Anytime an external reset is exerted and the default is restored, all configuration parameters [replaced e.g. with such as] such as clock calibration, maximum speed, and RTZ parameters are lost and must be reloaded.

## FAULT LOGIC REQUIREMENTS

The 33977 device indicates each of the following faults as they occur:

- Overtemperature fault
- Undervoltage  $V_{PWR}$
- Overvoltage  $V_{PWR}$
- Clock Out of Specification [Formalized spec]

These fault bits remain enabled until they are clocked out of the SO pin with a valid SPI message.

Overcurrent faults are not reports directly; however, it is likely an overcurrent condition will become a thermal issue and be reported.

## OVERTEMPERATURE FAULT REQUIREMENTS

The 33977 incorporates overtemperature protection circuitry, shutting off the gauge driver when an excessive temperature is detected. In the event of a thermal overload, the gauge driver is automatically disabled and the fault is flagged via the OT device status bit. The indicating flag

continues to be set until the gauge is successfully re-enacted, provided the junction temperature has fallen below the hysteresis level.

## OVERVOLTAGE FAULT REQUIREMENTS

The device is capable of surviving  $V_{PWR}$  voltages within the maximum specified in *Maximum Ratings*, [Table 2](#).  $V_{PWR}$  levels resulting in an overvoltage shutdown condition can result in uncertain pointer positions. Therefore, the pointer position should be re-calibrated. The master will be notified of an overvoltage event via the SO pin if the device status is selected. Overvoltage detection and notification occurs regardless of whether the gauge(s) are enabled or disabled.

## OVERCURRENT FAULT REQUIREMENTS

Outcome currents are limited to safe levels allowing the device to rely on thermal shutdown to protect itself.

## UNDERVOLTAGE FAULT REQUIREMENTS

Undervoltage  $V_{PWR}$  conditions may result in uncertain pointer positions. Therefore, the internal clock and the pointer position may require re-calibration. The state machine continues to operate with  $V_{PWR}$  voltage levels as low as 4.0 V; however, the coil voltages may be clipped. Notification of an undervoltage event is provided via the SO pin.

## RESET (SLEEP MODE)

The device can reset internally or externally. If the  $V_{DD}$  level falls below the  $V_{DDUV}$  level, the device resets and powers up in the Default mode. See *Static Electrical Characteristics* table under the sub-heading: *Power Input* in [Table 3](#). Similarly, if the RST pin is driven to Logic [0], then the device resets to its default state. The device consumes the least amount of current ( $I_{DD}$  and  $I_{PWR}$ ) when the RST pin is Logic [0]. This is also referred to as the Sleep mode.

## LOGIC COMMANDS AND REGISTERS

### SPI PROTOCOL DESCRIPTION

The SPI interface has a full-duplex, three-wire synchronous, 16-bit serial synchronous interface data transfer and four I/O lines associated with it: Chip Select ( $\overline{CS}$ ), Serial Clock (SCLK), Serial Input (SI), and Serial Output (SO). The SI/SO pins of the 33977 follow a first in/first out (D15/D0) protocol with both input and output words transferring the most significant bit first. All inputs are compatible with 5.0 V CMOS logic levels.

#### CHIP SELECT ( $\overline{CS}$ )

The  $\overline{CS}$  pin enables communication with the master device.

When this pin is in a Logic [0] state, the 33977 is capable of transferring information to, and receiving information from, the master. The 33977 latches data in from the Input Shift registers to the addressed registers on the rising edge of  $\overline{CS}$ . The output driver on the SO pin is enabled when  $\overline{CS}$  is Logic [0]. When  $\overline{CS}$  is logic high, signals at the SCLK and SI pins are ignored and the SO pin is tri-stated (high impedance).  $\overline{CS}$  will only be transitioned from a Logic [1] state to a Logic [0] state when SCLK is Logic [0].  $\overline{CS}$  has an internal pull-up ( $I_{UP}$ ) connected to the pin, as specified in the section of the Static Electrical Characteristics table entitled CONTROL I/O, **[which is found on page...deleted for consistent format]** [Table 3](#). This pin is also used to calibrate the internal clock.

#### SERIAL CLOCK (SCLK)

SCLK clocks the Internal Shift registers of the 33977 device. The SI pin accepts data into the Input Shift register on the falling edge of the SCLK signal, while the Serial Output pin (SO) shifts data information out of the SO line driver on the rising edge of the SCLK signal. It is important the SCLK pin be in a Logic [0] state whenever the  $\overline{CS}$  makes any transition. SCLK has an internal pull-down ( $I_{DWN}$ ), as specified in the section *Control I/O* of the Static Electrical Characteristics, **[which is found on page...deleted for consistent format]** [Table 3](#). When  $\overline{CS}$  is Logic [1], signals at the SCLK and SI pins are ignored and SO is tri-stated (high impedance). Refer to the data transfer timing diagrams in

[Figure 11](#) and [Figure 12](#). [figure numbers changed due to template formatting]

It transitions one time per bit transferred at an operating frequency,  $f_{SPI}$ , defined in the SPI Interface Timing section of the Dynamic Electrical Characteristics [Table 4](#). It is idle between command transfers. The pin is 50 percent duty cycle, with CMOS logic levels. This signal is used to shift data to and from the device.

#### SERIAL OUTPUT (SO)

The SO data pin is a tri-stateable output from the Shift register. This output will remain tri-stated unless the device is selected by a low  $\overline{CS}$  signal. The output signal generated will have CMOS logic levels and the output will transition on the rising edges of SCLK. The serial output data provides status feedback and fault information for each output and is returned MSB first when the device is addressed.

The Status register bits are the first 16 bits shifted out. Those bits are followed by the message bits clocked in FIFO, when the device is in a daisy chain connection, or being sent words **[that are deleted as PV]** multiples of 16 bits. Data is shifted on the rising edge of the SCLK signal. The SO pin **[will deleted as PV]** remains in a high impedance state until the  $\overline{CS}$  pin is put into a logic low state.

#### SERIAL INPUT (SI)

The SI pin is the input of the SPI. This input has an internal active pull-down requiring CMOS logic levels. The serial data transmitted on this line is a 16-bit control command sent MSB first, controlling the gauge functions. The master ensures data is available on the falling edge of SCLK.

Serial input information is read on the falling edge of SCLK. A 16-bit stream of serial data is required on the SI pin, beginning with the most significant bit (MSB). Messages **[that are deleted as PV]** not multiples of 16 bits (e.g., daisy chained device messages) are ignored. After transmitting a 16-bit word, the  $\overline{CS}$  pin must be de-asserted (Logic [1]) before transmitting a new word. SI information is ignored when  $\overline{CS}$  is in a logic high state.

This section provides a description of the 33977 SPI behavior. To follow the explanation below, please refer to

Table 7 and to the timing diagrams illustrated in Figure 11 and Figure 12.

**Table 7. Data Transfer Timing**

Pin	Description
$\overline{CS}$ (1-to-0)	SO pin is enabled
$\overline{CS}$ (0-to-1)	33977 configuration and desired output states are transferred and executed according to the data in the Shift registers
SO	Will change state on the rising edge of the SCLK pin signal
SI	Will accept data on the falling edge of the SCLK pin signal

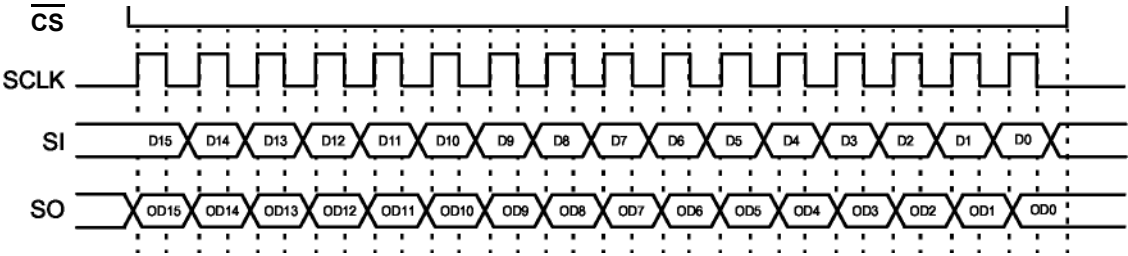

Output Shift register is loaded here  
Note: SO is tri-stated when  $\overline{CS}$  is Logic [1]

**Figure 11. Single 16-Bit Word SPI Communication**

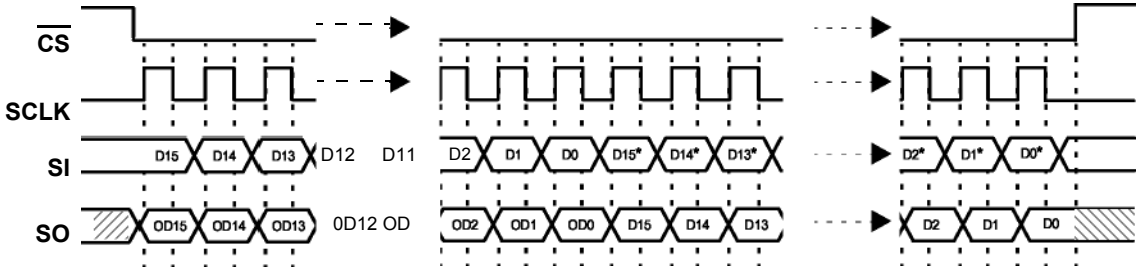

- Notes:
1. SO is tri-stated when  $\overline{CS}$  is Logic [1].
  2. D15, D14, D13, , and D0 refer to the first 16 bits of data into the 33977.
  3. D15\*, D14\*, D13\*, . . . , and D0\* refer to the most recent entry of program data into the 33977.
  4. OD15, OD14, OD13, . . . ,and OD0 refer to the first 16 bits of fault and status data out of the 33977.

**Figure 12. Multiple 16-Bit Word SPI Communication**

**DATA INPUT**

The Input Shift register captures data at the falling edge of the SCLK. The SCLK pulses exactly 16 times only inside the transmission windows ( $\overline{CS}$  in a Logic [1] state). By the time the  $\overline{CS}$  signal goes to Logic [1] again, the contents of the Input Shift register are transferred to the appropriate internal register addressed in bits 15:13. The minimum time  $\overline{CS}$  should be kept high depends on the internal clock speed, specified in the SPI Interface Timing section of the [Static replaced with Dynamic - correcting table location] Dynamic Electrical Characteristics, Table 4. It must be long enough so the internal clock is able to capture the data from the Input Shift register and transfer it to the internal registers.

**DATA OUTPUT**

At the first rising edge of the SCLK [clock deleted to eliminate redundancy], with  $\overline{CS}$  at Logic [1], the contents of the selected Status Word register are transferred to the Output Shift register. The first 16 bits clocked out are the status bits. If data continues to clock in before the  $\overline{CS}$  transitions to Logic [1], the device begins to shift out the data previously clocked in FIFO after the  $\overline{CS}$  first transitioned to Logic[1].

**COMMUNICATION MEMORY MAPS AND REGISTER DESCRIPTIONS**

The 33977 device is capable of interfacing directly with a microcontroller via the 16-bit SPI protocol specified below.

ARCHIVE INFORMATION

ARCHIVE INFORMATION



The device is controlled by the microprocessor and reports back status information via the SPI. This section provides a detailed description of all registers accessible via serial interface. The various registers control the behavior of this device.

A message is transmitted by the master beginning with the MSB (D15) and ending with the LSB (D0). Multiple messages can be transmitted in succession to accommodate those applications where daisy chaining is desirable, or to confirm transmitted data, as long as the messages are all multiples of 16 bits. Data is transferred through daisy-chained devices, as illustrated in [Figure 12](#). If an attempt is made to latch in a message smaller than 16 bits wide, it is ignored.

**Table 8** lists the five registers the 33977 uses to configure the device, control the state of the [Chgd to **two** per D. Mortensen] two H-bridge outputs, and determine the type of status information [that is deleted PV] clocked back to the master. The registers are addressed via D15:D13 of the incoming SPI word.

**Table 8. Module Memory Map**

Address [15:13]	Register	Name	See
000	Power, Enable, Calibration, and Configuration Register	PECCR	<a href="#">Table 9</a>
001	Maximum Velocity Register	VELR	<a href="#">Table 10</a>
010	Gauge Position Register	POSR	<a href="#">Table 11</a>
011	Not Used	–	–
100	Return to Zero Register	RTZR	<a href="#">Table 12</a>
101	Return to Zero Configuration Register	RTZCR	<a href="#">Table 13</a>
110	Not Used	RMPSELR	–
111	Reserved for Test	–	–

[The word Zero omitted above in 101 my error]

### MODULE MEMORY MAP

Various registers of the 33977 SPI module are addressed by the three MSBs of the 16-bit word received serially. Functions to be controlled include:

- Individual gauge drive enabling
  - Power-up/down
  - Internal clock calibration
  - Gauge pointer position and velocity
  - Gauge pointer zeroing
  - Air core motor movement emulation
  - Status information
- Status reporting includes:
- Individual gauge overtemperature condition

- Battery overvoltage
- Battery undervoltage
- Pointer zeroing status
- Internal clock status
- Confirmation of pointer movement commands
- Real time pointer position information
- Real time pointer velocity step information
- Pointer movement direction
- Command pointer position status
- RTZ accumulator value

### REGISTER DESCRIPTIONS

The following section describes the registers, their addresses, and their impact on device operation.

#### ADDRESS 000 - POWER, ENABLE, CALIBRATION, AND CONFIGURATION REGISTER (PECCR)

The Power, Enable, Calibration, and Configuration Register is illustrated in [Table 9](#). A write to the 33977 using this register allows the master to:

- Enable or disable the output drivers of the gauge controller
- Calibrate the internal clock
- Disable the air core emulation
- Select the direction of the pointer movement during pointer positioning and zeroing
- Configure the device for the desired status information to be clocked out into the SO pin, or
- Send a null command for the purpose of reading the status bits.

This register is also used to place the 33977 into a low current consumption mode.

The gauge drivers can be enabled by writing Logic [1] to the assigned address bits, PE0. This feature could be used to disable a driver if it is failing. The device can be placed into a standby current mode by writing Logic [0] to PE0. During this state, most current consuming circuits are biased off. When in the Standby mode, the internal clock will remain ON.

The internal state machine utilizes a ROM table of step times defining the duration that the motor will spend at each microstep as it accelerates or decelerates to a commanded position. The accuracy of the acceleration and velocity of the motor is directly related to the accuracy of the internal clock. Although the accuracy of the internal clock is temperature independent, the non-calibrated tolerance is +70% to -35%. The 33977 was designed with a feature allowing the internal clock to be software calibrated to a tighter tolerance of ±10%, using the  $\overline{CS}$  pin and a reference time pulse provided by the microcontroller.

Calibration of the internal clock is initiated by writing Logic [1] to PE3. The calibration pulse, which must be 8.0  $\mu$ s for an internal clock speed of 1.0 MHz, will be sent on the  $\overline{CS}$  pin immediately after the SPI word is sent. No other SPI lines will be toggled. A clock calibration will be allowed only if the gauge is disabled or the pointer is not moving, as indicated

by status bits MOV0. Additional details are provided in the [Internal clock Calibration](#) section.

Some applications may require a guaranteed maximum pointer velocity and acceleration. Guaranteeing these fall below 1.0 MHz. The frequency range of the calibrated clock maximums requires [that deleted PV] the nominal internal clock frequency will always be below 1.0 MHz if bit PE4 is Logic [0] when initiating a calibration command, followed by an 8.0 μs reference pulse. The frequency will be centered at 1.0 MHz if bit PE4 is Logic [1]. Some applications may require a slower calibrated clock due to a lower motor gear reduction ratio. Writing Logic [1] to bit PE2 will slow the internal oscillator by one-third. Slowing the oscillator accommodates a longer calibration pulse without overrunning the internal counter - a condition designed to generate a CAL fault indication. For example, calibration for a clock frequency of 667 kHz would require a calibration pulse of 12 μs. Unless the internal oscillator is slowed by writing PE2 to Logic [1], a 12 μs calibration pulse may overrun the counter and generate a CAL fault indication.

Some applications may require faster pointer positioning than is provided with the air core motor emulation feature. Writing Logic [1] to bit PE5 will disable the air core emulation for both gauges and provide an acceleration and deceleration at the maximum that the velocity position ramp can provide. Bit PE6 must always be written Logic [0] during all PECCR writes if the device is being used to drive an MMT style motor.

Similarly, this bit must always be written as Logic [1] when being used to control Switec style motors.

The default Pointer Position 0 (PE7 = 0) will be the farthest counter-clockwise position. A Logic [1] written to bit PE7 will change the location of the position 0 for the gauge to the farthest clockwise position. The pointer will always move towards position 0 when executing an RTZ. Exercise care when writing to PECCR bit PE7 in order to prevent an accidental change of the position 0 location.

Bits PE11:PE9 determine the content of the bits clocked out of the SO pin. When bit PE11 is at Logic [0], the clocked out bits will provide device status. If Logic [1] is written to bit PE11, the bits clocked out of the SO pin, depending upon the state of bits PE10:PE9, provides either:

- Accumulator information and detection status during the RTZ (PE10 Logic [0])
- Real time pointer position location at the time cs goes low (PE10 Logic [1] and PE9 Logic [0]), or
- The real time step position of the pointer as described in the velocity [Table 6](#) (PE10 and PE9 Logic [1]).

Additional details are provided in the [SO Communication](#) section.

If bit PE12 is Logic [1] during a PECCR command, the state of PE11:PE0 is ignored. This is referred to as the null command and can be used to read device status without affecting device operation.

**Table 9. Power, Enable, Calibration, and Configuration Register (PECCR)**

Address 000													
Bits	D12	D11	D10	D9	D8	D7	D6	D5	D4	D3	D2	D1	D0
Read	-	-	-	-	-	-	-	-	-	-	-	-	-
Write	PE12	PE11	PE10	PE9	0	PE7	PE6	PE5	PE4	PE3	PE2	0	PE0

The bits in [Table 9](#) are *write-only*.

**Null Command for Status Read (PE12) Bit D12**

- 0 = Disable
- 1 = Enable

**Status Select (PE11) Bit D11**

This bit selects the information clocked out of the SO pin.

- 0 = Device Status (the logic states of PE10, and PE9 are don't cares)
- 1 = RTZ Accumulator Value, Gauge Pointer position, or Gauge Velocity ramp position (depending upon the logic states of PE10, and PE9)

**RTZ Accumulator or Pointer Status Select (PE10) Bit D10**

This bit is recognized only when PE11 = 1.

- 0 = RTZ Accumulator Value and status
- 1 = Pointer Position or Speed

**Pointer Position or Pointer Speed Select (PE9) Bit D9**

This bit is recognized only if PE11 and PE10 = 1.

- 0 = Gauge Pointer Position
- 1 = Gauge Pointer Speed

**(PE8) Bit D8**

This bit must be transmitted as Logic [0] for valid PECCR commands.

**Position 0 Location Select (PE7) Bit D7**

This bit determines the Position 0 of the gauge. RTZ direction will always be to the position 0.

- 0 = Position 0 is the most CCW (counterclockwise) position
- 1 = Position 0 is the most CW (clockwise) position

**Motor Type Selection (PE6) Bit D6**

- 0 = MMT Style (coil phase difference = 90°)
- 1 = Switec Style (coil phase difference = 60°)

### Air Core Motor Emulation (PE5) Bit D5

This bit is enabled or disabled (acceleration and deceleration is constant if disabled).

- 0 = Enable
- 1 = Disable

### Clock Calibration Frequency Selector (PE4) Bit D4

- 0 = Maximum  $f = 1.0$  MHz (for  $8.0 \mu\text{s}$  calibration pulse)
- 1 = Nominal  $f = 1.0$  MHz (for  $8.0 \mu\text{s}$  calibration pulse)

### Clock Calibration Enable (PE3) Bit D3

This bit enables or disables the clock calibration.

- 0 = Disable
- 1 = Enable

### Oscillator Adjustment (PE2) Bit D2

- 0 =  $t_{\text{CLU}}$
- 1 =  $0.66 \times t_{\text{CLU}}$

### (PE1) Bit D1

This bit must be transmitted as Logic [0] for valid PECCR commands

### Gauge Enable (PE0) Bit D0

This bit enables or disables the output drivers of the Gauge.

- 0 = Disable
- 1 = Enable

### ADDRESS 001 - MAXIMUM VELOCITY REGISTER (VELR)

The Gauge Maximum Velocity Register is used to set a maximum velocity for the gauge (refer to [Table 4](#)). Bits V7:V0 contain a position value from 1 - 225 representative of the velocity position value described in the Velocity Table, [Table 6](#). The table value becomes the maximum velocity until it is changed to another value. If a maximum value is chosen that is greater than the maximum velocity of the acceleration table, the maximum table value becomes the maximum velocity.

If the motor is turning at a speed greater than the new maximum, the motor immediately moves down the velocity ramp until the speed falls equal to or below it. Bit V8 must be written to a Logic [1] when changing the maximum velocity of the motor. Bits V12:V10 must be at Logic [0] for valid VELR commands.

**Table 10. Maximum Velocity Register (VELR)**

Address 001													
Bits	D12	D11	D10	D9	D8	D7	D6	D5	D4	D3	D2	D1	D0
Read	–	–	–	–	–	–	–	–	–	–	–	–	–
Write	0	0	0	0	V8	V7	V6	V5	V4	V3	V2	V1	V0

The bits in [Table 10](#) are *write-only*.

### (V12:V9) Bits D12:D9

These bits must be transmitted as Logic [0] for valid VELR commands.

### Gauge Velocity (V8) Bit D8

Enables the maximum velocity as determined in the V7:V0.

- 0 = Velocity change disabled
- 1 = Velocity change enabled

### (V7:V0) Bits D7:D0

These bits can be used to program the device to limit the maximum velocity of the pointer movement. to one of over 200 speeds listed in the Velocity [Table 6](#). This velocity will remain the maximum of the intended gauge until changed by command. Velocities can range from position 1 (00000001) to position 225 (11111111).

### ADDRESSES 010 - GAUGE POSITION REGISTER (POSR)

SI Address 010 (Gauge Position Register) register bits PO11:PO0 are written to when communicating the desired pointer positions. Commanded positions can range from 0 to 4095

**Table 11. Gauge Position Register (POSR)**

Address 010													
Bits	D12	D11	D10	D9	D8	D7	D6	D5	D4	D3	D2	D1	D0
Read	–	–	–	–	–	–	–	–	–	–	–	–	–
Write	0	P011	P010	P09	P08	P07	P06	P05	P04	P03	P02	P01	P00

The bits in [Table 11](#) are *write-only*.



**PO012 (D12)**

This bits must be transmitted as Logic [0] for valid POSR commands.

**P011:P00 (D11:D0)**

Desired pointer position of Gauge. Pointer positions can range from 0 (000000000000) to position 4095 (111111111111). For a stepper motor requiring 12 microsteps per degree of pointer movement, the maximum pointer sweep is 341.25° (4095 ÷ 12).

**ADDRESS 100 - GAUGE RETURN TO ZERO REGISTER (RTZR)**

Gauge Return to Zero Register (RTZR), [Table 12](#) below, is written to return the gauge pointers to the zero position. During an RTZ event, the pointer is returned to zero using full

**Table 12. Gauge Return to Zero Register (RTZR)**

Address 100													
Bits	D12	D11	D10	D9	D8	D7	D6	D5	D4	D3	D2	D1	D0
Read	–	–	–	–	–	–	–	–	–	–	–	–	–
Write	0	0	0	0	0	0	0	0	RZ4	0	RZ2	RZ1	0

The register bits in [Table 12](#) are *write-only*.

**(RZ12:RZ5) Bits D12:D5**

These bits must be transmitted as Logic [0] for valid commands.

**(RZ4) Bit D4**

This bit is used to enable an unconditional RTZ event.

- 0 = Automatic Return to Zero
- 1 = Unconditional Return to Zero

**(RZ3) Bit D3**

This bit must be transmitted as Logic [0] for valid commands.

**(RZ2) Bit D2**

Return to Zero Direction bit. This bit is used to properly sequence the integrator, depending upon the desired zeroing direction.

- 0 = Return to Zero will occur in the CCW direction (PE7 = 0)
- 1 = Return to Zero will occur in the CW direction (PE7 = 1)

**(RZ1) Bit D1**

Return to Zero Enable. This bit commands the gauge to return the pointer to zero position.

- 0 = Return to Zero Disabled
- 1 = Return to Zero Enabled

steps, where only one coil is driven at any point in time. The back electromotive force (EMF) signal present on the non-driven coil is integrated and its results are stored in an accumulator. A Logic [1] written to bit RZ1 enables a Return to Zero for the Gauge if RZ0 is Logic [0]. A Logic [0] written to bit RZ1 disables a Return to Zero for the Gauge when RZ0 is Logic [0].

Bits D12:D5 and D3:D2 must be written Logic [0] for valid RTZR commands. An unconditional RTZ event can be enabled or disabled with Bit RZ4. Writing Logic [0] results in a typical RTZ event, automatically providing a Stop when a stall condition is detected. A Logic [1] will result in RTZ movement, causing a Stop if a Logic [0] is written to bit RZ0. This feature is useful during development and characterization of RTZ requirements.

**(RZ0) Bit D0**

Return to Zero Enable. This bit must always be written Logic [0].

**ADDRESS 101 - GAUGE RETURN TO ZERO CONFIGURATION REGISTER**

Gauge Return to Zero Configuration Register (RTZCR) is used to configure the Return to Zero Event, [Table 13](#). It is written to modify the: [listed as bullets for reading ease]

- Step time, or rate at which the pointer moves during an RTZ event
- Integration blanking time, which is the time immediately following the transition of a coil from a driven state to an open state in the RTZ mode
- Threshold of the RTZ integration register

Values used for this register should be selected during development to optimize the RTZ for each application. Selecting an RTZ step rate resulting in consistently successful zero detections depends on a clear understanding of the motor characteristics. Specifically, resonant frequencies exist due to the interaction between the motor and the pointer. This command allows for the selection of an RTZ pointer speed away from these frequencies. Also, some motors require a significant amount of time for the pointer to settle to a steady state position when moving from one full step position to the next. Consistent and accurate integration values require that the pointer be stationary at the end of the full step time.

Bits RC3:RC0, RC12:RC11, and RC4 determine the time spent at each full step during an RTZ event. Bits RC3:RC0 are used to select a Δt ranging from 0 ms (0000) to 61.44 ms

(1111) in increments of 4.096 ms (refer to [Table 14](#)). The  $\Delta t$  is multiplied by the factor M, defined by bits RC12:RC11. The product is then added to the blanking time, selected using bit RC4, to generate the full step time. The multiplier selected with RC12:RC11 will be 1 (00), 2 (01), or 4 (10) as illustrated in the equations below. Note that the RC12:RC11 value of 8 (11) is not recommended for use in a product design application, because of the potential for an RTZ accumulator internal overflow, due to the long time step. The blanking time is either 512  $\mu$ s when RC4 is Logic [0], or 768  $\mu$ s when it is Logic [1]. The full step time is calculated using the following equations:

When D3:D0 (RC3:RC0) = 0000

$$\text{Full Step (t)} = \Delta t \times M + \text{blanking (t)} \quad (1)$$

When D3:D0 (RC3:RC0) = 0000

$$\text{Full Step (t)} = \text{blanking (t)} + 2.048 \text{ ms} \quad (2)$$

**Note:** In equation (2), a 2.048 ms offset is added to the full step time when the RC3:RC0 = 0000. The full step time default value after a logic reset is 12.80 ms (RC12:RC11 = 00, RC4 = 0, and RC3:RC0 = 0011).

If there are two full steps per degree of pointer movement, the pointer speed is  $1/(\text{Full Step} \times 2)$  deg/s.

Detecting pointer movement is accomplished by integrating the EMF present in the non-driven coil during the RTZ event. The integration circuitry is implemented using a Sigma-Delta converter resulting in the placement of a value in the 15-bit RTZ accumulator at the end of each full step. The value in the RTZ accumulator represents the change in flux

**Table 13. Return to Zero Register Configuration Register (RTZCR)**

Address 101													
Bits	D12	D11	D10	D9	D8	D7	D6	D5	D4	D3	D2	D1	D0
Read	–	–	–	–	–	–	–	–	–	–	–	–	–
Write	RC12	RC11	RC10	RC9	RC8	RC7	RC6	RC5	RC4	RC3	RC2	RC1	RC0

The bits in [Table 13](#) are *write-only*.

**(RC12:RC11) Bits D12:D11**

These bits, along with RC3:RC0 (D3:D0) and RC4 (D4), determine the full step time and, therefore, the rate at which the pointer will move during an RTZ event. The values of D12:D11 determine the multiplier (M) used in equation (1) (refer to the previous page).

RC12:RC11 = M; default value = 00

- 00 = 1
- 01 = 2
- 10 = 4
- 11 = 8 (Not to be used for design)

**(RC10:RC5) Bits D10:D5**

These bits determine the value preloaded into the RTZ integration accumulator to adjust the detection threshold.

and is compared to a threshold. Values above the threshold indicate a pointer is moving. Values below the threshold indicate a stalled pointer, thereby resulting in the cessation of the RTZ event.

The RTZ accumulator bits are signed and represented in two's complement. After a full step of integration, a sign bit of 0 is the indicator of an accumulator exceeding the decision threshold of 0, and the pointer is assumed to still be moving. Similarly, if the sign bit is Logic [1] after a full step of integration, the accumulator value is negative and the pointer is assumed to be stopped. The integrator and accumulator are initialized after each full step. If the PECCR command is written to clock out the RTZ accumulator values via the SO, the OD14 bit corresponds to the sign bit of the RTZ accumulator.

Accurate pointer stall detection depends on a correctly preloaded accumulator for specific gauge, pointer, and full step combinations. Bits RC10:RC5 are used to offset the initial RTZ accumulator value, properly detecting a stalled motor. The initial accumulator value at the start of a full step of integration is negative. If the accumulator was correctly preloaded, a free moving pointer will result in a positive value at the end of the integration time, and a stalled pointer will result in a negative value. The preloaded values associated with each combination of bits RC10:RC5 are illustrated in [Table 15](#). The accumulator should be loaded with a value resulting in an accumulator MSB to Logic [1] when the motor is stalled. For the default mode, after a power-up or any reset, the 33977 device sets the accumulator value to -1.

Values range from -1 (00000000) to -1009 (11111111) as shown in [Table 15](#), the default value = 000000.

**(RC4) Bit D4**

This bit determines the RTZ blanking time (*blanking (t)*). The default value = 0

- 0 = 512  $\mu$ s
- 1 = 768  $\mu$ s

**(RC3:RC0) Bits D3:D0**

These bits, along with RC12:RC11 (D12:D11) and RC4 (D4), determine the time variables used to calculate the full step times with equations (1) or (2) illustrated above. RC3:RC0 determines the  $\Delta t$  time. The  $\Delta t$  values range from 0 (0000) to 61.440 ms (1111) and are shown in [Table 14](#). The default  $\Delta t$  is 0 (0011).

**Note:** Equation (2) (refer to the preceding page) is only used to calculate the full step time if RC3:RC0 = 0000. Use equation (1) for all other combinations of RC3:RC0.

**Table 14. RTZCR Full Step Time**

RC3	RC2	RC1	RC0	$\Delta t$ (ms)
0	0	0	0	0.0
0	0	0	1	4.096
0	0	1	0	8.192
0	0	1	1	12.288
0	1	0	0	16.384
0	1	0	1	20.480
0	1	1	0	24.576
0	1	1	1	28.672

**Table 14. RTZCR Full Step Time**

1	0	0	0	32.768
1	0	0	1	36.864
1	0	1	0	40.960
1	0	1	1	45.056
1	1	0	0	49.152
1	1	0	1	53.248
1	1	1	0	57.344
1	1	1	1	61.440

**Table 15. RTZCR Accumulator Offset**

RC10	RC9	RC8	RC7	RC6	RC5	Preload Value	Initial Accumulator Value = (-16xPV) -1
0	0	0	0	0	0	0	-1
0	0	0	0	0	1	1	-17
0	0	0	0	1	0	2	-33
0	0	0	0	1	1	3	-49
0	0	0	1	0	0	4	-65
.	.	.	.	.	.	.	.
.	.	.	.	.	.	.	.
.	.	.	.	.	.	.	.
1	1	1	1	1	1	63	-1009

ARCHIVE INFORMATION

ARCHIVE INFORMATION

## SO COMMUNICATION

When the  $\overline{CS}$  pin is pulled low, the internal status register, as configured with the PECCR command bits PE11:PE8, is loaded into the output register and the data is clocked out MSB (OD15) first. Following a  $\overline{CS}$  transition 0 to 1, the device determines if the shifted-in message was of a valid length (a valid message length is one that is greater than 0 bits and a multiple of 16 bits) and, if so, latches the incoming data into the appropriate registers. At this time, the SO pin is tri-stated and the status register is now able to accept new status information. Fault status information will be latched and held until the Device Status Output register is selected and it is clocked out via the SO. If the message length was determined to be invalid, the fault information will not be cleared and will be transmitted again during the next valid SPI message. Pointer status information bits (e.g., pointer position, velocity, and commanded position status) will always reflect the real time state of the pointer. Any bits clocked out of the SO pin after the first 16 are representative of the initial message bits clocked into the SI pin since the  $\overline{CS}$  pin first transitioned to a Logic [0]. This feature is useful for daisy-chaining devices as well as message verification. As described above, the last valid write to bits PE11:PE8 of the

PECCR command determines the nature of the status data that is clocked out of the SO pin. There are four different types of status information available:

1. Device Status ([Table 16](#))
2. RTZ Accumulator Status ([Table 17](#))
3. Gauge Pointer Position Status ([Table 18](#))
4. Gauge Pointer Velocity Status ([Table 19](#))

Once a specific status type is selected, it will not change until either the PECCR command bits PE11:PE8 (D11:D8) are written to select another or the device is reset. Each of the Status types and the PECCR bit necessary to select them are described in the following paragraphs.

## DEVICE STATUS INFORMATION

Most recent valid PECCR command resulting in the Device Status output:

D11	D10	D9	D8
0	x	x	x

x = Don't Care

**Table 16. Device Status Output Register**

Bits	OD15	OD14	OD13	OD12	OD11	OD10	OD9	OD8	OD7	OD6	OD5	OD4	OD3	OD2	OD1	OD0
Read	ST15	DIR	ST13	0POS	ST11	CMD	OV	UV	CAL	OVUV	ST5	MOV	ST3	RTZ	ST1	OT
Write	-	-	-	-	-	-	-	-	-	-	-	-	-	-	-	-

The bits in [Table 16](#) are *read-only* bits.

### (ST15) Bit OD15

This bit has no meaning.

### (DIR) Bit OD14

This bit indicates the direction that the Gauge is moving.

- 0 = Toward position 0
- 1 = Away from position 0

### (ST13) Bit OD13

This bit has no meaning.

### (0POS) Bit OD12

This bit indicates the configured Position 0 for the Gauge.

- 0 = Farthest CCW
- 1 = Farthest CW

### (ST11) Bit OD11

This bit has no meaning.

### (CMD) Bit OD10

This bit indicates if the Gauge is at the most recently commanded position.

- 0 = At commanded position
- 1 = Not at commanded position

### Overvoltage Indication (OV) Bit OD9

A Logic [1] on this bit indicates  $V_{PWR}$  voltage exceeded the upper limit of  $V_{PWROV}$  since the last SPI communication. Refer to the Static Electrical Characteristics [Table 3](#) under POWER INPUT.

An overvoltage event will automatically disable the driver outputs. Because the pointer may not be in the expected position, the master may want to re-calibrate the pointer position with an RTZ command after the voltage returns to a normal level. For an overvoltage event, both gauges must be re-enabled as quickly as this flag returns to Logic [0]. The state machine will continue to operate properly as long as  $V_{DD}$  is within the normal range.

- 0 = Normal range
- 1 = Battery voltage exceeded  $V_{PWROV}$

### Undervoltage Indication (UV) Bit OD8

A Logic [1] on this bit indicates the  $V_{PWR}$  voltage fell below  $V_{PWRUV}$  since the last SPI communication. Refer to the *Static Electrical Characteristics* [Table 3](#) under the heading of POWER INPUT. An undervoltage event is just flagged; however, at some voltage level below 4.0 V, the outputs turn OFF and the state machine resets. Because the pointer may

not be in the expected position, the master may want to re-calibrate the pointer position with an RTZ command after the voltage returns to a normal level. For an undervoltage vent, both gauges may need to be re-enabled as quickly as this flag returns to Logic [0]. The state machine will continue to operate properly as long as  $V_{DD}$  is within the normal range.

- 0 = Normal range
- 1 = Battery voltage fell below  $V_{PWRUV}$

**Calibrated Clock out of Specification (CAL) Bit OD7**

Reading Logic [1] on this bit indicates the clock count calibrated to a value outside the expected range given the tolerance specified by  $t_{CLC}$  in the Dynamic Electrical Characteristics **Table 4** under POWER OUTPUT and CLOCK TIMING.

- 0 = Clock within specification
- 1 = Clock out of specification

**Undervoltage or Overvoltage Indication (OVUV) Bit OD6**

A Logic [1] on this bit indicates  $V_{PWR}$  voltage fell to a level below the  $V_{PWRUV}$  since the last SPI communication. Refer to the Static Electrical Characteristics table, **Table 3** under the subheading INPUT POWER. An undervoltage event is just flagged, while an overvoltage event automatically disables the drive outputs. Because the pointer may not be in the expected position, the master may want to re-calibrate the pointer with an RTZ command after the voltage returns to normal level. For an overvoltage event, both gauges must be re-enabled as soon as this flag returns to Logic [0]. The state machine will continue to operate properly as long as  $V_{DD}$  is within the normal range.

- 0 = Normal range
- 1 = Battery voltage fell below  $V_{PWRUV}$  or exceeded  $V_{PWROV}$

**(ST5) Bit OD5**

This bit has no meaning

**Gauge Movement Since last SPI Communication (MOV) Bit OD4**

A Logic [1] on this bit indicates the Gauge pointer position has changed since the last SPI command. This information allows the master to confirm the pointer is moving as commanded.

This bit may also be used to determine if the Gauge is enabled or disabled.

- 0 = Gauge position has not changed since the last SPI command
- 1 = Gauge pointer position has changed since the last SPI command

**ST3 (OD3) - This bit has no meaning**

**RTZ0 Is Enabled or Disabled (RTZ) Bit OD2**

A Logic [1] on this bit indicates the gauge is in the process of returning to the zero position as requested with the RTZ command. This bit continues to indicate Logic [1] until the SPI message following a detection of the zero position, or the RTZ feature is commanded OFF using the RTZ message.

- 0 = Return to Zero disabled
- 1 = Return to Zero enabled successfully

**(ST1) Bit OD1**

This bit has no meaning.

**Gauge Driver Junction Overtemperature (OT) Bit OD0**

A Logic [1] on this bit indicates that the coil drive circuitry has exceeded the maximum allowable junction temperature since the last SPI communication and that the Gauge has been disabled. It is recommended that the pointer be re-calibrated using the RTZ command after re-enabling the gauge using the PECCR command. This bit remains Logic [1] until the gauge is re-enabled.

- 0 = Temperature within range
- 1 = Maximum allowable junction temperature condition is reached

**RTZ ACCUMULATOR STATUS INFORMATION**

Most recent valid PECCR command resulting in the RTZ Accumulator status output:

D11	D10	D9	D8
1	0	x	x

x = Don't Care

[Used headings to distinguish bits and accompanying text.]

**Table 17. RTZ Accumulator Status Output Register**

Bits	OD15	OD14	OD13	OD12	OD11	OD10	OD9	OD8	OD7	OD6	OD5	OD4	OD3	OD2	OD1	OD0
Read	RTZ	ACC14	ACC13	ACC12	ACC11	ACC10	ACC9	ACC8	ACC7	ACC6	ACC5	ACC4	ACC3	ACC2	ACC1	ACC0
Write	-	-	-	-	-	-	-	-	-	-	-	-	-	-	-	-

The bits in **Table 17** are *read-only* bits.

**(RTZ) Bit OD15**

RTZ Bit Is Enabled or Disabled. Reading Logic [1] on this bit indicates that the Gauge is in the process of returning to the zero position as requested with the RTZ command. This

bit will continue to indicate Logic [1] until the SPI message following a detection of the zero position, or after the RTZ feature is commanded OFF using the RTZ message.

- 0 = Return to Zero disabled
- 1 = Return to Zero enabled successfully

[Corrected original entry above to ACC2]

#### (ACC14:ACC0) Bits OD14:OD0

These 15 bits are from the RTZ accumulator. They represent the integrated signal present on the non-driven coil during an RTZ event. These bits are Logic [0] after power-on reset, or after the RST pin transitions from Logic [0] to [1]. After an RTZ event, they will represent the last RTZ accumulator result before the RTZ was stopped.

ACC14 is the MSB and is the sign bit used for zero detection. Negative numbers have MSB Logic [1] and are coded in twos complement.

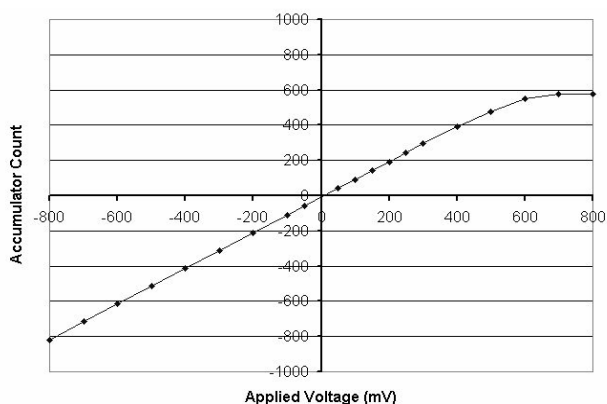

Figure 13. RTZ Accumulator (Typical)

Table 18. Gauge Pointer Position Status Output Register

Bits	OD15	OD14	OD13	OD12	OD11	OD10	OD9	OD8	OD7	OD6	OD5	OD4	OD3	OD2	OD1	OD0
Read	ENB	DIR	DIRC	CMD	POS11	POS10	POS9	POS8	POS7	POS5	POS5	POS4	POS3	POS2	POS1	POS0
Write	-	-	-	-	-	-	-	-	-	-	-	-	-	-	-	-

The bits in Table 18 are read-only bits.

#### (ENB) Bit OD15

This bit indicates whether the Gauge is enabled.

- 0 = Disabled
- 1 = Enabled

#### (DIR) Bit OD14

This bit indicates the direction the Gauge is moving.

- 0 = Toward position 0
- 1 = Away from position 0

The analog-to-digital converter's linear input range covers the expected magnitude of motor back e.m.f. signals, which is usually less than 500mV. Input signals greater than this will not cause any damage (the circuit is connected to the motor H-Bridge drivers, and thus is exposed to the full magnitude of the drive voltages), but may cause some small loss of linearity. A typical plot of output vs. input is shown in Figure 13 for 4ms step times.

#### GAUGE POINTER POSITION STATUS INFORMATION

Most recent valid PECCR command resulting in the Gauge Pointer Position status output:

D11	D10	D9	D8
1	1	0	0

omitted "don't care--because N/A

#### (DIRC) Bit OD13

This bit is used to determine whether the direction of the most recent pointer movement is toward the last commanded position or away from it.

- 0 = Direction of the pointer movement is toward the commanded position
- 1 = Direction of the pointer movement is away from the commanded position

#### (CMD) Bit OD12

This bit indicates whether the gauge is at the most recently commanded position.

- 0 = At commanded position
- 1 = Not at commanded position



**(POS11:POS0) Bits OD11:OD0**

These 12 bits represent the actual position of the pointer at the time CS transitions to a Logic [0].

<b>D11</b>	<b>D10</b>	<b>D9</b>	<b>D8</b>
1	1	1	x

x = Don't Care

**GAUGE POINTER VELOCITY STATUS INFORMATION**

Most recent valid PECCR command resulting in the Gauge and 1 Pointer Velocity status output:

**Table 19. Gauge Pointer Velocity SStatus Output Register**

Bits	OD15	OD14	OD13	OD12	OD11	OD10	OD9	OD8	OD7	OD6	OD5	OD4	OD3	OD2	OD1	OD0
Read	V15	V14	V13	V12	V11	V10	V9	V8	V7	V6	V5	V4	V3	V2	V1	V0
Write	-	-	-	-	-	-	-	-	-	-	-	-	-	-	-	-

The bits in Table 19 are *read-only* bits.

**(V15:V8) Bits OD15:OD8**

These eight bits have no meaning. Velocity position that identifies it in the un-truncated ramp (e.g., if RS = 2, then the velocity step location will be 3 when the pointer is at the commanded position).

**(V7:V0) Bits OD7:OD0**

These eight bits represent the step table value, [that deleted PV] indicating the actual velocity step location (refer to [Table 19](#)) of the Gauge pointer at the time that the CS transitions to a Logic [0].

ARCHIVE INFORMATION

ARCHIVE INFORMATION

## TYPICAL APPLICATIONS

The 33977 is an extremely versatile device that can be used in a variety of applications. [Figure 1](#). The acceleration and deceleration ramps have been designed for applications where smooth movement is of the highest priority. These ramps are fixed and the characteristics can be seen in the

following figures. For applications where configurable pointer response and damping are desirable, consider the features of the MC33976. [Figure 14](#) shows the characteristics of the acceleration ramp.

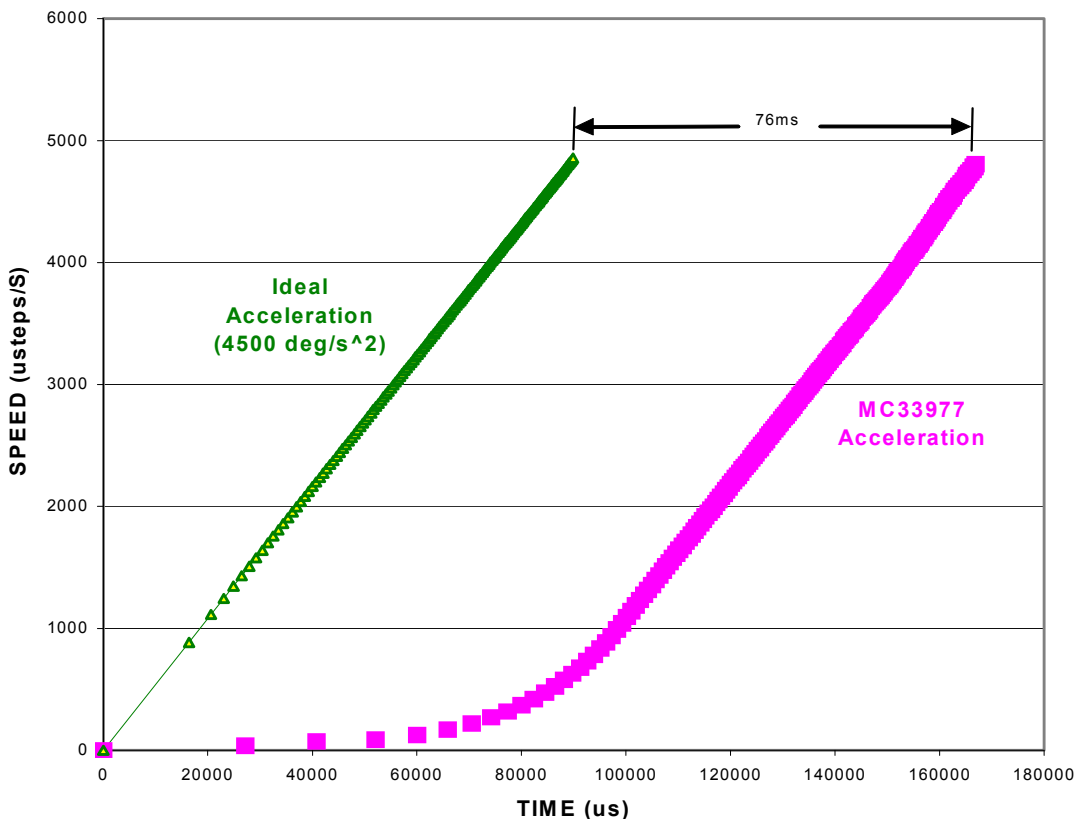

Figure 14. Acceleration Response Characteristics



Figure 15 illustrates the deceleration damping characteristics of the device with the hold counts enabled and disabled.

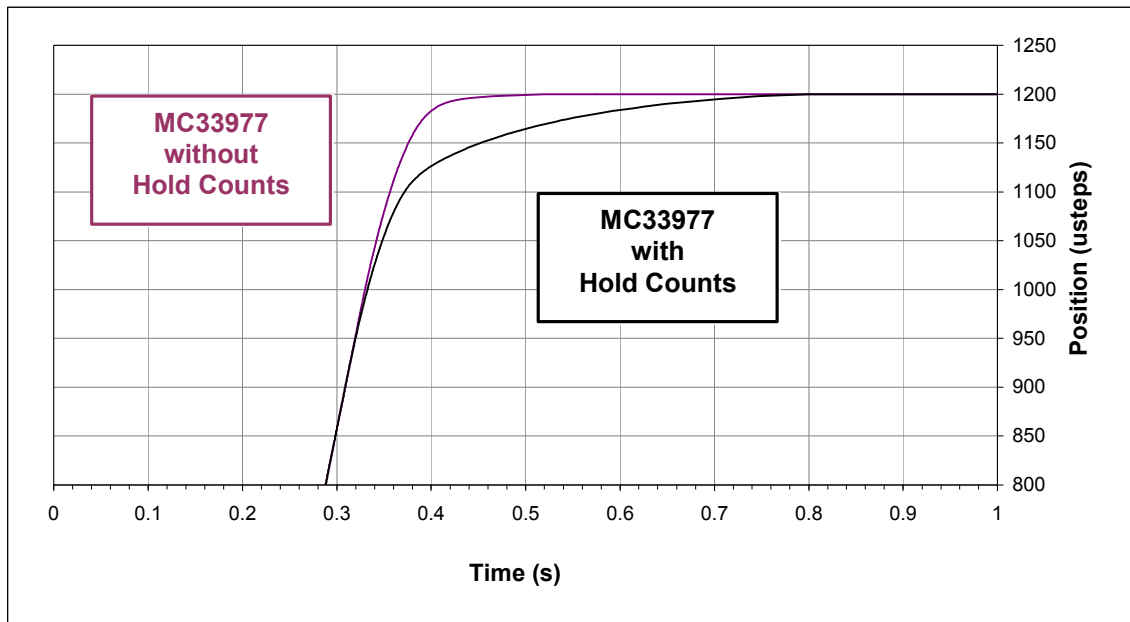

Figure 15. Deceleration Damping Response Examples

Table 20 provides a step-by-step example of configuring and using many of the features designed into the IC. This

example is intended to familiarize users with some of the device features.

Table 20. 33977 Setup, Configuration, and Usage Example

Step	Command	Description	Reference Table and/or Figure
1	PECCR	a) Enables the gauge <ul style="list-style-type: none"> <li>• Bit PE0: Gauge enable bit</li> </ul>	<a href="#">Table 9</a> , <a href="#">Figure 8</a>
		b) Clock calibration <ul style="list-style-type: none"> <li>• Bit PE3: Enables calibration procedure</li> <li>• Bit PE4: Set clock f = 1.0 MHz maximum or nominal</li> </ul>	
		c) Send 8.0 $\mu$ s pulse on CS to calibrate 1.0 MHz clock	
2	RTZCR	a) Set RTZ full step time <ul style="list-style-type: none"> <li>• Bit RC3:RC0</li> </ul>	<a href="#">Table 13</a> <a href="#">Table 14</a> <a href="#">Table 15</a> <a href="#">Table 9</a>  <a href="#">Table 16</a>
		b) Set RTZ blanking time <ul style="list-style-type: none"> <li>• Bits RC4</li> </ul>	
		c) Preload RTZ accumulator <ul style="list-style-type: none"> <li>• Bits RC12:RC11 and RC10:RC5</li> </ul>	
		d) Check SO for an out-of-range clock calibration <ul style="list-style-type: none"> <li>• Is Bit CAL Logic [1]? If so, repeat Steps 1 and 2</li> </ul>	
4	POSR	a) Move pointer to position 12 prior to RTZ	<a href="#">Table 11</a> <a href="#">Table 9</a> <a href="#">Table 16</a>
		b) Check SO to determine if gauge has moved <ul style="list-style-type: none"> <li>• Is bit MOV (OD4) Logic [1]? If so, the gauge moved to the first microstep</li> </ul>	
5	PECCR	a) Send null command to determine if gauges moved <ul style="list-style-type: none"> <li>• Bit PE12</li> </ul>	<a href="#">Table 9</a> <a href="#">Table 9</a> <a href="#">Table 16</a>
		b) Check SO to determine if the gauge has moved <ul style="list-style-type: none"> <li>• Is bit MOV (OD4) Logic [1]? If so, the gauge moved another microstep since the last SPI message. Keep track of movement and if 12 steps are finished, and both gauges are at a static position, the RTZ. Otherwise, repeat steps a) and b).</li> <li>• Bit CMD (OD10) could also be monitored to determine if the pointer is static.</li> </ul>	

**Table 20. 33977 Setup, Configuration, and Usage Example**

Step	Command	Description	Reference Table and/or Figure
6	RTZ	a) Return the gauge to the zero stop using the RTZ command <ul style="list-style-type: none"> <li>• Bit RZ1 enables or disables an RTZ</li> <li>• Bits RZ2 and PE7 select the direction</li> </ul>	<a href="#">Table 12</a> <a href="#">Table 9</a> <a href="#">Table 15</a>
		b) Select the RTZ accumulator bits to clock out on the SO bits using bits PE11:PE10. These will be used if characterizing the RTZ.	
7	PECCR	a) Check the status of the RTZ by sending the null command to monitor bit RTZ of the Device Status SO. <ul style="list-style-type: none"> <li>• Bit PE12 is the null command</li> </ul>	<a href="#">Table 9</a> <a href="#">Table 16</a>
		b) Is RTZ (OD2) Logic [1]? If not, the gauge is still returning and null command should be resent.	
10	VELR	a) Change the maximum velocity of the gauge <ul style="list-style-type: none"> <li>• Bit V8 enables a change to the maximum velocity</li> <li>• Bits V7:V10 determine the maximum velocity position from <a href="#">Table 6</a>, Velocity Table</li> </ul>	<a href="#">Table 9</a> <a href="#">Table 6</a>
11	POSR	a) Position gauge pointer <ul style="list-style-type: none"> <li>• Bits P011:P00: Desired pointer position</li> </ul>	<a href="#">Table 11</a> <a href="#">Table 6</a>
		b) Check SO for out-of-range $V_{PWR}$ <ul style="list-style-type: none"> <li>• Is bit OVUV (OD6) Logic [1]? If so, use UV (OD8) and OV (OD9) to decide whether to RTZ after valid <math>V_{PWR}</math></li> </ul>	
		c) Check SO for overtemperature <ul style="list-style-type: none"> <li>• Is bit OT Logic [1]? If so, enable driver again. If OT continues to indicate overtemperature, shut down the gauge.</li> <li>• Once OT returns to normal, re-establish the zero reference by RTZ command.</li> </ul>	
13	POSR	a) Return the pointer close to zero position using POSR	<a href="#">Table 11</a>
		b) Move pointer position at least 12 microsteps CW to the nearest full step prior to RTZ	
15	PECCR	f) Send null command to see if gauges moved <ul style="list-style-type: none"> <li>• Bit PE12</li> </ul> g) Check SO to determine if the gauge moved. <ul style="list-style-type: none"> <li>• Is bit MOV (OD4) Logic [1]? If so, the gauge moved another microstep since the last SPI message. Keep track of movement and if 12 steps are finished, and both gauges are at a static position, then RTZ. Otherwise, repeat steps a) and b).</li> <li>• Bit CMD (OD10) could also be monitored to determine the pointer is static.</li> </ul>	<a href="#">Table 9</a> <a href="#">Table 16</a>
16	RTZ	a) Return the gauge to the zero stop using the RTZ command. <ul style="list-style-type: none"> <li>• Bit RZ1 enables or disables an RTZ</li> <li>• Bits RZ2 and PE7 select the direction</li> </ul>	<a href="#">TABLE 9</a> <a href="#">TABLE 12</a> <a href="#">TABLE 16</a>
		b) Select the RTZ accumulator bits clocking out on the SO bits using bits PE11:PE10. These will be used if characterizing the RTZ.	
17	PECCR	a) Check the status of the RTZ by sending the null command to monitor SO bit RTZ <ul style="list-style-type: none"> <li>• Bit PE12 is the null command</li> </ul>	<a href="#">TABLE 9</a> <a href="#">TABLE 16</a>
		b) Is RTZ Logic [0]? If not, the gauge is still returning and null command should be resent	
20	PECCR	a) Disable the gauge driver and go to standby <ul style="list-style-type: none"> <li>• Bit PE0:PE1 disable the gauge</li> </ul>	<a href="#">TABLE 9</a>
		b) Put the device to sleep <ul style="list-style-type: none"> <li>• RST pin is pulled to Logic [0]</li> </ul>	

# PACKAGING

## PACKAGE DIMENSIONS

For the most current revision of the package, visit [www.freescale.com](http://www.freescale.com) and do a keyword search using the "98A" number listed below.

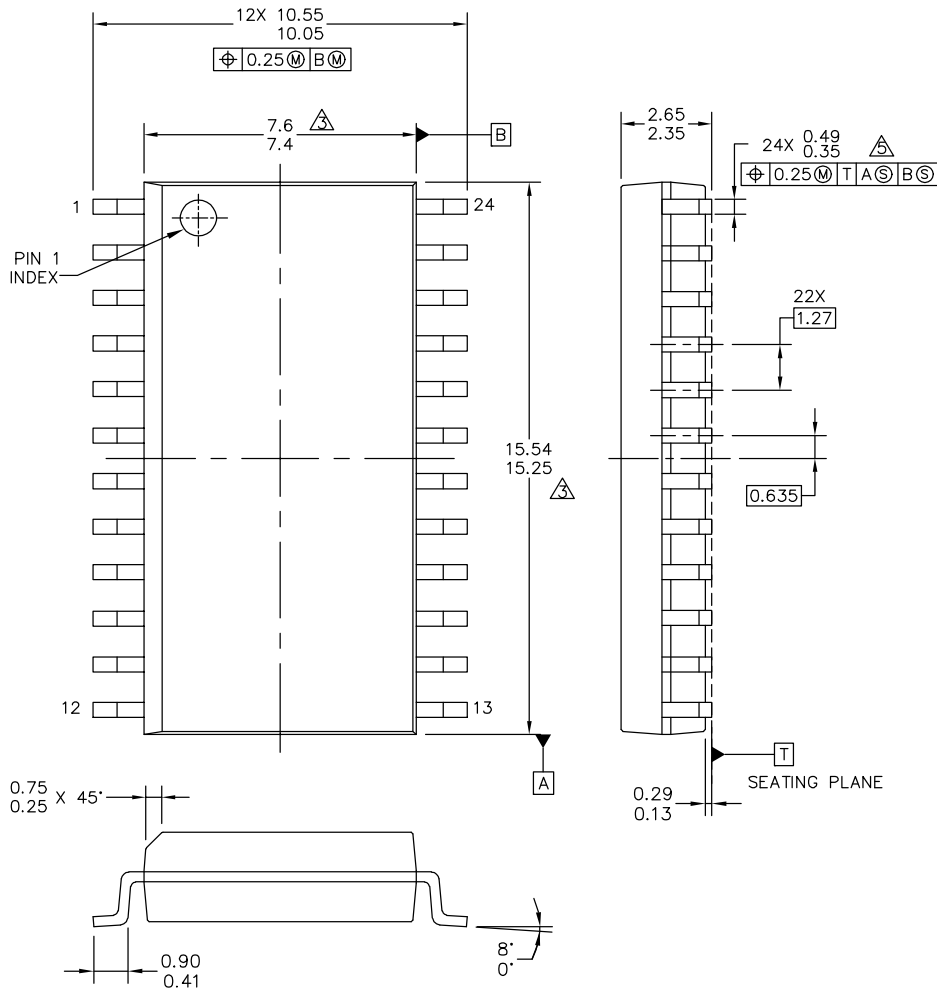

© FREESCALE SEMICONDUCTOR, INC. ALL RIGHTS RESERVED.	<b>MECHANICAL OUTLINE</b>	PRINT VERSION NOT TO SCALE	
TITLE: 24LD SOIC W/B, 1.27 PITCH 7.5 X 15.4 CASE-OUTLINE	DOCUMENT NO: 98ASB42344B	REV: F	
	CASE NUMBER: 751E-04	26 APR 2005	
	STANDARD: JEDEC MS-013 AD		

**DW SUFFIX**  
**EG SUFFIX (PB-FREE)**  
24-PIN  
PLASTIC PACKAGE  
98ASB42344B  
ISSUE F

ARCHIVE INFORMATION

ARCHIVE INFORMATION

## REVISION HISTORY

REVISION	DATE	DESCRIPTION OF CHANGES
1.0	8/2006	<ul style="list-style-type: none"> <li>Initial release</li> </ul>
2.0	1/2007	<ul style="list-style-type: none"> <li>Updated to the current Freescale format</li> <li>Revised <a href="#">Internal Block Diagram</a> to enhance readability</li> <li>Added parameter <a href="#">Peak Package Reflow Temperature During Reflow</a> <sup>(4)</sup>, <sup>(5)</sup> on page 4 and notes <sup>(4)</sup> and <sup>(5)</sup></li> <li>Made wording additions to <a href="#">Address 101 - Gauge Return to Zero Configuration Register on page 25</a> and <a href="#">(RC12:RC11) Bits D12:D11 on page 26</a></li> <li>Added <a href="#">ADC Gain</a> <sup>(12)</sup>, <sup>(14)</sup> to Static Electrical Characteristics table</li> <li>Added <a href="#">RTZ Accumulator (Typical) on page 30</a> and accompanying text</li> </ul>

ARCHIVE INFORMATION

ARCHIVE INFORMATION

**How to Reach Us:**

**Home Page:**  
[www.freescale.com](http://www.freescale.com)

**Web Support:**  
<http://www.freescale.com/support>

**USA/Europe or Locations Not Listed:**  
Freescale Semiconductor, Inc.  
Technical Information Center, EL516  
2100 East Elliot Road  
Tempe, Arizona 85284  
+1-800-521-6274 or +1-480-768-2130  
[www.freescale.com/support](http://www.freescale.com/support)

**Europe, Middle East, and Africa:**  
Freescale Halbleiter Deutschland GmbH  
Technical Information Center  
Schatzbogen 7  
81829 Muenchen, Germany  
+44 1296 380 456 (English)  
+46 8 52200080 (English)  
+49 89 92103 559 (German)  
+33 1 69 35 48 48 (French)  
[www.freescale.com/support](http://www.freescale.com/support)

**Japan:**  
Freescale Semiconductor Japan Ltd.  
Headquarters  
ARCO Tower 15F  
1-8-1, Shimo-Meguro, Meguro-ku,  
Tokyo 153-0064  
Japan  
0120 191014 or +81 3 5437 9125  
[support.japan@freescale.com](mailto:support.japan@freescale.com)

**Asia/Pacific:**  
Freescale Semiconductor Hong Kong Ltd.  
Technical Information Center  
2 Dai King Street  
Tai Po Industrial Estate  
Tai Po, N.T., Hong Kong  
+800 2666 8080  
[support.asia@freescale.com](mailto:support.asia@freescale.com)

**For Literature Requests Only:**  
Freescale Semiconductor Literature Distribution Center  
P.O. Box 5405  
Denver, Colorado 80217  
1-800-441-2447 or 303-675-2140  
Fax: 303-675-2150  
[LDCForFreescaleSemiconductor@hibbertgroup.com](mailto:LDCForFreescaleSemiconductor@hibbertgroup.com)

RoHS-compliant and/or Pb-free versions of Freescale products have the functionality and electrical characteristics of their non-RoHS-compliant and/or non-Pb-free counterparts. For further information, see <http://www.freescale.com> or contact your Freescale sales representative.

For information on Freescale's Environmental Products program, go to <http://www.freescale.com/epp>.

Information in this document is provided solely to enable system and software implementers to use Freescale Semiconductor products. There are no express or implied copyright licenses granted hereunder to design or fabricate any integrated circuits or integrated circuits based on the information in this document.

Freescale Semiconductor reserves the right to make changes without further notice to any products herein. Freescale Semiconductor makes no warranty, representation or guarantee regarding the suitability of its products for any particular purpose, nor does Freescale Semiconductor assume any liability arising out of the application or use of any product or circuit, and specifically disclaims any and all liability, including without limitation consequential or incidental damages. "Typical" parameters that may be provided in Freescale Semiconductor data sheets and/or specifications can and do vary in different applications and actual performance may vary over time. All operating parameters, including "Typicals", must be validated for each customer application by customer's technical experts. Freescale Semiconductor does not convey any license under its patent rights nor the rights of others. Freescale Semiconductor products are not designed, intended, or authorized for use as components in systems intended for surgical implant into the body, or other applications intended to support or sustain life, or for any other application in which the failure of the Freescale Semiconductor product could create a situation where personal injury or death may occur. Should Buyer purchase or use Freescale Semiconductor products for any such unintended or unauthorized application, Buyer shall indemnify and hold Freescale Semiconductor and its officers, employees, subsidiaries, affiliates, and distributors harmless against all claims, costs, damages, and expenses, and reasonable attorney fees arising out of, directly or indirectly, any claim of personal injury or death associated with such unintended or unauthorized use, even if such claim alleges that Freescale Semiconductor was negligent regarding the design or manufacture of the part.

Freescale™ and the Freescale logo are trademarks of Freescale Semiconductor, Inc. All other product or service names are the property of their respective owners.

© Freescale Semiconductor, Inc., 2007. All rights reserved.