

11925SA (4710SB)

DC Axial Fan Ball Bearing

119[□]X25^L



General Specifications

Motor Protection : Auto Restart / Polarity Protection
 Insulation Resistance : 10MΩ or over with a DC500V Megger
 Dielectric Withstand Voltage : AC700V 1s

Allowable Ambient Temperature Range : L, M, N Class : -10°C ~ +70°C (Operating)
 R Class : -10°C ~ +60°C
 (non-condensing environment) **All Classes : -40°C ~ +70°C (Storage)**

外観図 Outline

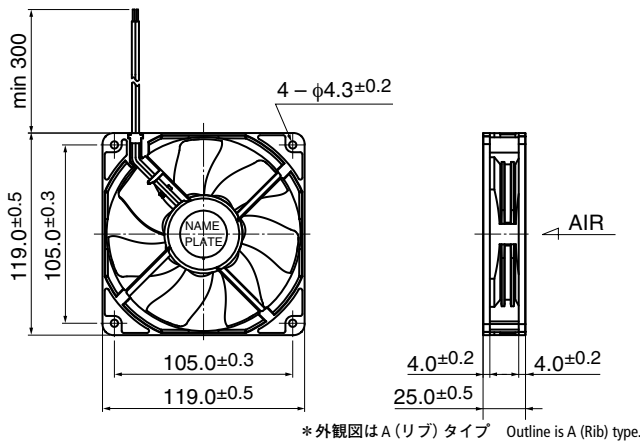

*外観図はA(リブ)タイプ Outline is A (Rib) type.

取付穴参考図 Panel Out-cuts

吸入側 (Inlet Side)

吐出側 (Outlet Side)

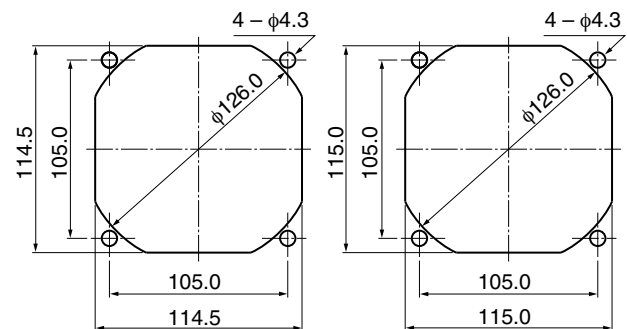

特性曲線 Characteristic Curves

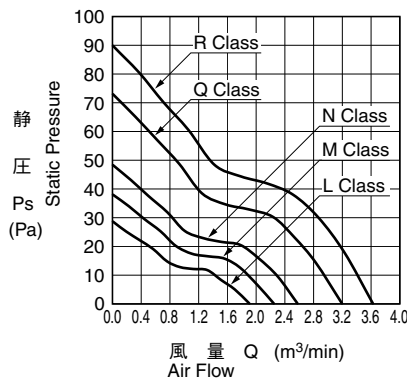

材質 Material

ケーシング : プラスチック(ブラック) UL94V-0
 インペラー : プラスチック(ブラック) UL94V-0
 軸受 : ボールベアリング
 リード線 : UL3385 AWG26 + : 赤 - : 黒

Casing : Plastic (Black) UL94V-0
 Impeller : Plastic (Black) UL94V-0
 Bearing : Ball Bearing
 Lead Wire : UL3385 AWG26 + : Red, - : Black

仕様 Specifications

□=ケーシング形状 Casing Form --- A : リブタイプ Rib Type、E : フランジタイプ Flange Type

型式 Model	管理番号 Product No.	定格電圧	使用電圧範囲	定格電流	定格入力	定格回転速度	最大風量		最大静圧		騒音	質量
		Rating Voltage (V)	Operating Voltage (V)	Current (A) ^{*1}	Input Power (W) ^{*1}	Speed (min ⁻¹) ^{*1}	Max. Air Flow (m ³ /min) ^{*1}	(CFM) ^{*1}	Max. Static Pressure (Pa) ^{*1}	(In H ₂ O) ^{*1}	Noise (dB) ^{*1}	Mass (g)
11925SA-12L-□AD-	0	12	7.0 ~ 13.8	0.13	1.56	1900	1.90	67.1	28.5	0.11	30.0	165
11925SA-12M-□AD-	0			0.16	1.92	2200	2.25	79.4	38.0	0.15	33.5	
11925SA-12N-□AD-	0			0.24	2.88	2500	2.58	91.1	48.0	0.19	37.0	
11925SA-12R-□AD-	0	24	12.0 ~ 27.6	0.62	7.44	3500	3.63	128.2	89.0	0.36	47.0	
11925SA-24L-□AD-	0			0.06	1.44	1900	1.90	67.1	28.5	0.11	30.0	
11925SA-24M-□AD-	0			0.08	1.92	2200	2.25	79.4	38.0	0.15	33.5	
11925SA-24N-□AD-	0	24	12.0 ~ 27.6	0.11	2.64	2500	2.58	91.1	48.0	0.19	37.0	
11925SA-24Q-□AD-	0			0.20	4.80	3100	3.20	113.0	73.0	0.29	44.0	

回転方向 : ラベルから見て時計方向 Rotation: Clockwise as seen from the label side
 風吹き出し方向 : ラベル側 Airflow Outlet: Label side

*1: Average Values in Free Air

General Specifications

Motor Type: DC Brushless Motor

Motor Protection: Auto Restart/Polarity Protection

Motor withstands reverse connection for positive and negative leads.

Insulation Resistance:

10M Ω or over with a DC500V Megger

Dielectric Withstand Voltage:

AC 700V 1s or 500V 1min

Allowable Ambient Temperature Range:

-10°C ~ +60°C (Operating)

-40°C ~ +70°C (Storage)

(non-condensing environment)

Characteristics Curves

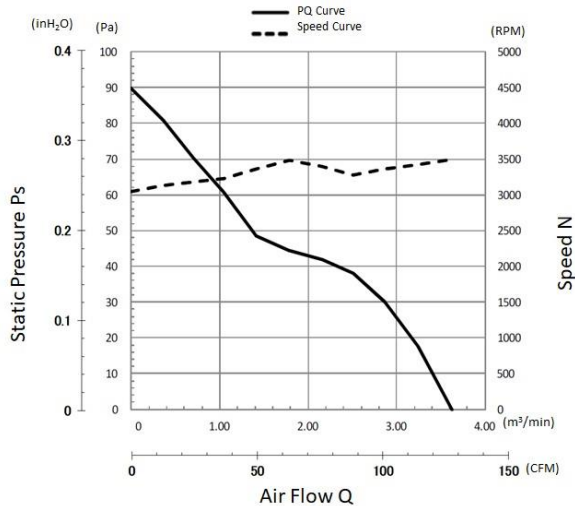

PWM Benefits & Applications

PWM Benefits

- Increased Life Expectancy
- Energy Saving
- Lower Vibration
- Lower Noise
- Current Spike Prevention

PWM Applications

- Routers
- Switches
- Storage
- Data Centers
- Optical Repeaters
- Broadcast Equipment
- Inverters
- UPS
- Battery Chargers
- Fuel Cells
- Industrial Power Supplies
- Welders
- Plasma Cutters
- Instrumentation
- Test Equipment
- Enclosures and more

- Customized fan performances at multiple operating points.
- Peak efficiency resulting in lower total ownership costs.
- Cost effective and better reliability.

Life Expectancy L10

60°C 40,000 Hours

Specifications

MODEL	Rated Voltage	Operating Voltage	Current		Input Power		Speed	Max. Air Flow		Max. Static Pressure		Noise	Mass
	(V)	(V)	Avg	Max	Avg	Max		(CFM)	(m³/min)	(inH ₂ O)	(Pa)		
	(V)	(V)	(A) ^{*1}	(A) ^{*1}	(W) ^{*1}	(W) ^{*1}	(min ⁻¹) ^{*1}	(CFM)	(m³/min)	(inH ₂ O)	(Pa)	(dB) ^{*1}	(g)
11925SA-12R-EUD-1	12	7.0~13.2	0.62	0.86	7.44	10.32	3500	128.2	3.63	0.36	89	47.0	165

*1: Values in Free Air

PWM Specifications

● CONNECTION

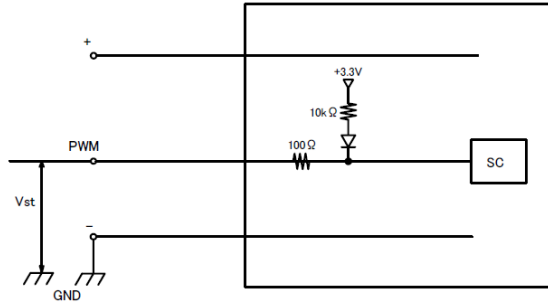

1. PWM Control

- V_{st} = Low Level (0V~0.4V) → Stop (On Duty 0%)
- V_{st} = High Level (4.0V~5.0V) → Full Speed (On Duty 100%)
- V_{st} = Open → Full Speed

2. PWM Duty & PWM Input Pulse

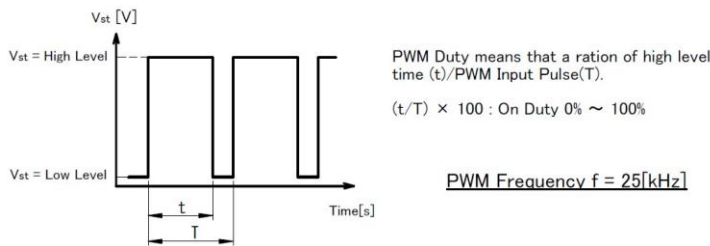

PWM Characteristics Curve

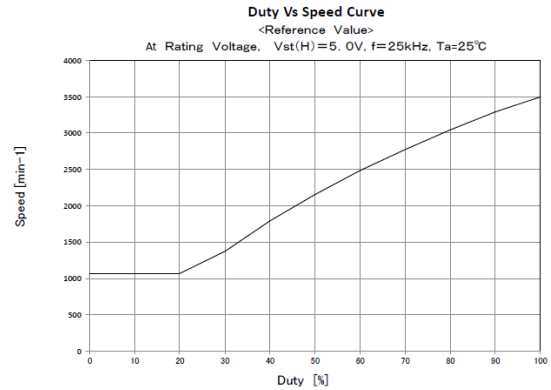

3. The condition for PWM control are as follows.

- When you use this under PWM control, always be sure the motor's operation under practical mounting state. Fan motor may not start up caused by PWM control at very low speed condition.
- To run at Rating Voltage.

TACHO Specifications

TACHOMETER SIGNAL

1. OUTPUT CIRCUIT : OPEN DRAIN
2. SPECIFICATION
 - T_a=25°C
 - Absolute Maximum Ratings at T_a=25°C
 - V_{DS} max : +15V
 - I_D max : 5mA [V_{DS(sat)}max = 1.0V]

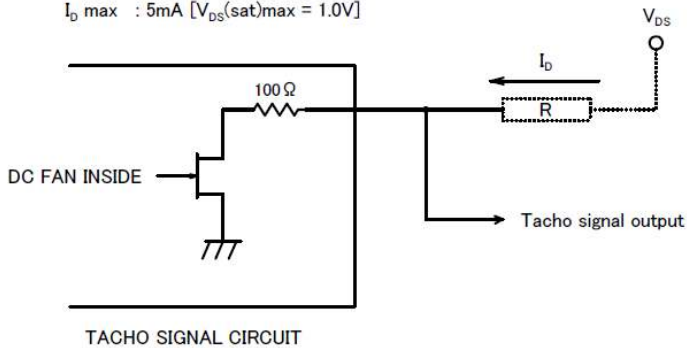

3. OUTPUT WAVEFORM : AT RATED VOLTAGE

4. OUTPUT SIGNAL VOLTAGE

3-1 Case-1

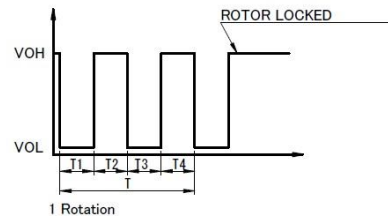

3-2 Case-2

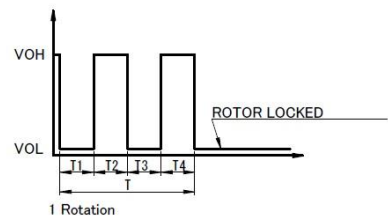

- 1) When the rotor is locked at V_{OH} position of signal, signal keeps V_{OH} position.
- 2) When the rotor is locked at V_L position of signal, signal keeps V_L position.
- 3) T = T₁ + T₂ + T₃ + T₄ = 60° / m = 1 rotation

m : min - 1

Tach Duty Cycle = 50% ± 10%

Panel Cut-Outs

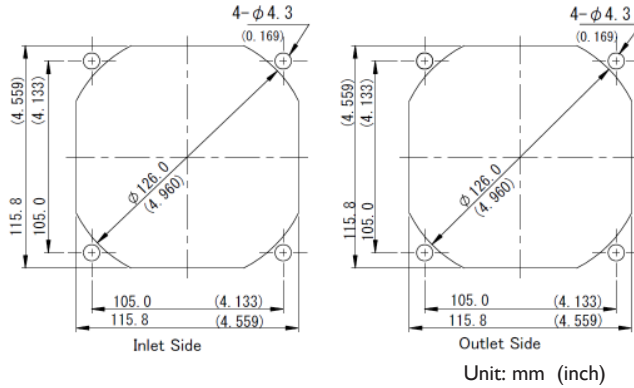

Materials

- Casing : Plastic (Black UL94V-0)
- Impeller : Plastic (Black UL94V-0)
- Bearing : Ball Bearing
- Lead Wire : UL3385 AWG26
- (+) : Red (-) : Black
- PWM : Brown Tach : White

Outline

Name Plate

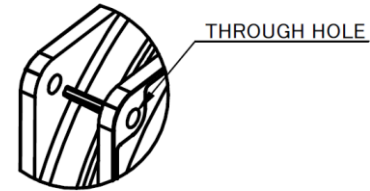
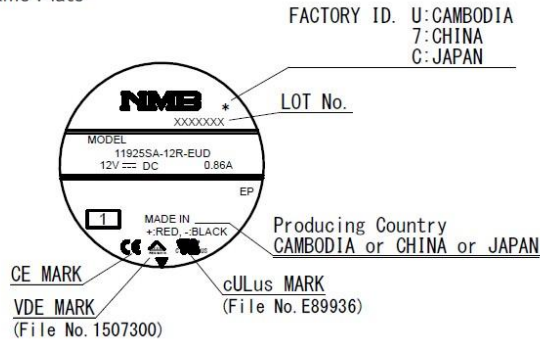

FLANGE TYPE

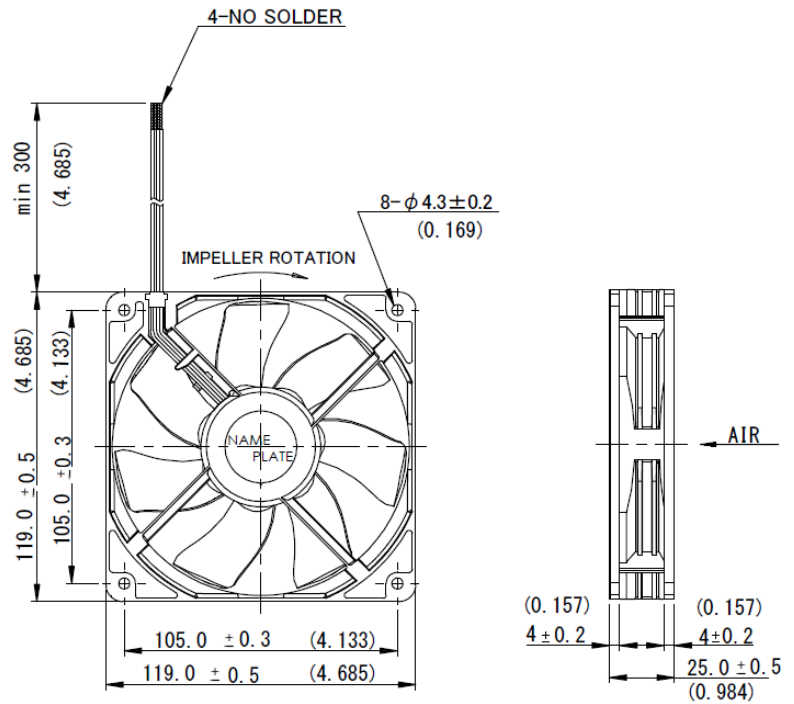

Unit: mm (inch)