

REVISIONS					
P	LTR	DESCRIPTION	DATE	DWN	APVD
	H	See ECO-19-012594	8/12/2019	J.B.	T.L.

Raychem TAK- Sleeve Adhesive-Lined Modified PVDF Tubing

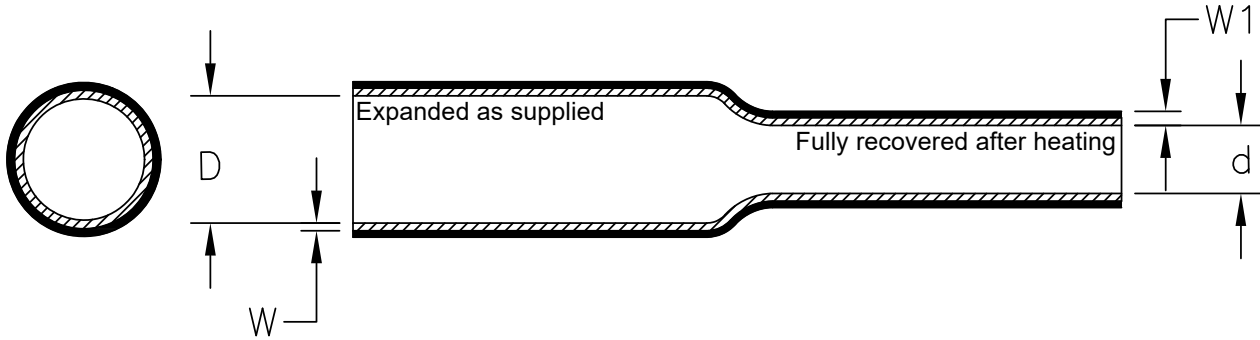

Table 1: Dimensions mm (inches)

Size	As Supplied				As Recovered			
	Expanded Inside Diameter (D)		Adhesive Wall Nominal (W)		Inside Diameter Maximum (d)		Total Wall Minimum (W1)	
	mm.	in.	mm.	in.	mm.	in.	mm.	in.
1/8	3.18 min	0.125 min	0.13	0.005	1.02	0.040	0.483	0.019
3/16	4.75 min	0.187 min	0.13	0.005	1.78	0.070	0.533	0.021
1/4	6.35 min	0.250 min	0.13	0.005	2.67	0.105	0.457	0.018
3/8	9.53 min	0.375 min	0.13	0.005	4.19	0.165	0.483	0.019
1/2	12.70 min	0.500 min	0.13	0.005	6.35	0.250	0.635	0.025
No. 1	12.70 min	0.500 min	0.33	0.013	6.35	0.250	0.635	0.025
No. 2	19.05 min	0.750 min	0.25	0.010	6.35	0.250	0.889	0.035
No. 3	5.21 min	0.205 min	0.13	0.005	1.78	0.070	0.533	0.021
No. 4	5.59 ± 0.25	0.220 ± 0.010	0.25	0.010	2.41	0.095	0.483	0.019

Color: Transparent Jacket, amber adhesive
 Reference Specification 108-120020

THIS DRAWING IS UNPUBLISHED.

ALL RIGHTS RESERVED.

© COPYRIGHT 2019 TE Connectivity

DIMENSIONS: INCHES	DWN J. BITTER	7MAY2019	MATERIAL -	FINISH -
	CHK T. LICKO	-	 TE Connectivity Ltd.	
TOLERANCES UNLESS OTHERWISE SPECIFIED: 0 PLC ± - 1 PLC ± - 2 PLC ± - 3 PLC ± - 4 PLC ± - ANGLES ± -	APVD T. LICKO	-		
	PRODUCT SPEC 108-120020	-	SIZE A4	CAGE CODE 00779
	APPLICATION SPEC -	-	DRAWING NO C-TAK-SLEEVE	RESTRICTED TO -
	WEIGHT 0	CUSTOMER DRAWING		SCALE 1:1 SHEET 1 OF 1 REV H