

FEATURES

- 18-bit resolution with no missing codes**
- Throughput: 250 kSPS**
- INL: ± 0.75 LSB typical, ± 1.5 LSB maximum (± 6 ppm of FSR)**
- Dynamic range: 102 dB typical at 250 kSPS**
- Oversampled dynamic range: 125 dB at 1 kSPS**
- Noise-free code resolution: 20 bits at 1 kSPS**
- Effective resolution: 22.7 bits at 1 kSPS**
- SINAD: 101.5 dB typical at 1 kHz**
- THD: -125 dB typical at 1 kHz**
- True differential analog input range: $\pm V_{REF}$**
- 0 V to V_{REF} with V_{REF} up to VDD on both inputs**
- No pipeline delay**
- Single-supply 2.3 V to 5 V operation with
1.8 V/2.5 V/3 V/5 V logic interface**
- Proprietary serial interface
SPI/QSPI/MICROWIRE™/DSP compatible**
- Ability to daisy-chain multiple ADCs**
- Optional busy indicator feature**
- Power dissipation**
 - 1.35 mW at 2.5 V/100 kSPS, 4 mW at 5 V/100 kSPS
 - 1.4 μ W at 2.5 V/100 SPS
- Standby current: 1 nA**
- 10-lead packages: MSOP (MSOP-8 size) and
3 mm \times 3 mm LFCSP (SOT-23 size)**
- Pin-for-pin compatible with the 18-bit [AD7690](#) and
16-bit [AD7693](#), [AD7688](#), and [AD7687](#)**

APPLICATIONS

- Battery-powered equipment**
- Data acquisitions**
- Seismic data acquisition systems**
- Instrumentation**
- Medical instruments**

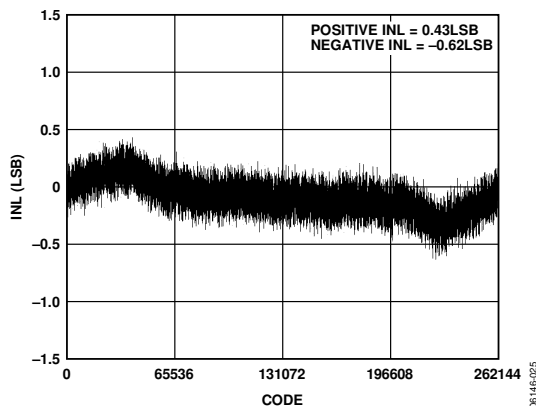

Figure 1. Integral Nonlinearity vs. Code, 5 V

Rev. E

[Document Feedback](#)

Information furnished by Analog Devices is believed to be accurate and reliable. However, no responsibility is assumed by Analog Devices for its use, nor for any infringements of patents or other rights of third parties that may result from its use. Specifications subject to change without notice. No license is granted by implication or otherwise under any patent or patent rights of Analog Devices. Trademarks and registered trademarks are the property of their respective owners.

APPLICATION DIAGRAM

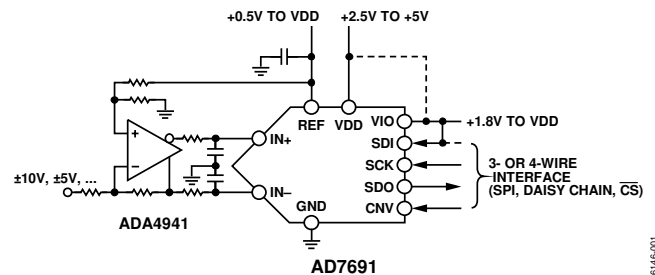

Figure 2.

Table 1. MSOP, LFCSP/SOT-23 14-/16-/18-Bit PuSAR® ADC

Type	100 kSPS	250 kSPS	400 kSPS to 500 kSPS	≥ 1000 kSPS	ADC Driver
18-Bit True Differential		AD7691	AD7690	AD7982 AD7984	ADA4941-1 ADA4841-2
16-Bit True Differential	AD7684	AD7687	AD7688 AD7693		ADA4941-1 ADA4841-2
16-Bit Pseudo Differential	AD7680 AD7683	AD7685 AD7694	AD7686	AD7980	ADA4841-1
14-Bit Pseudo Differential	AD7940	AD7942	AD7946		ADA4841-1

GENERAL DESCRIPTION

The [AD7691](#)¹ is an 18-bit, charge redistribution, successive approximation, analog-to-digital converter (ADC) that operates from a single power supply, VDD, between 2.3 V and 5 V. It contains a low power, high speed, 18-bit sampling ADC with no missing codes, an internal conversion clock, and a versatile serial interface port. On the CNV rising edge, it samples the voltage difference between the IN+ and IN− pins. The voltages on these pins swing in opposite phases between 0 V and REF. The reference voltage, REF, is applied externally and can be set up to the supply voltage.

The part's power scales linearly with throughput.

The SPI-compatible serial interface also features the ability, using the SDI input, to daisy-chain several ADCs on a single 3-wire bus and provides an optional busy indicator. It is compatible with 1.8 V, 2.5 V, 3 V, or 5 V logic, using the separate VIO supply.

The [AD7691](#) is housed in a 10-lead MSOP or a 10-lead LFCSP with operation specified from -40°C to $+85^{\circ}\text{C}$.

¹ Protected by U.S. Patent 6,703,961.

TABLE OF CONTENTS

Features	1	Driver Amplifier Choice	16
Applications.....	1	Single-to-Differential Driver	16
Application Diagram.....	1	Voltage Reference Input	16
General Description.....	1	Power Supply.....	17
Revision History	2	Supplying the ADC from the Reference.....	17
Specifications.....	3	Digital Interface.....	17
Timing Specifications	5	$\overline{\text{CS}}$ Mode, 3-Wire Without Busy Indicator	18
Absolute Maximum Ratings.....	7	$\overline{\text{CS}}$ Mode, 3-Wire with Busy Indicator	19
Thermal Resistance	7	$\overline{\text{CS}}$ Mode, 4-Wire Without Busy Indicator	20
ESD Caution.....	7	$\overline{\text{CS}}$ Mode, 4-Wire with Busy Indicator	21
Pin Configurations and Function Descriptions	8	Chain Mode Without Busy Indicator	22
Typical Performance Characteristics	9	Chain Mode with Busy Indicator	23
Terminology	13	Application Hints	24
Theory of Operation	14	Layout	24
Circuit Information.....	14	Evaluating the AD7691 Performance	24
Converter Operation.....	14	Outline Dimensions.....	25
Typical Connection Diagram	15	Ordering Guide	25
Analog Inputs.....	15		

REVISION HISTORY

6/15—Rev. D to Rev. E

Change to Digital Interface Section	17
Change to $\overline{\text{CS}}$ Mode, 3-Wire with Busy Indicator Section.....	19
Change to $\overline{\text{CS}}$ Mode, 4-Wire with Busy Indicator Section.....	21
Changes to the Ordering Guide.....	25

7/14—Rev. C to Rev. D

Changed QFN (LFCSP) to LFCSP	Throughout
Changes to Features Section.....	1
Added Patent Note, Note 1.....	1
Change to Acquisition Time Parameter, Table 5.....	6
Changes to Evaluating the AD7691 Performance Section.....	24
Updated Outline Dimensions.....	25
Changes to Ordering Guide	25

3/12—Rev. B to Rev. C

Change to Table 9	14
Changes to Ordering Guide	25

7/11—Rev. A to Rev. B

Changes to Common-Mode Input Range Min Parameter	3
Added EPAD Note to Figure 6 and Table 8.....	8
Updated Outline Dimensions	25

11/07—Rev. 0 to Rev. A

Deleted QFN Package in Development References.....	Universal
Changes to Features, Applications, Figure 1 and Figure 2.....	1
Changes to Accuracy, Table 2	3
Changes to Power Dissipation, Table 3.....	4
Added Thermal Resistance Section	7
Changes to Figure 22.....	11
Changes to Format	12
Changes to Terminology Section	13
Changes to Format and Figure 29	15
Inserted Figure 31.....	15
Changes to Format	17
Changes to Figure 44.....	22
Changes to Figure 46.....	23
Updated QFN Outline Dimensions	25
Changes to Ordering Guide	25

7/06—Revision 0: Initial Version

SPECIFICATIONS

VDD = 2.3 V to 5.25 V, VIO = 2.3 V to VDD, VREF = VDD, all specifications T_{MIN} to T_{MAX}, unless otherwise noted.

Table 2.

Parameter	Conditions/Comments	Min	Typ	Max	Unit
RESOLUTION		18			Bits
ANALOG INPUT					
Voltage Range, V _{IN}	IN+ – (IN–)	–V _{REF}		+V _{REF}	V
Absolute Input Voltage	IN+, IN–	–0.1		V _{REF} + 0.1	V
Common-Mode Input Range	IN+, IN–	V _{REF} /2 – 0.1	V _{REF} /2	V _{REF} /2 + 0.1	V
Analog Input CMRR	f _{IN} = 250 kHz		65		dB
Leakage Current at 25°C	Acquisition phase		1		nA
Input Impedance ¹					
THROUGHPUT					
Conversion Rate	VDD = 4.5 V to 5.25 V	0		250	kSPS
	VDD = 2.3 V to 4.5 V	0		180	kSPS
Transient Response	Full-scale step			1.8	μs
ACCURACY					
No Missing Codes		18			Bits
Integral Linearity Error		–1.5	±0.75	+1.5	LSB ²
Differential Linearity Error		–1	±0.5	+1.25	LSB ²
Transition Noise	REF = VDD = 5 V		0.75		LSB ²
Gain Error ³	VDD = 4.5 V to 5.25 V	–40	±2	+40	LSB ²
	VDD = 2.3 V to 4.5 V	–80	±2	+80	LSB ²
Gain Error Temperature Drift			±0.3		ppm/°C
Zero Error ³	VDD = 4.5 V to 5.25 V	–0.8	±0.1	+0.8	mV
	VDD = 2.3 V to 4.5 V	–3.5	±0.7	+3.5	mV
Zero Temperature Drift			±0.3		ppm/°C
Power Supply Sensitivity	VDD = 5 V ± 5%		±0.25		LSB ²
AC ACCURACY ⁴					
Dynamic Range	V _{REF} = 5 V	101	102		dB
Oversampled Dynamic Range ⁵	f _{IN} = 1 kSPS		125		dB
Signal-to-Noise	f _{IN} = 1 kHz, V _{REF} = 5 V	100	101.5		dB
	f _{IN} = 1 kHz, V _{REF} = 2.5 V	95	96.5		dB
Spurious-Free Dynamic Range	f _{IN} = 1 kHz, V _{REF} = 5 V		–125		dB
Total Harmonic Distortion	f _{IN} = 1 kHz, V _{REF} = 5 V		–118		dB
Signal-to-(Noise + Distortion)	f _{IN} = 1 kHz, V _{REF} = 5 V	100	101.5		dB
	f _{IN} = 1 kHz, V _{REF} = 2.5 V	95	96.5		dB
Intermodulation Distortion ⁶			115		dB

¹ See the Analog Inputs section.

² LSB means least significant bit. With the ±5 V input range, one LSB is 38.15 μV.

³ See the Terminology section. These specifications include full temperature range variation but not the error contribution from the external reference.

⁴ All ac accuracy specifications in dB are referred to a full-scale input FSR. Tested with an input signal at 0.5 dB below full scale, unless otherwise specified.

⁵ Dynamic range obtained by oversampling the ADC running at a throughput f_s of 250 kSPS, followed by postdigital filtering with an output word rate f_o.

⁶ f_{IN1} = 21.4 kHz and f_{IN2} = 18.9 kHz, with each tone at –7 dB below full scale.

VDD = 2.3 V to 5.25 V, VIO = 2.3 V to VDD, VREF = VDD, all specifications T_{MIN} to T_{MAX}, unless otherwise noted.

Table 3.

Parameter	Conditions/Comments	Min	Typ	Max	Unit
REFERENCE					
Voltage Range		0.5		VDD + 0.3	V
Load Current	250 kSPS, REF = 5 V		60		μA
SAMPLING DYNAMICS					
–3 dB Input Bandwidth			2		MHz
Aperture Delay	VDD = 5 V		2.5		ns
DIGITAL INPUTS					
Logic Levels					
V _{IL}		–0.3		+0.3 × VIO	V
V _{IH}		0.7 × VIO		VIO + 0.3	V
I _{IL}		–1		+1	μA
I _{IH}		–1		+1	μA
DIGITAL OUTPUTS					
Data Format	Serial 18-bit, twos complement				
Pipeline Delay ¹					
V _{OL}	I _{SINK} = +500 μA			0.4	V
V _{OH}	I _{SOURCE} = –500 μA	VIO – 0.3			V
POWER SUPPLIES					
VDD	Specified performance	2.3		5.25	V
VIO	Specified performance	2.3		VDD + 0.3	V
VIO Range		1.8		VDD + 0.3	V
Standby Current ^{2, 3}	VDD and VIO = 5 V, T _A = 25°C		1	50	nA
Power Dissipation	VDD = 2.5 V, 100 SPS throughput		1.4		μW
	VDD = 2.5 V, 100 kSPS throughput		1.35		mW
	VDD = 2.5 V, 180 kSPS throughput		2.4		mW
	VDD = 5 V, 100 kSPS throughput		4.24	5	mW
	VDD = 5 V, 250 kSPS throughput		10.6	12.5	mW
Energy per Conversion			50		nJ/sample
TEMPERATURE RANGE ⁴					
Specified Performance	T _{MIN} to T _{MAX}	–40		+85	°C

¹ Conversion results are available immediately after completed conversion.

² With all digital inputs forced to VIO or GND as required.

³ During acquisition phase.

⁴ Contact an Analog Devices, Inc., sales representative for the extended temperature range.

TIMING SPECIFICATIONS

VDD = 4.5 V to 5.25 V, VIO = 2.3 V to VDD, VREF = VDD, all specifications T_{MIN} to T_{MAX}, unless otherwise noted.¹

Table 4.

Parameter	Symbol	Min	Typ	Max	Unit
Conversion Time: CNV Rising Edge to Data Available	t _{CONV}	0.5		2.2	μs
Acquisition Time	t _{ACQ}	1.8			μs
Time Between Conversions	t _{CYC}	4			μs
CNV Pulse Width ($\overline{\text{CS}}$ Mode)	t _{CNVH}	10			ns
SCK Period ($\overline{\text{CS}}$ Mode)	t _{SCK}	15			ns
SCK Period (Chain Mode)	t _{SCK}				
VIO Above 4.5 V		17			ns
VIO Above 3 V		18			ns
VIO Above 2.7 V		19			ns
VIO Above 2.3 V		20			ns
SCK Low Time	t _{SCKL}	7			ns
SCK High Time	t _{SCKH}	7			ns
SCK Falling Edge to Data Remains Valid	t _{HSDO}	4			ns
SCK Falling Edge to Data Valid Delay	t _{DSDO}				
VIO Above 4.5 V				14	ns
VIO Above 3 V				15	ns
VIO Above 2.7 V				16	ns
VIO Above 2.3 V				17	ns
CNV or SDI Low to SDO D17 MSB Valid ($\overline{\text{CS}}$ Mode)	t _{EN}				
VIO Above 4.5 V				15	ns
VIO Above 2.7 V				18	ns
VIO Above 2.3 V				22	ns
CNV or SDI High or Last SCK Falling Edge to SDO High Impedance ($\overline{\text{CS}}$ Mode)	t _{DIS}			25	ns
SDI Valid Setup Time from CNV Rising Edge ($\overline{\text{CS}}$ Mode)	t _{SSDICNV}	15			ns
SDI Valid Hold Time from CNV Rising Edge ($\overline{\text{CS}}$ Mode)	t _{HSDICNV}	0			ns
SCK Valid Setup Time from CNV Rising Edge (Chain Mode)	t _{SSCKCNV}	5			ns
SCK Valid Hold Time from CNV Rising Edge (Chain Mode)	t _{HSCKCNV}	10			ns
SDI Valid Setup Time from SCK Falling Edge (Chain Mode)	t _{SSDISCK}	3			ns
SDI Valid Hold Time from SCK Falling Edge (Chain Mode)	t _{HSDISCK}	4			ns
SDI High to SDO High (Chain Mode with Busy Indicator)	t _{DSDOSDI}				
VIO Above 4.5 V				15	ns
VIO Above 2.3 V				26	ns

¹ See Figure 3 and Figure 4 for load conditions.

VDD = 2.3 V to 4.5 V, VIO = 2.3 V to VDD, VREF = VDD, all specifications T_{MIN} to T_{MAX}, unless otherwise noted.¹

Table 5.

Parameter	Symbol	Min	Typ	Max	Unit
Conversion Time: CNV Rising Edge to Data Available	t _{CONV}	0.5		3.7	μs
Acquisition Time	t _{ACQ}	1.8			μs
Time Between Conversions	t _{CYC}	5.5			μs
CNV Pulse Width (CS Mode)	t _{CNVH}	10			ns
SCK Period (CS Mode)	t _{SCK}	25			ns
SCK Period (Chain Mode)	t _{SCK}				
VIO Above 3 V		29			ns
VIO Above 2.7 V		35			ns
VIO Above 2.3 V		40			ns
SCK Low Time	t _{SCKL}	12			ns
SCK High Time	t _{SCKH}	12			ns
SCK Falling Edge to Data Remains Valid	t _{HSDO}	5			ns
SCK Falling Edge to Data Valid Delay	t _{DSDO}				
VIO Above 3 V				24	ns
VIO Above 2.7 V				30	ns
VIO Above 2.3 V				35	ns
CNV or SDI Low to SDO D17 MSB Valid (CS Mode)	t _{EN}				
VIO Above 2.7 V				18	ns
VIO Above 2.3 V				22	ns
CNV or SDI High or Last SCK Falling Edge to SDO High Impedance (CS Mode)	t _{DIS}			25	ns
SDI Valid Setup Time from CNV Rising Edge (CS Mode)	t _{SSDICNV}	30			ns
SDI Valid Hold Time from CNV Rising Edge (CS Mode)	t _{HSDICNV}	0			ns
SCK Valid Setup Time from CNV Rising Edge (Chain Mode)	t _{SSCKCNV}	5			ns
SCK Valid Hold Time from CNV Rising Edge (Chain Mode)	t _{HSCKCNV}	8			ns
SDI Valid Setup Time from SCK Falling Edge (Chain Mode)	t _{SSDISCK}	8			ns
SDI Valid Hold Time from SCK Falling Edge (Chain Mode)	t _{HSDISCK}	10			ns
SDI High to SDO High (Chain Mode with Busy Indicator)	t _{DSDOSDI}			36	

¹ See Figure 3 and Figure 4 for load conditions.

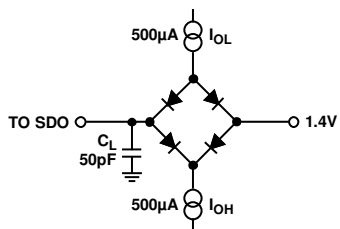

Figure 3. Load Circuit for Digital Interface Timing

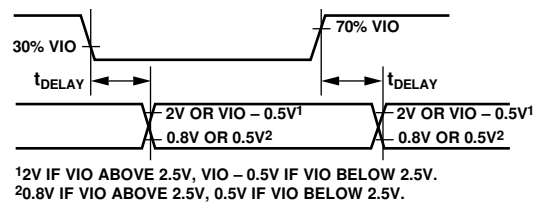

Figure 4. Voltage Levels for Timing

ABSOLUTE MAXIMUM RATINGS

Table 6.

Parameter	Rating
Analog Inputs (IN+, IN–) ¹	GND – 0.3 V to VDD + 0.3 V or ±130 mA
REF	GND – 0.3 V to VDD + 0.3 V
Supply Voltages	
VDD, VIO to GND	–0.3 V to +7 V
VDD to VIO	±7 V
Digital Inputs to GND	–0.3 V to VIO + 0.3 V
Digital Outputs to GND	–0.3 V to VIO + 0.3 V
Storage Temperature Range	–65°C to +150°C
Junction Temperature	150°C
Lead Temperature Range	JEDEC J-STD-20

¹ See the Analog Inputs section.

Stresses at or above those listed under Absolute Maximum Ratings may cause permanent damage to the product. This is a stress rating only; functional operation of the product at these or any other conditions above those indicated in the operational section of this specification is not implied. Operation beyond the maximum operating conditions for extended periods may affect product reliability.

Thermal Resistance

θ_{JA} is specified for the worst-case conditions, that is, a device soldered in a circuit board for surface-mount packages.

Table 7. Thermal Resistance

Package Type	θ_{JA}	θ_{JC}	Unit
10-Lead MSOP	200	44	°C/W
10-Lead LFCSP	43.4	6.5	°C/W

ESD CAUTION



ESD (electrostatic discharge) sensitive device. Charged devices and circuit boards can discharge without detection. Although this product features patented or proprietary protection circuitry, damage may occur on devices subjected to high energy ESD. Therefore, proper ESD precautions should be taken to avoid performance degradation or loss of functionality.

PIN CONFIGURATIONS AND FUNCTION DESCRIPTIONS

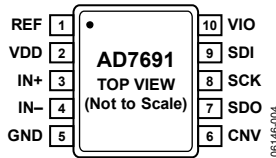
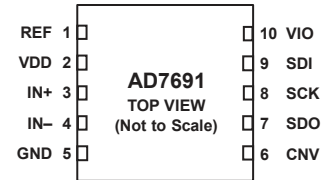

Figure 5. 10-Lead MSOP Pin Configuration



NOTES
 1. THE EXPOSED PAD IS NOT CONNECTED INTERNALLY. FOR INCREASED RELIABILITY OF THE SOLDER JOINTS, IT IS RECOMMENDED THAT THE PAD BE SOLDERED TO THE GROUND PLANE.

Figure 6. 10-Lead LFCSP Pin Configuration

Table 8. Pin Function Descriptions

Pin No.	Mnemonic	Type ¹	Description
1	REF	AI	Reference Input Voltage. The REF range is from 0.5 V to VDD. It is referred to the GND pin. This pin should be decoupled closely to the pin with a 10 μ F capacitor.
2	VDD	P	Power Supply.
3	IN+	AI	Differential Positive Analog Input. Referenced to IN-. The input range for IN+ is between 0 V and V_{REF} , centered about $V_{REF}/2$ and must be driven 180° out of phase with IN-.
4	IN-	AI	Differential Negative Analog Input. Referenced to IN+. The input range for IN- is between 0 V and V_{REF} , centered about $V_{REF}/2$ and must be driven 180° out of phase with IN+.
5	GND	P	Power Supply Ground.
6	CNV	DI	Convert Input. This input has multiple functions. On its leading edge, it initiates the conversions and selects the interface mode of the part, either chain or \overline{CS} mode. In \overline{CS} mode, it enables the SDO pin when low. In chain mode, the data should be read when CNV is high.
7	SDO	DO	Serial Data Output. The conversion result is output on this pin. It is synchronized to SCK.
8	SCK	DI	Serial Data Clock Input. When the part is selected, the conversion result is shifted out by this clock.
9	SDI	DI	Serial Data Input. This input provides multiple features. It selects the interface mode of the ADC as follows: Chain mode is selected if SDI is low during the CNV rising edge. In this mode, SDI is used as a data input to daisy-chain the conversion results of two or more ADCs onto a single SDO line. The digital data level on SDI is output on SDO with a delay of 18 SCK cycles. \overline{CS} mode is selected if SDI is high during the CNV rising edge. In this mode, either SDI or CNV can enable the serial output signals when low, and if SDI or CNV is low when the conversion is complete, the busy indicator feature is enabled.
10	VIO	P	Input/Output Interface Digital Power. Nominally at the same supply as the host interface (1.8 V, 2.5 V, 3 V, or 5 V).
	EPAD		Exposed Pad. The exposed pad is not connected internally. For increased reliability of the solder joints, it is recommended that the pad be soldered to the ground plane.

¹AI = analog input, DI = digital input, DO = digital output, and P = power.

TYPICAL PERFORMANCE CHARACTERISTICS

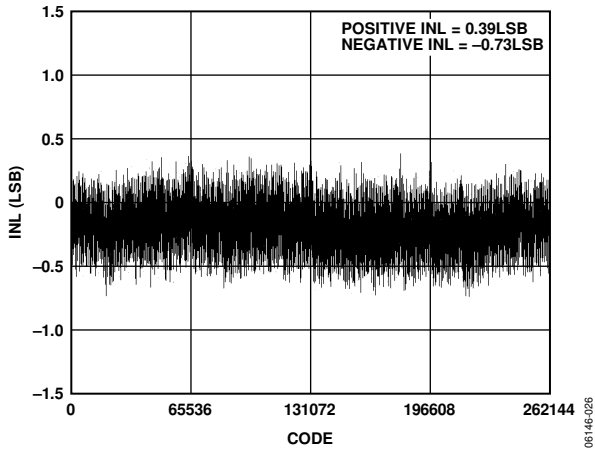

Figure 7. Integral Nonlinearity vs. Code 2.5 V

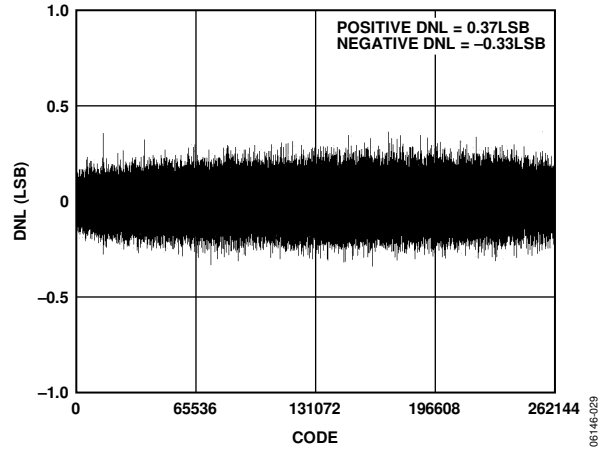

Figure 10. Differential Nonlinearity vs. Code, 5 V

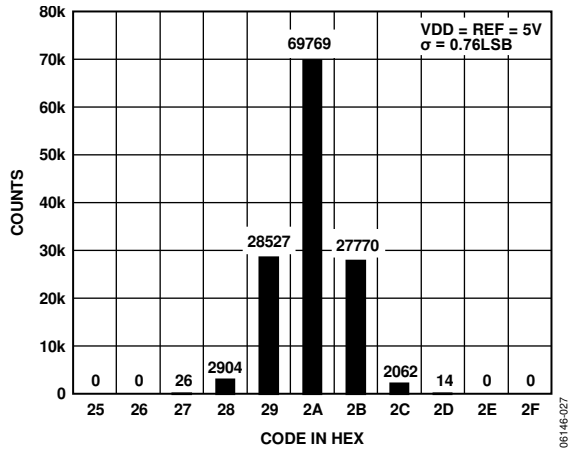

Figure 8. Histogram of a DC Input at the Code Center, 5 V

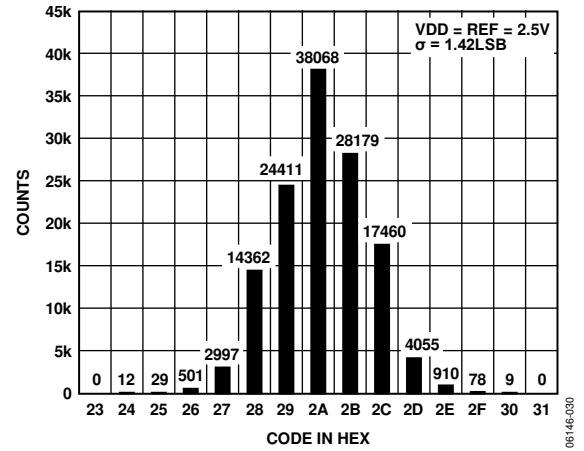

Figure 11. Histogram of a DC Input at the Code Center, 2.5 V

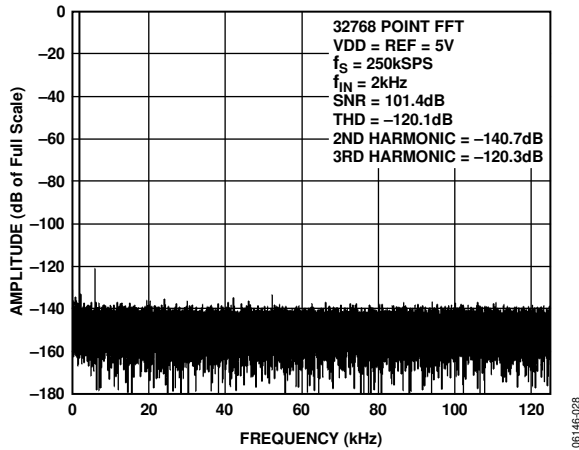

Figure 9. 2 kHz FFT Plot, 5 V

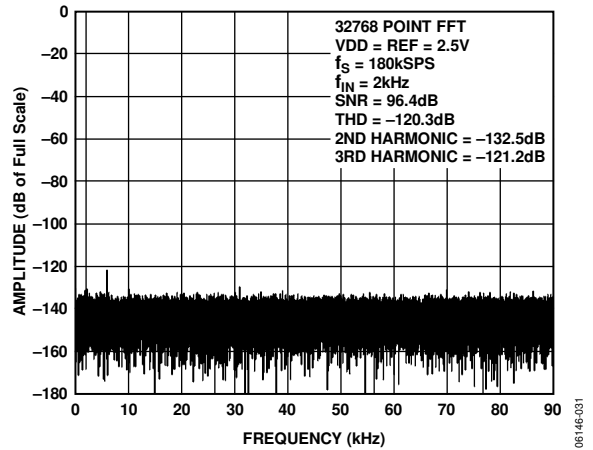

Figure 12. 2 kHz FFT Plot, 2.5 V

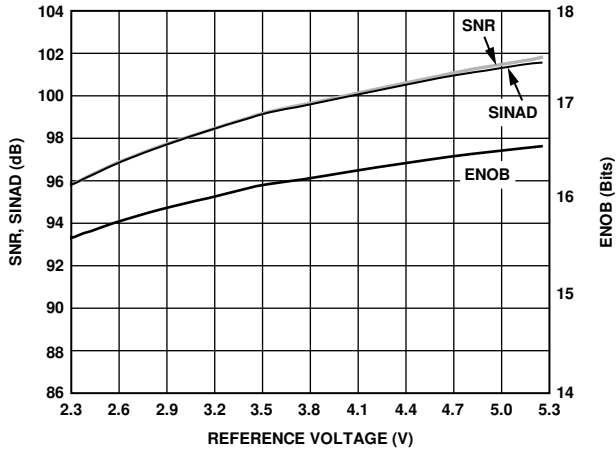

Figure 13. SNR, SINAD, and ENOB vs. Reference Voltage

06146-032

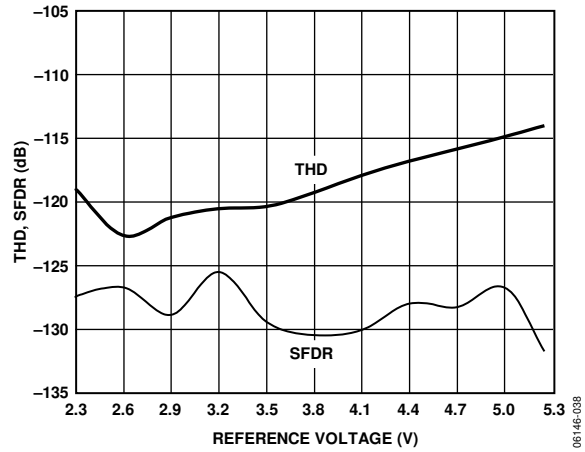

Figure 16. THD, SFDR vs. Reference Voltage

06146-038

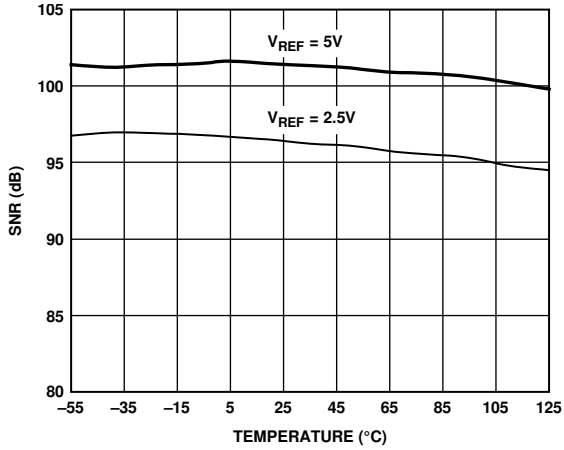

Figure 14. SNR vs. Temperature

06146-033

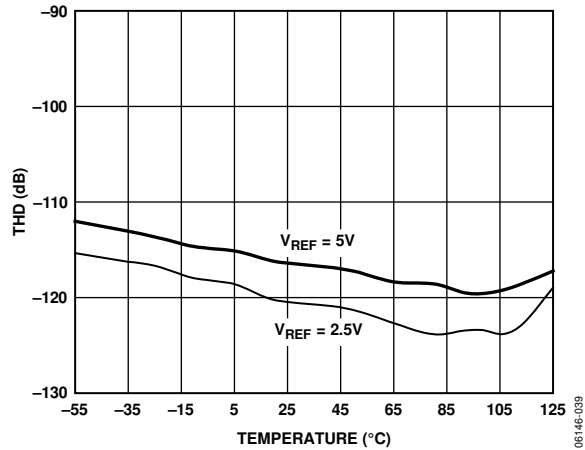

Figure 17. THD vs. Temperature

06146-039

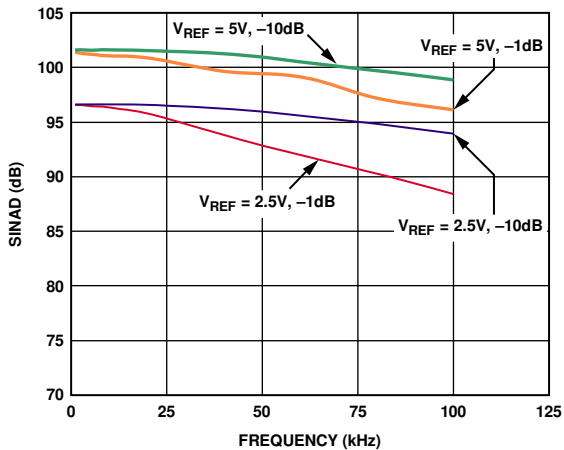

Figure 15. SINAD vs. Frequency

06146-037

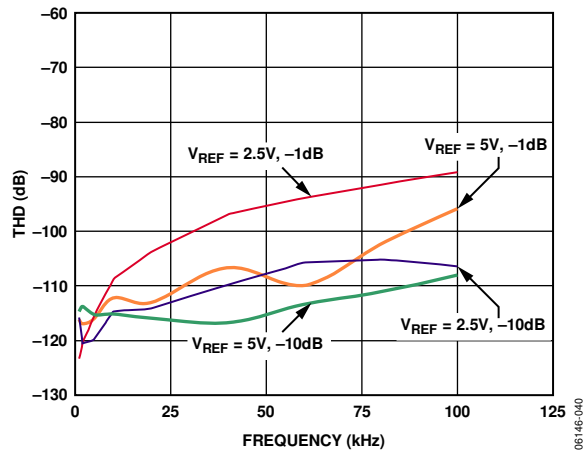

Figure 18. THD vs. Frequency

06146-040

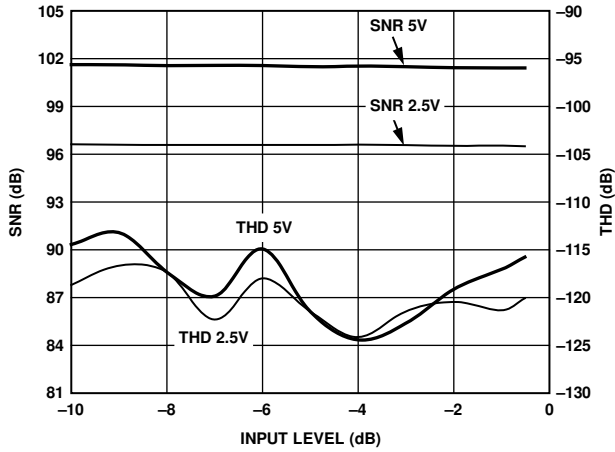

Figure 19. SNR, THD vs. Input Level

06146-041

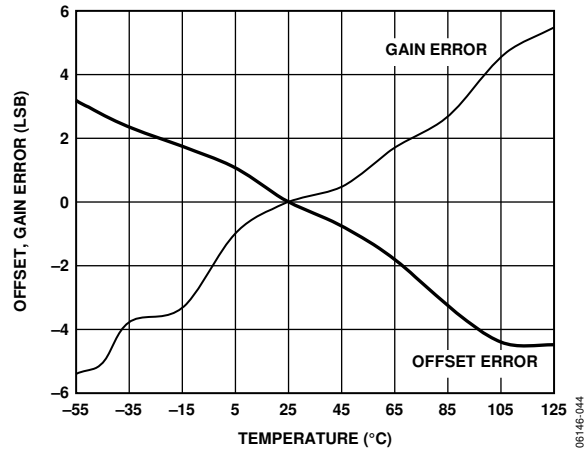

Figure 22. Zero Error, Gain Error vs. Temperature

06146-044

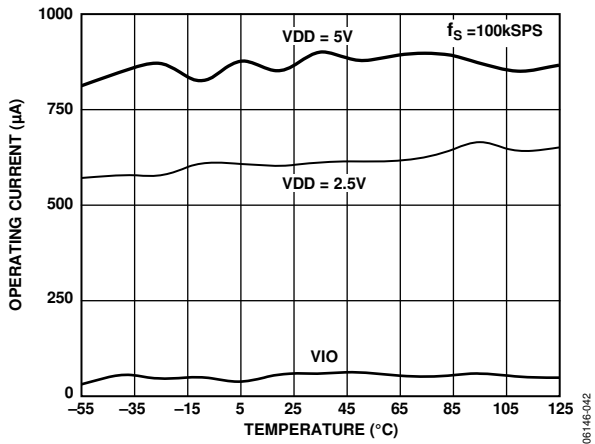

Figure 20. Operating Current vs. Temperature

06146-042

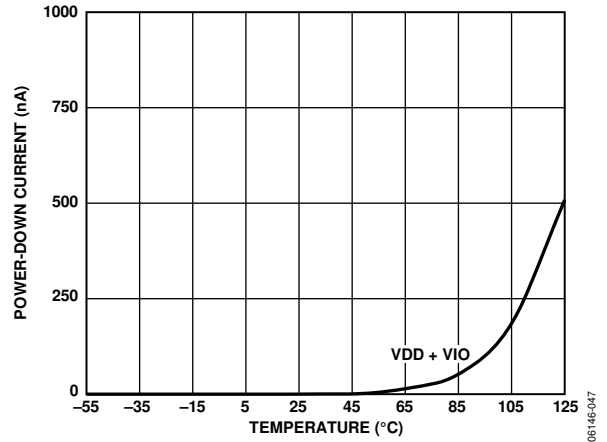

Figure 23. Power-Down Current vs. Temperature

06146-047

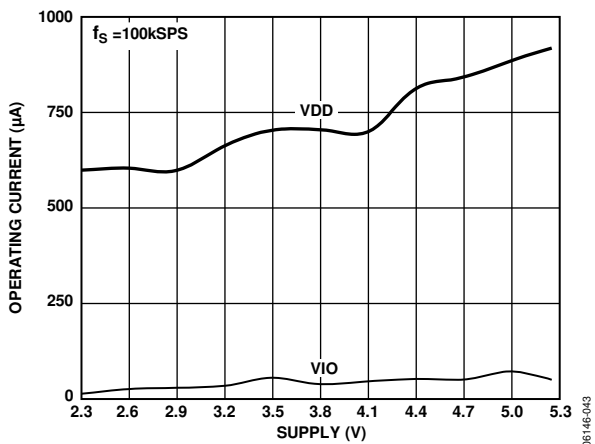

Figure 21. Operating Current vs. Supply

06146-043

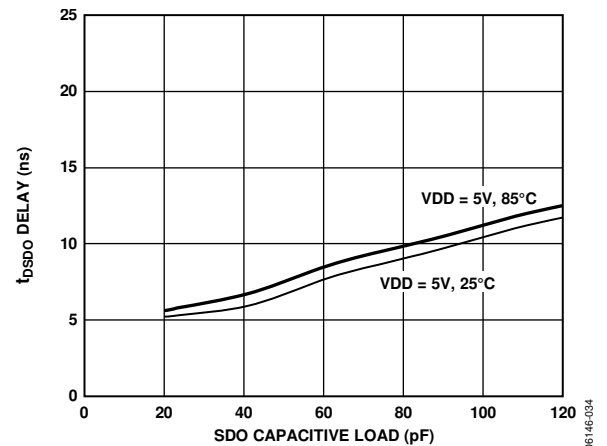

Figure 24. t_{SDO} Delay vs. Capacitance Load and Supply

06146-034

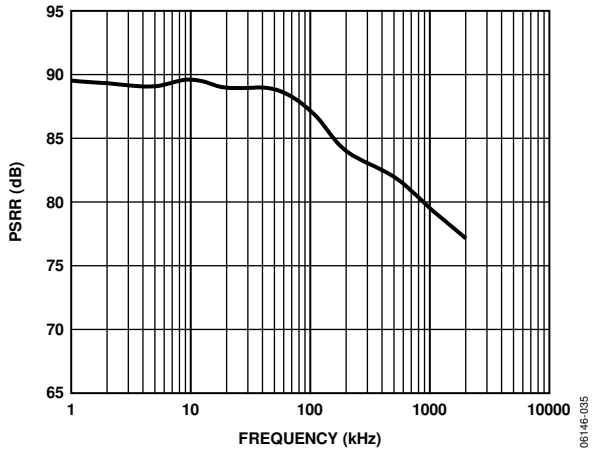

Figure 25. PSRR vs. Frequency

06146-035

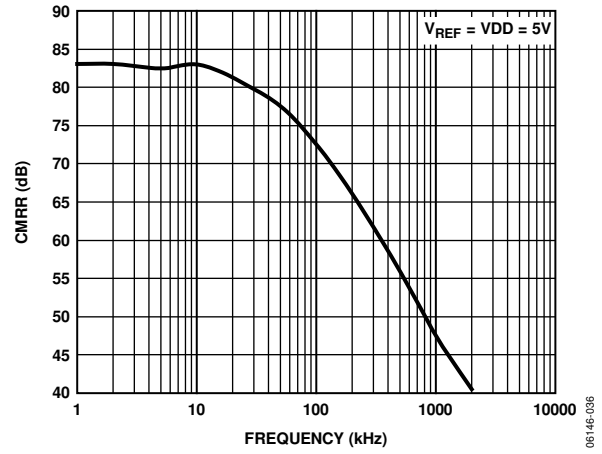

Figure 26. Analog Input CMRR vs. Frequency

06146-038

TERMINOLOGY

Least Significant Bit (LSB)

The least significant bit, or LSB, is the smallest increment that can be represented by a converter. For an analog-to-digital converter with N bits of resolution, the LSB expressed in volts is

$$LSB(V) = \frac{V_{INPP}}{2^N}$$

Integral Nonlinearity Error (INL)

INL refers to the deviation of each individual code from a line drawn from negative full scale through positive full scale. The point used as negative full scale occurs $\frac{1}{2}$ LSB before the first code transition. Positive full scale is defined as a level $1\frac{1}{2}$ LSB beyond the last code transition. The deviation is measured from the middle of each code to the true straight line (see Figure 28).

Differential Nonlinearity Error (DNL)

In an ideal ADC, code transitions are 1 LSB apart. DNL is the maximum deviation from this ideal value. It is often specified in terms of resolution for which no missing codes are guaranteed.

Zero Error

Zero error is the difference between the ideal midscale voltage, that is, 0 V, from the actual voltage producing the midscale output code, that is, 0 LSB.

Gain Error

The first transition (from 100 . . . 00 to 100 . . . 01) should occur at a level $\frac{1}{2}$ LSB above nominal negative full scale (-4.999981 V for the ± 5 V range). The last transition (from 011 . . . 10 to 011 . . . 11) should occur for an analog voltage $1\frac{1}{2}$ LSB below the nominal full scale ($+4.999943$ V for the ± 5 V range). The gain error is the deviation in LSBs (or % of full-scale range) of the difference between the actual level of the last transition and the actual level of the first transition from the difference between the ideal levels. The closely related full-scale error, which is expressed also in LSBs or % of full-scale range, includes the contribution from the zero error.

Spurious-Free Dynamic Range (SFDR)

SFDR is the difference, in decibels, between the rms amplitude of the input signal and the peak spurious signal.

Effective Number of Bits (ENOB)

ENOB is a measurement of the resolution with a sine wave input. It is related to SINAD by the following formula:

$$ENOB = (SINAD_{dB} - 1.76)/6.02$$

and is expressed in bits.

Noise-Free Code Resolution

It is the number of bits beyond which it is impossible to resolve individual codes distinctly. It is calculated as

$$Noise\text{-Free Code Resolution} = \log_2(2^N/Peak\text{-to-Peak Noise})$$

and is expressed in bits.

Effective Resolution

It is calculated as

$$Effective\ Resolution = \log_2(2^N/RMS\ Input\ Noise)$$

and is expressed in bits.

Total Harmonic Distortion (THD)

THD is the ratio of the rms sum of the first five harmonic components to the rms value of a full-scale input signal and is expressed in decibels.

Dynamic Range

Dynamic range is the ratio of the rms value of the full scale to the total rms noise measured with the inputs shorted together. The value for dynamic range is expressed in decibels.

Signal-to-Noise Ratio (SNR)

SNR is the ratio of the rms value of the actual input signal to the rms sum of all other spectral components below the Nyquist frequency, excluding harmonics and dc. The value for SNR is expressed in decibels.

Signal-to-(Noise + Distortion) Ratio (SINAD)

SINAD is the ratio of the rms value of the actual input signal to the rms sum of all other spectral components below the Nyquist frequency, including harmonics but excluding dc. The value for SINAD is expressed in decibels.

Aperture Delay

Aperture delay is the measure of the acquisition performance. It is the time between the rising edge of the CNV input and when the input signal is held for a conversion.

Transient Response

Transient response is the time required for the ADC to acquire its input accurately after a full-scale step function is applied.

THEORY OF OPERATION

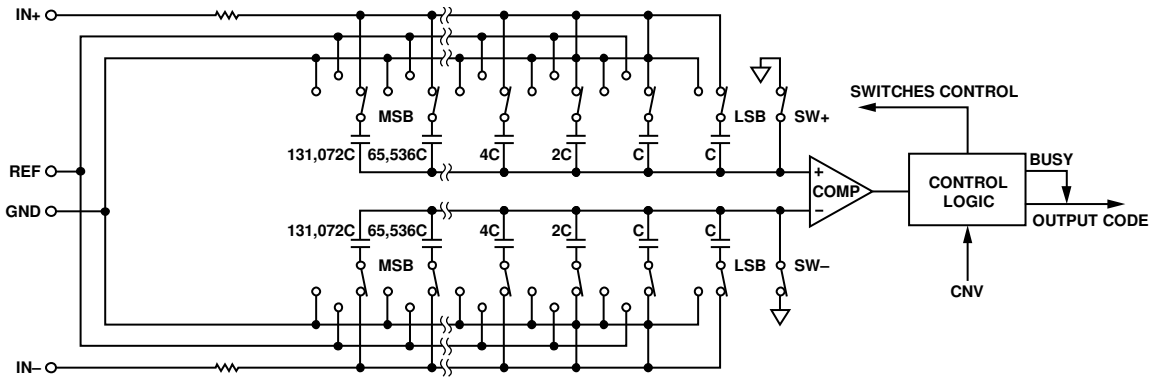

Figure 27. ADC Simplified Schematic

CIRCUIT INFORMATION

The AD7691 is a fast, low power, single-supply, precise, 18-bit ADC using a successive approximation architecture.

The part is capable of converting 250,000 samples per second (250 kSPS) and powers down between conversions. When operating at 1 kSPS, for example, it consumes 50 μ W typically, which is ideal for battery-powered applications.

The AD7691 provides the user with an on-chip track-and-hold and does not exhibit pipeline delay or latency, making it ideal for multiple multiplexed channel applications.

The AD7691 is specified from 2.3 V to 5.25 V and can be interfaced to any 1.8 V to 5 V digital logic family. It is housed in a 10-lead MSOP or a tiny 10-lead LFCSP that combines space savings and allows flexible configurations.

The part is pin-for-pin compatible with the 18-bit AD7690 as well as the 16-bit AD7687 and AD7688.

CONVERTER OPERATION

The AD7691 is a successive approximation ADC based on a charge redistribution DAC. Figure 27 shows the simplified schematic of the ADC. The capacitive DAC consists of two identical arrays of 18 binary-weighted capacitors, which are connected to the two comparator inputs.

During the acquisition phase, terminals of the array tied to the comparator's input are connected to GND via SW+ and SW-. All independent switches are connected to the analog inputs. Thus, the capacitor arrays are used as sampling capacitors and acquire the analog signal on the IN+ and IN- inputs. When the acquisition phase is complete and the CNV input goes high, a conversion phase is initiated. When the conversion phase begins, SW+ and SW- are opened first. The two capacitor arrays are then disconnected from the inputs and connected to the GND input. Therefore, the differential voltage between the inputs IN+ and IN- captured at the end of the acquisition phase is applied to the comparator inputs, causing the comparator to become unbalanced. By switching each element of the capacitor array between GND and REF, the comparator input varies by binary-weighted voltage steps ($V_{REF}/2$, $V_{REF}/4$... $V_{REF}/262,144$).

The control logic toggles these switches, starting with the MSB, to bring the comparator back into a balanced condition. After the completion of this process, the part returns to the acquisition phase, and the control logic generates the ADC output code and a busy signal indicator.

Because the AD7691 has an on-board conversion clock, the serial clock, SCK, is not required for the conversion process.

Transfer Functions

The ideal transfer characteristic for the AD7691 is shown in Figure 28 and Table 9.

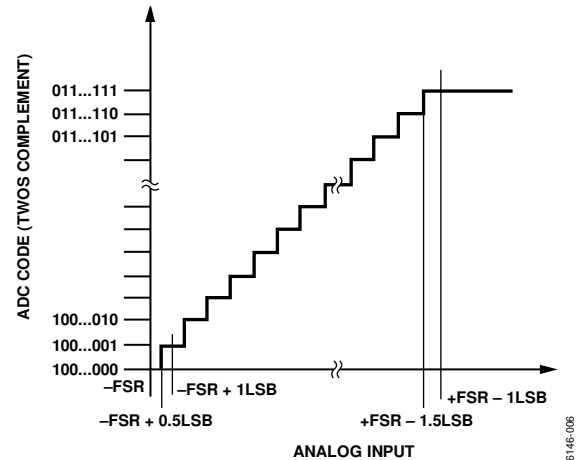

Figure 28. ADC Ideal Transfer Function

Table 9. Output Codes and Ideal Input Voltages

Description	Analog Input $V_{REF} = 5\text{ V}$	Digital Output Code (Hex)
FSR - 1 LSB	+4.999962 V	0x1FFFF ¹
Midscale + 1 LSB	+38.15 μ V	0x00001
Midscale	0 V	0x00000
Midscale - 1 LSB	-38.15 μ V	0x3FFFF
-FSR + 1 LSB	-4.999962 V	0x20001
-FSR	-5 V	0x20000 ²

¹ This is also the code for an overranged analog input ($V_{IN+} - V_{IN-}$ above $V_{REF} - V_{GND}$).

² This is also the code for an underranged analog input ($V_{IN+} - V_{IN-}$ below V_{GND}).

TYPICAL CONNECTION DIAGRAM

Figure 29 shows an example of the recommended connection diagram for the AD7691 when multiple supplies are available.

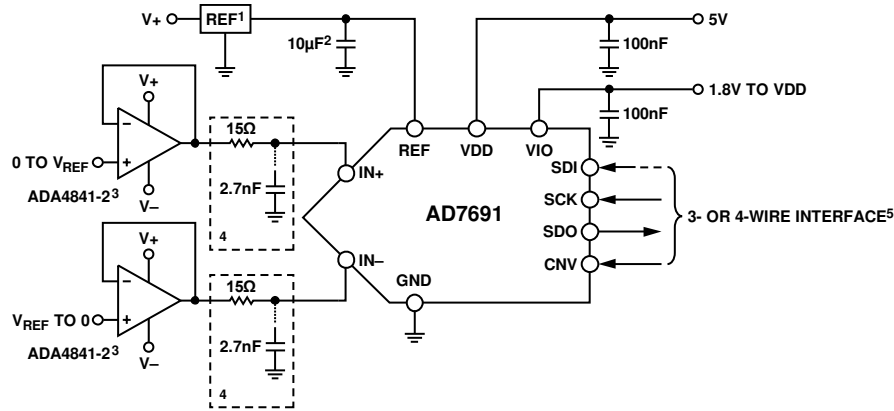

- 1 SEE VOLTAGE REFERENCE INPUT SECTION FOR REFERENCE SELECTION.
- 2 C_{REF} IS USUALLY A 10µF CERAMIC CAPACITOR (X5R).
- 3 SEE TABLE 9 FOR ADDITIONAL RECOMMENDED AMPLIFIERS.
- 4 OPTIONAL FILTER. SEE ANALOG INPUT SECTION.
- 5 SEE THE DIGITAL INTERFACE SECTION FOR MOST CONVENIENT INTERFACE MODE.

06146-008

Figure 29. Typical Application Diagram with Multiple Supplies

ANALOG INPUTS

Figure 30 shows an equivalent circuit of the input structure of the AD7691.

The two diodes, D1 and D2, provide ESD protection for the analog inputs, IN+ and IN-. Care must be taken to ensure that the analog input signal does not exceed the supply rails by more than 0.3 V because this causes the diodes to become forward biased and start conducting current. These diodes can handle a forward-biased current of 130 mA maximum. For instance, these conditions could eventually occur if the input buffer (U1) supplies are different from VDD. In such a case (for example, an input buffer with a short circuit), the current limitation can be used to protect the part.

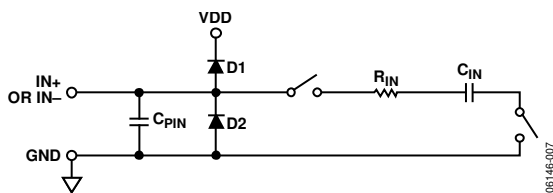

Figure 30. Equivalent Analog Input Circuit

The analog input structure allows the sampling of the true differential signal between IN+ and IN-. By using these differential inputs, signals common to both inputs are rejected.

During the acquisition phase, the impedance of the analog inputs (IN+ and IN-) can be modeled as a parallel combination of the capacitor, C_{PIN}, and the network formed by the series connection of R_{IN} and C_{IN}. C_{PIN} is primarily the pin capacitance. R_{IN} is typically 3 kΩ and is a lumped component composed of serial resistors and the on resistance of the switches. C_{IN} is typically 30 pF and is mainly the ADC sampling capacitor.

During the conversion phase, where the switches are opened, the input impedance is limited to C_{PIN}. R_{IN} and C_{IN} make a 1-pole, low-pass filter that reduces undesirable aliasing effects and limits noise.

When the source impedance of the driving circuit is low, the AD7691 can be driven directly. Large source impedances significantly affect the ac performance, especially total harmonic distortion (THD). The dc performances are less sensitive to the input impedance. The maximum source impedance depends on the amount of THD that can be tolerated.

The THD degrades as a function of the source impedance and the maximum input frequency as shown in Figure 31.

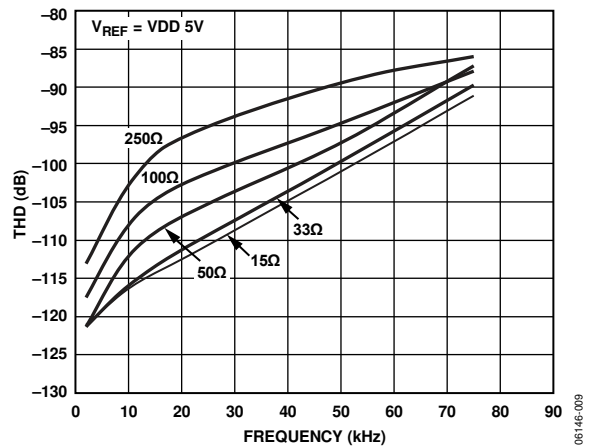

Figure 31. THD vs. Analog Input Frequency and Source Resistance

06146-009

DRIVER AMPLIFIER CHOICE

Although the [AD7691](#) is easy to drive, the driver amplifier must meet the following requirements:

- The noise generated by the driver amplifier needs to be kept as low as possible to preserve the SNR and transition noise performance of the [AD7691](#). The noise coming from the driver is filtered by the [AD7691](#) analog input circuit's 1-pole, low-pass filter made by R_{IN} and C_{IN} or by the external filter, if one is used. The SNR degradation due to the amplifier is as follows:

$$SNR_{LOSS} =$$

$$20 \log \left(\frac{V_{NADC}}{\sqrt{V_{NADC}^2 + \frac{\pi}{2} f_{-3dB} (Ne_{N+})^2 + \frac{\pi}{2} f_{-3dB} (Ne_{N-})^2}} \right)$$

where:

V_{NADC} is the noise of the ADC, in μV , given by the following:

$$V_{NADC} = \frac{\frac{V_{INpp}}{2\sqrt{2}}}{10^{\frac{SNR}{20}}}$$

f_{-3dB} is the input bandwidth, in MHz, of the [AD7691](#) (2 MHz) or the cutoff frequency of the input filter, if one is used.

N is the noise gain of the amplifier (for example, 1 in buffer configuration).

e_{N+} and e_{N-} are the equivalent input noise voltage densities of the op amps connected to $IN+$ and $IN-$, in nV/\sqrt{Hz} .

This approximation can be used when the resistances around the amplifier are small. If larger resistances are used, their noise contributions should also be root-sum-squared.

- For ac applications, the driver should have a THD performance commensurate with the [AD7691](#).
- For multichannel multiplexed applications, the driver amplifier and the [AD7691](#) analog input circuit must settle for a full-scale step onto the capacitor array at an 18-bit level (0.0004%, 4 ppm). In the amplifier's data sheet, settling at 0.1% to 0.01% is more commonly specified. This may differ significantly from the settling time at an 18-bit level and should be verified prior to driver selection.

Table 10. Recommended Driver Amplifiers

Amplifier	Typical Application
ADA4941-1	Very low noise, low power single-ended-to-differential
ADA4841-2	Very low noise, small, and low power
AD8655	5 V single supply, low noise
AD8021	Very low noise and high frequency
AD8022	Low noise and high frequency
OP184	Low power, low noise, and low frequency
AD8605, AD8615	5 V single supply, low power

SINGLE-TO-DIFFERENTIAL DRIVER

For applications using a single-ended analog signal, either bipolar or unipolar, the [ADA4941-1](#) single-ended-to-differential driver allows for a differential input into the part. The schematic is shown in Figure 32.

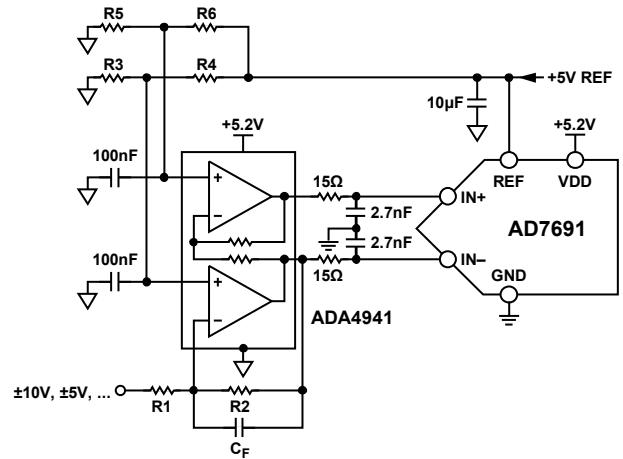

Figure 32. Single-Ended-to-Differential Driver Circuit

$R1$ and $R2$ set the attenuation ratio between the input range and the ADC range (V_{REF}). $R1$, $R2$, and C_F are chosen depending on the desired input resistance, signal bandwidth, antialiasing, and noise contribution. For example, for the $\pm 10 V$ range with a $4 k\Omega$ impedance, $R2 = 1 k\Omega$ and $R1 = 4 k\Omega$.

$R3$ and $R4$ set the common mode on the $IN-$ input, and $R5$ and $R6$ set the common mode on the $IN+$ input of the ADC. The common mode should be set close to $V_{REF}/2$; however, if single supply is desired, it can be set slightly above $V_{REF}/2$ to provide some headroom for the [ADA4941-1](#) output stage. For example, for the $\pm 10 V$ range with a single supply, $R3 = 8.45 k\Omega$, $R4 = 11.8 k\Omega$, $R5 = 10.5 k\Omega$, and $R6 = 9.76 k\Omega$.

VOLTAGE REFERENCE INPUT

The [AD7691](#) voltage reference input, REF, has a dynamic input impedance and should therefore be driven by a low impedance source with efficient decoupling between the REF and GND pins, as explained in the Layout section.

When REF is driven by a very low impedance source, for example, a reference buffer using the [AD8031](#) or the [AD8605](#), a $10 \mu F$ (X5R, 0805 size) ceramic chip capacitor is appropriate for optimum performance.

If an unbuffered reference voltage is used, the decoupling value depends on the reference used. For instance, a $22 \mu F$ (X5R, 1206 size) ceramic chip capacitor is appropriate for optimum performance using a low temperature drift [ADR431](#), [ADR433](#), [ADR434](#), and [ADR435](#) reference.

If desired, smaller reference decoupling capacitor values as low as $2.2 \mu F$ can be used with a minimal impact on performance, especially DNL.

Regardless, there is no need for an additional lower value ceramic decoupling capacitor (for example, 100 nF) between the REF and GND pins.

POWER SUPPLY

The AD7691 uses two power supply pins: a core supply (VDD) and a digital input/output interface supply (VIO). VIO allows direct interface with any logic between 1.8 V and VDD. To reduce the supplies needed, the VIO and VDD pins can be tied together. The AD7691 is independent of power supply sequencing between VIO and VDD. Additionally, it is very insensitive to power supply variations over a wide frequency range, as shown in Figure 25.

The AD7691 powers down automatically at the end of each conversion phase, and therefore, the power scales linearly with the sampling rate. This makes the part ideal for low sampling rate (as low as a few hertz) and low battery-powered applications.

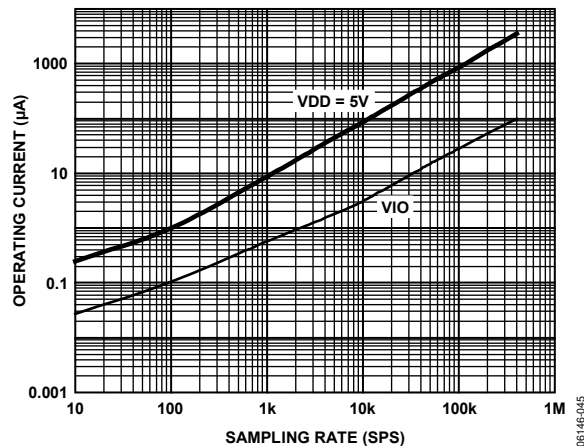
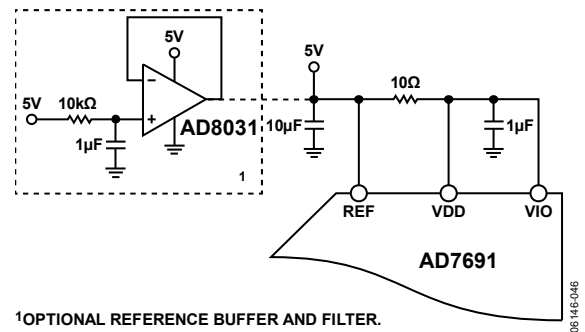

Figure 33. Operating Current vs. Sample Rate

SUPPLYING THE ADC FROM THE REFERENCE

For simplified applications, the AD7691, with its low operating current, can be supplied directly using the reference circuit shown in Figure 34. The reference line can be driven by

- The system power supply directly.
- A reference voltage with enough current output capability, such as the ADR431, ADR433, ADR434, and ADR435.
- A reference buffer, such as the AD8031, which can also filter the system power supply, as shown in Figure 34.



1OPTIONAL REFERENCE BUFFER AND FILTER.

Figure 34. Example of an Application Circuit

DIGITAL INTERFACE

Though the AD7691 has a reduced number of pins, it offers flexibility in its serial interface modes.

When in \overline{CS} mode, the AD7691 is compatible with SPI, QSPI™, digital hosts, and DSPs, for example, the Blackfin® processors or the high performance, mixed-signal DSP family. In this mode, the AD7691 can use either a 3-wire or 4-wire interface. A 3-wire interface using the CNV, SCK, and SDO signals minimizes wiring connections and is useful, for instance, in isolated applications. A 4-wire interface using the SDI, CNV, SCK, and SDO signals allows CNV, which initiates the conversions, to be independent of the readback timing (SDI). This is useful in low jitter sampling or simultaneous sampling applications.

When in chain mode, the AD7691 provides a daisy-chain feature using the SDI input for cascading multiple ADCs on a single data line similar to a shift register.

The mode in which the device operates depends on the SDI level when the CNV rising edge occurs. The \overline{CS} mode is selected if SDI is high, and the chain mode is selected if SDI is low. The SDI hold time is such that when SDI and CNV are connected together, the chain mode is selected.

The initial state of SDO on power up is indeterminate. Therefore, in order to put SDO in a known state, a conversion must be initiated and all data bits clocked out.

In either mode, the AD7691 offers the option of forcing a start bit in front of the data bits. This start bit can be used as a busy signal indicator to interrupt the digital host and trigger the data reading. Otherwise, without a busy indicator, the user must timeout the maximum conversion time prior to readback.

The busy indicator feature is enabled

- In the \overline{CS} mode if CNV or SDI is low when the ADC conversion ends (see Figure 38 and Figure 42).
- In the chain mode if SCK is high during the CNV rising edge (see Figure 46).

$\overline{\text{CS}}$ MODE, 3-WIRE WITHOUT BUSY INDICATOR

This mode is usually used when a single AD7691 is connected to an SPI-compatible digital host. The connection diagram is shown in Figure 35, and the corresponding timing is given in Figure 36.

With SDI tied to VIO, a rising edge on CNV initiates a conversion, selects the $\overline{\text{CS}}$ mode, and forces SDO to high impedance. Once a conversion is initiated, it continues until completion irrespective of the state of CNV. This can be useful, for instance, to bring CNV low to select other SPI devices, such as analog multiplexers, but CNV must be returned high before the minimum conversion time elapses and then held high for the maximum possible conversion time to avoid the generation of the busy signal indicator. When the conversion is complete, the AD7691 enters the acquisition phase and powers down. When CNV goes low, the MSB is output onto SDO. The remaining data bits are clocked by subsequent SCK falling edges.

edges. The data is valid on both SCK edges. Although the rising edge can be used to capture the data, a digital host using the SCK falling edge can allow a faster reading rate, provided it has an acceptable hold time. After the 18th SCK falling edge, or when CNV goes high, whichever occurs first, SDO returns to high impedance.

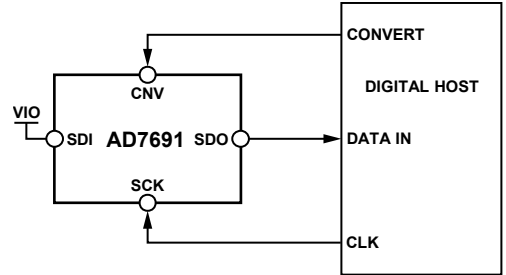

Figure 35. 3-Wire $\overline{\text{CS}}$ Mode Without Busy Indicator Connection Diagram (SDI High)

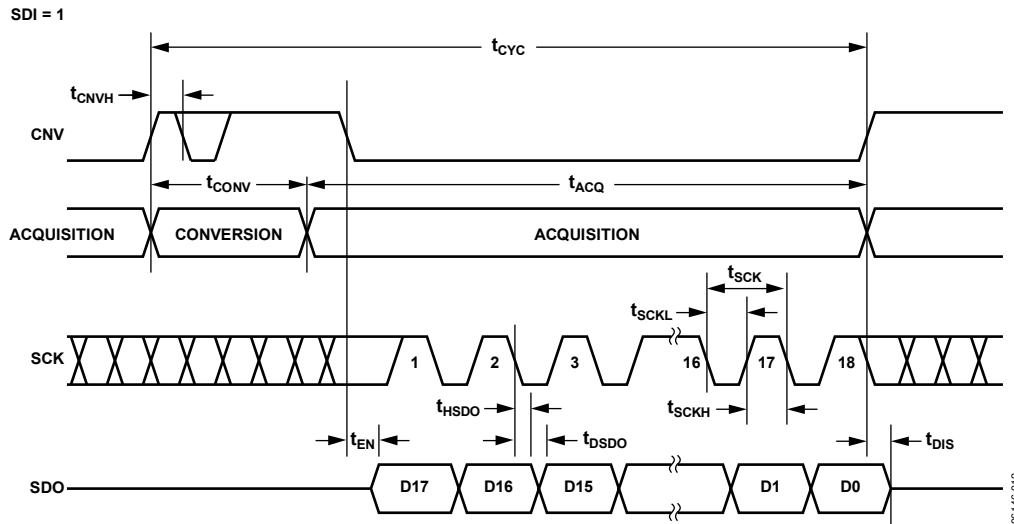

Figure 36. 3-Wire $\overline{\text{CS}}$ Mode Without Busy Indicator Serial Interface Timing (SDI High)

$\overline{\text{CS}}$ MODE, 3-WIRE WITH BUSY INDICATOR

This mode is usually used when a single AD7691 is connected to an SPI-compatible digital host having an interrupt input.

The connection diagram is shown in Figure 37, and the corresponding timing is given in Figure 38.

With SDI tied to VIO, a rising edge on CNV initiates a conversion, selects the $\overline{\text{CS}}$ mode, and forces SDO to high impedance. SDO is maintained in high impedance until the completion of the conversion irrespective of the state of CNV. Prior to the minimum conversion time, CNV can select other SPI devices, such as analog multiplexers, but CNV must be returned low before the minimum conversion time elapses and then held low for the maximum possible conversion time to guarantee the generation of the busy signal indicator. When the conversion is complete, SDO goes from high impedance to low impedance. With a pull-up on the SDO line, this transition is used as an interrupt signal to initiate the data reading controlled by the digital host. When using this option, select the value of the pull-up resistor such that it maintains an appropriate rise time on the SDO line for the application. This is a function of the resistance of the pull-up and the capacitance of the SDO line. The AD7691 then enters the acquisition phase and powers down. The data bits are clocked out, MSB first, by subsequent

SCK falling edges. The data is valid on both SCK edges. Although the rising edge can be used to capture the data, a digital host using the SCK falling edge can allow a faster reading rate, provided it has an acceptable hold time. After the optional 19th SCK falling edge, or when CNV goes high, whichever occurs first, SDO returns to high impedance.

If multiple AD7691 devices are selected at the same time, the SDO output pin handles this contention without damage or induced latch-up. Meanwhile, it is recommended to keep this contention as short as possible to limit extra power dissipation.

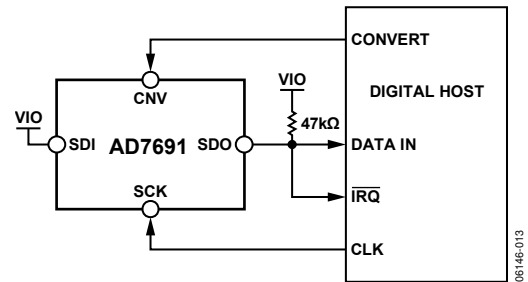

Figure 37. 3-Wire $\overline{\text{CS}}$ Mode with Busy Indicator Connection Diagram (SDI High)

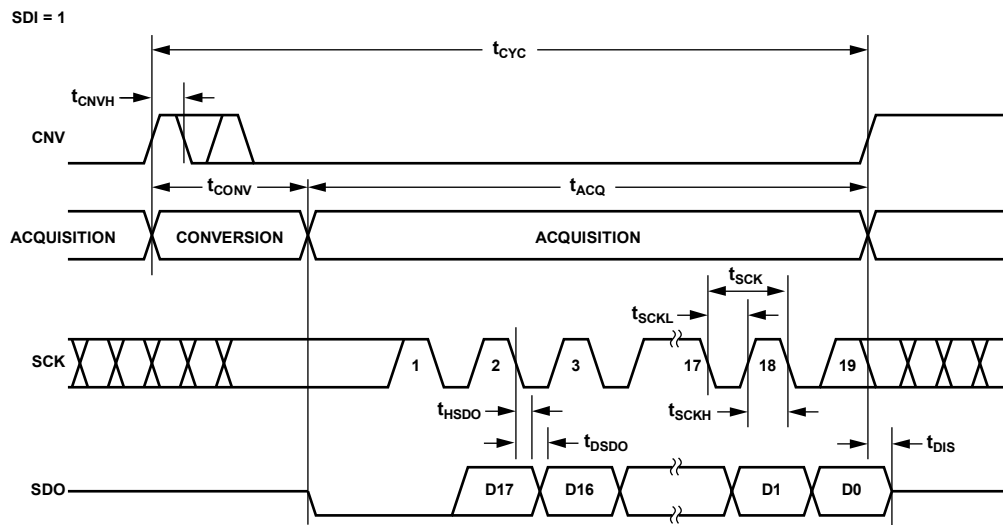

Figure 38. 3-Wire $\overline{\text{CS}}$ Mode with Busy Indicator Serial Interface Timing (SDI High)

$\overline{\text{CS}}$ MODE, 4-WIRE WITHOUT BUSY INDICATOR

This mode is usually used when multiple AD7691 devices are connected to an SPI-compatible digital host.

A connection diagram example using two AD7691 devices is shown in Figure 39, and the corresponding timing is given in Figure 40.

With SDI high, a rising edge on CNV initiates a conversion, selects the $\overline{\text{CS}}$ mode, and forces SDO to high impedance. In this mode, CNV must be held high during the conversion phase and the subsequent data readback. (If SDI and CNV are low, SDO is driven low.) Prior to the minimum conversion time, SDI can be used to select other SPI devices, such as analog multiplexers,

but SDI must be returned high before the minimum conversion time elapses and then held high for the maximum possible conversion time to avoid the generation of the busy signal indicator. When the conversion is complete, the AD7691 enters the acquisition phase and powers down. Each ADC result can be read by bringing its SDI input low, which consequently outputs the MSB onto SDO. The remaining data bits are clocked by subsequent SCK falling edges. The data is valid on both SCK edges. Although the rising edge can be used to capture the data, a digital host using the SCK falling edge allows a faster reading rate, provided it has an acceptable hold time. After the 18th SCK falling edge, or when SDI goes high, whichever occurs first, SDO returns to high impedance and another AD7691 is read.

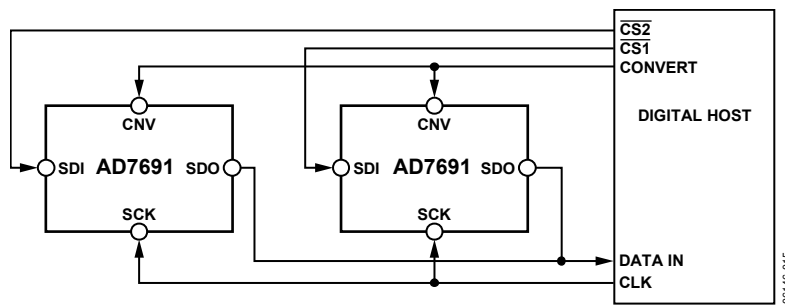

Figure 39. 4-Wire $\overline{\text{CS}}$ Mode Without Busy Indicator Connection Diagram

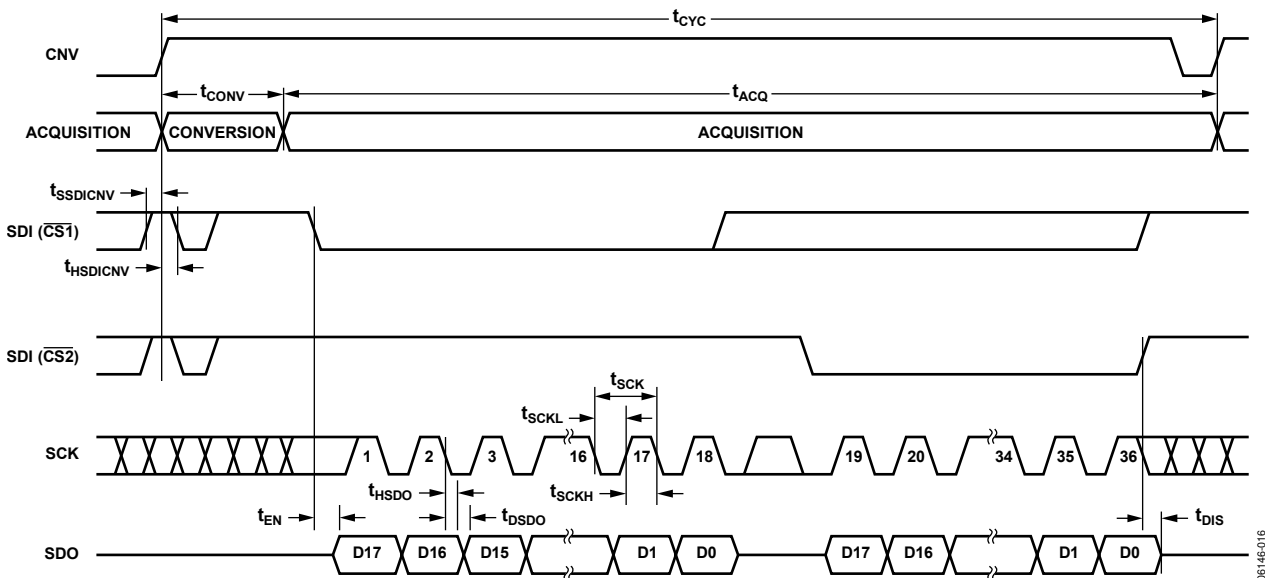

Figure 40. 4-Wire $\overline{\text{CS}}$ Mode Without Busy Indicator Serial Interface Timing

\overline{CS} MODE, 4-WIRE WITH BUSY INDICATOR

This mode is normally used when a single AD7691 is connected to an SPI-compatible digital host with an interrupt input, and it is desired to keep CNV, which is used to sample the analog input, independent of the signal used to select the data reading. This requirement is particularly important in applications where low jitter on CNV is desired.

The connection diagram is shown in Figure 41, and the corresponding timing is given in Figure 42.

With SDI high, a rising edge on CNV initiates a conversion, selects the \overline{CS} mode, and forces SDO to high impedance. In this mode, CNV must be held high during the conversion phase and the subsequent data readback. (If SDI and CNV are low, SDO is driven low.) Prior to the minimum conversion time, SDI can be used to select other SPI devices, such as analog multiplexers, but SDI must be returned low before the minimum conversion time elapses and then held low for the maximum possible conversion time to guarantee the generation of the busy signal indicator. When the conversion is complete, SDO goes from high impedance to low impedance. With a pull-up on the SDO line, this transition is used as an interrupt signal to initiate the data readback controlled by the digital host. When using this option, select the value of the pull-up resistor such that it

maintains an appropriate rise time on the SDO line for the application. This is a function of the resistance of the pull-up and the capacitance of the SDO line. The AD7691 then enters the acquisition phase and powers down. The data bits are clocked out, MSB first, by subsequent SCK falling edges. The data is valid on both SCK edges. Although the rising edge is used to capture the data, a digital host using the SCK falling edge can allow a faster reading rate, provided it has an acceptable hold time. After the optional 19th SCK falling edge, or SDI going high, whichever occurs first, SDO returns to high impedance.

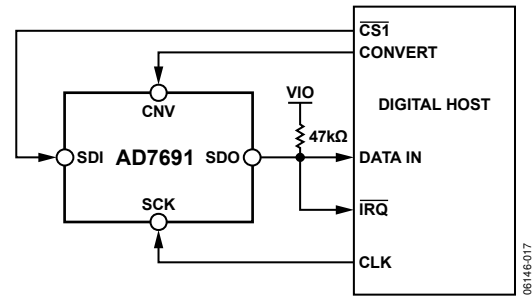

Figure 41. 4-Wire \overline{CS} Mode with Busy Indicator Connection Diagram

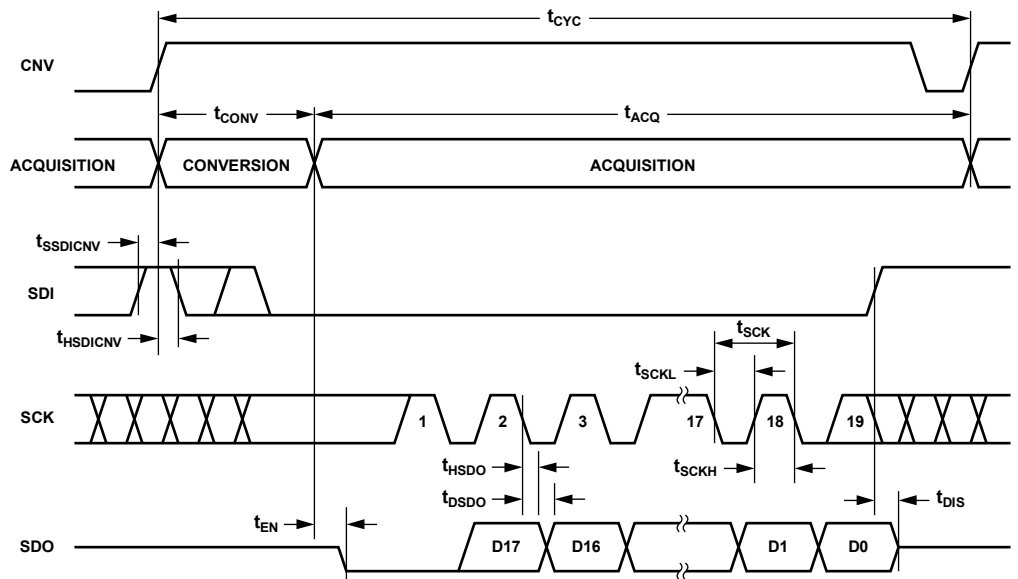

Figure 42. 4-Wire \overline{CS} Mode with Busy Indicator Serial Interface Timing

CHAIN MODE WITHOUT BUSY INDICATOR

This mode can be used to daisy-chain multiple AD7691 devices on a 3-wire serial interface. This feature is useful for reducing component count and wiring connections, for example, in isolated multiconverter applications or for systems with a limited interfacing capacity. Data readback is analogous to clocking a shift register.

A connection diagram example using two AD7691 devices is shown in Figure 43, and the corresponding timing is given in Figure 44.

When SDI and CNV are low, SDO is driven low. With SCK low, a rising edge on CNV initiates a conversion, selects the chain mode, and disables the busy indicator. In this mode, CNV is held high during the conversion phase and the subsequent data

readback. When the conversion is complete, the MSB is output onto SDO and the AD7691 enters the acquisition phase and powers down. The remaining data bits stored in the internal shift register are clocked by subsequent SCK falling edges. For each ADC, SDI feeds the input of the internal shift register and is clocked by the SCK falling edge. Each ADC in the chain outputs its data MSB first, and $18 \times N$ clocks are required to read back the N ADCs. The data is valid on both SCK edges. Although the rising edge can be used to capture the data, a digital host using the SCK falling edge can allow a faster reading rate and, consequently, more AD7691 devices in the chain, provided the digital host has an acceptable hold time. The maximum conversion rate may be reduced due to the total readback time.

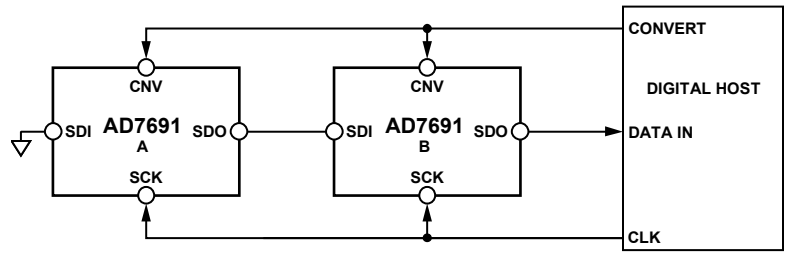

Figure 43. Chain Mode Without Busy Indicator Connection Diagram

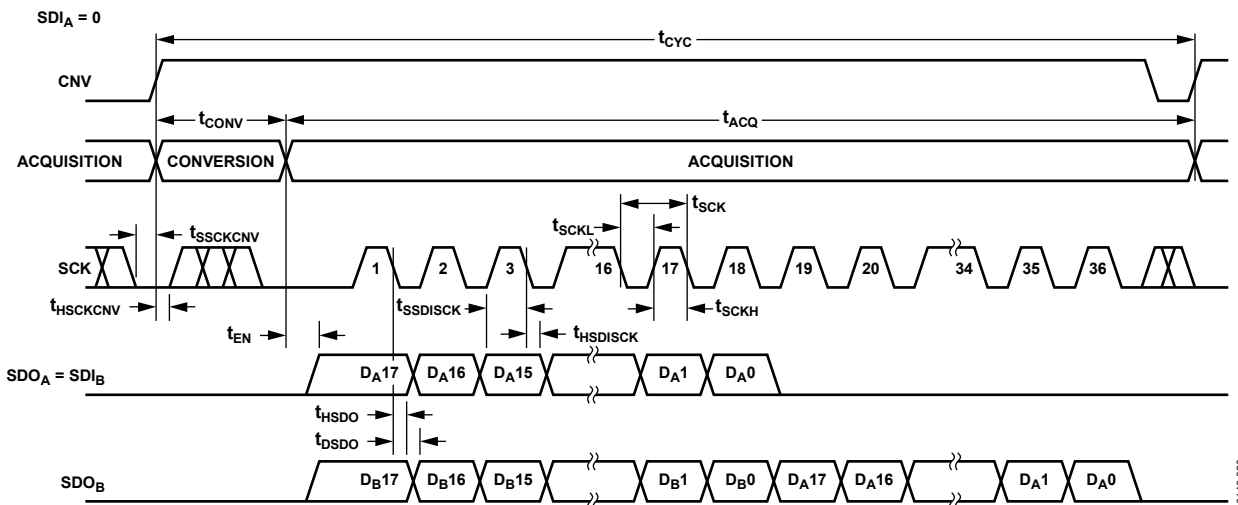

Figure 44. Chain Mode Without Busy Indicator Serial Interface Timing

CHAIN MODE WITH BUSY INDICATOR

This mode can also be used to daisy-chain multiple AD7691 devices on a 3-wire serial interface while providing a busy indicator. This feature is useful for reducing component count and wiring connections, for example, in isolated multiconverter applications or for systems with a limited interfacing capacity. Data readback is analogous to clocking a shift register.

A connection diagram example using three AD7691 devices is shown in Figure 45, and the corresponding timing is given in Figure 46.

When SDI and CNV are low, SDO is driven low. With SCK high, a rising edge on CNV initiates a conversion, selects the chain mode, and enables the busy indicator feature. In this mode, CNV is held high during the conversion phase and the subsequent data readback. When all ADCs in the chain have

completed their conversions, the SDO pin of the ADC closest to the digital host (see the AD7691 ADC labeled C in Figure 45) is driven high. This transition on SDO can be used as a busy indicator to trigger the data readback controlled by the digital host. The AD7691 then enters the acquisition phase and powers down. The data bits stored in the internal shift register are clocked out, MSB first, by subsequent SCK falling edges. For each ADC, SDI feeds the input of the internal shift register and is clocked by the SCK falling edge. Each ADC in the chain outputs its data MSB first, and $18 \times N + 1$ clocks are required to readback the N ADCs. Although the rising edge can be used to capture the data, a digital host using the SCK falling edge allows a faster reading rate and, consequently, more AD7691 devices in the chain, provided the digital host has an acceptable hold time.

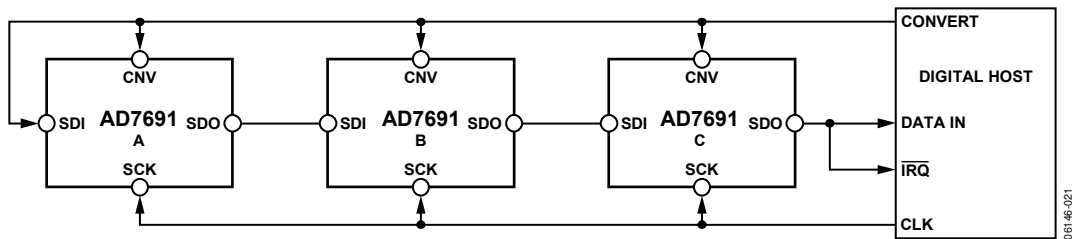

Figure 45. Chain Mode with Busy Indicator Connection Diagram

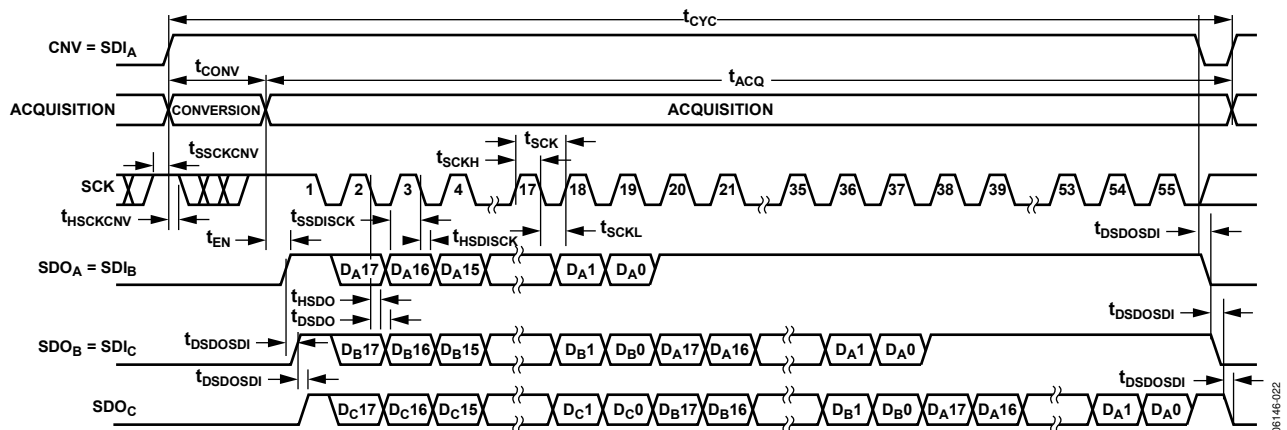

Figure 46. Chain Mode with Busy Indicator Serial Interface Timing

APPLICATION HINTS

LAYOUT

The printed circuit board that houses the [AD7691](#) should be designed so that the analog and digital sections are separated and confined to certain areas of the board. The pin configuration of the [AD7691](#), with its analog signals on the left side and its digital signals on the right side, eases this task.

Avoid running digital lines under the device because this couples noise onto the die unless a ground plane under the [AD7691](#) is used as a shield. Fast switching signals, such as CNV or clocks, should not run near analog signal paths. Crossover of digital and analog signals should be avoided.

At least one ground plane should be used. It can be common or split between the digital and analog sections. In the latter case, the planes should be joined underneath the [AD7691](#).

The [AD7691](#) voltage reference input, REF, has a dynamic input impedance and should be decoupled with minimal parasitic inductances. This is done by placing the reference decoupling ceramic capacitor close to, ideally right up against, the REF and GND pins and connecting them with wide, low impedance traces.

Finally, the power supplies, VDD and VIO, of the [AD7691](#) should be decoupled with ceramic capacitors, typically 100 nF, placed close to the [AD7691](#) and connected using short, wide traces to provide low impedance paths and to reduce the effect of glitches on the power supply lines.

An example layout following these rules is shown in Figure 47 and Figure 48.

EVALUATING THE [AD7691](#) PERFORMANCE

Other recommended layouts for the [AD7691](#) are outlined in the documentation of the evaluation board for the [AD7691](#) ([EVAL-AD7691SDZ](#)). The evaluation board package includes a fully assembled and tested evaluation board, documentation, and software for controlling the board from a PC via the [EVAL-SDP-CB1Z](#).

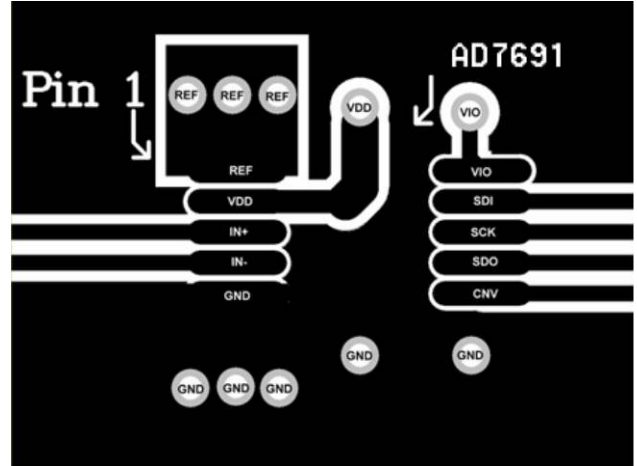

Figure 47. Example Layout of the [AD7691](#) (Top Layer)

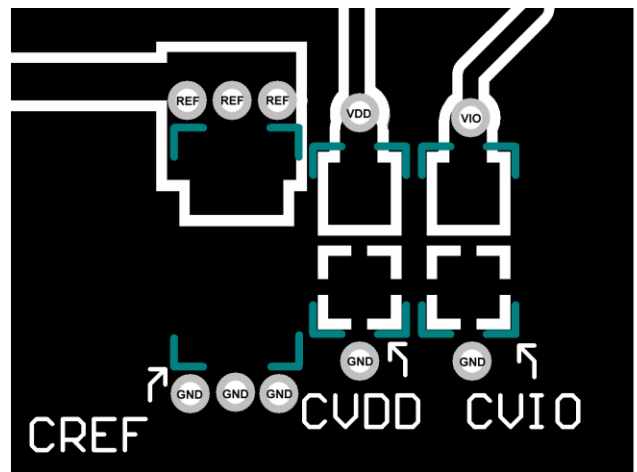
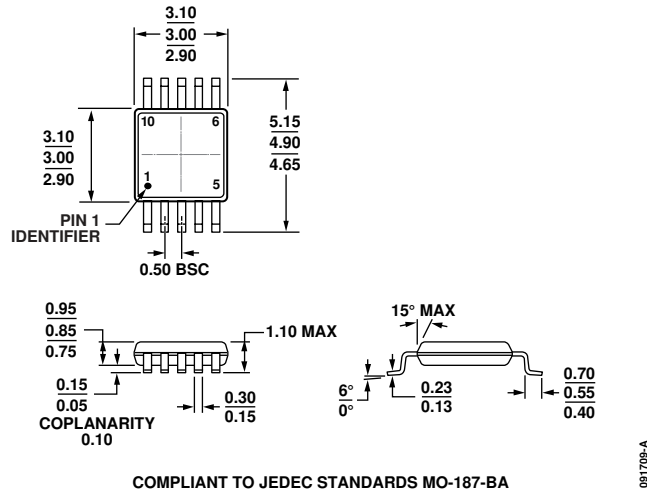

Figure 48. Example Layout of the [AD7691](#) (Bottom Layer)

OUTLINE DIMENSIONS



COMPLIANT TO JEDEC STANDARDS MO-187-BA
 Figure 49. 10-Lead Mini Small Outline Package [MSOP]
 (RM-10)
 Dimensions shown in millimeters

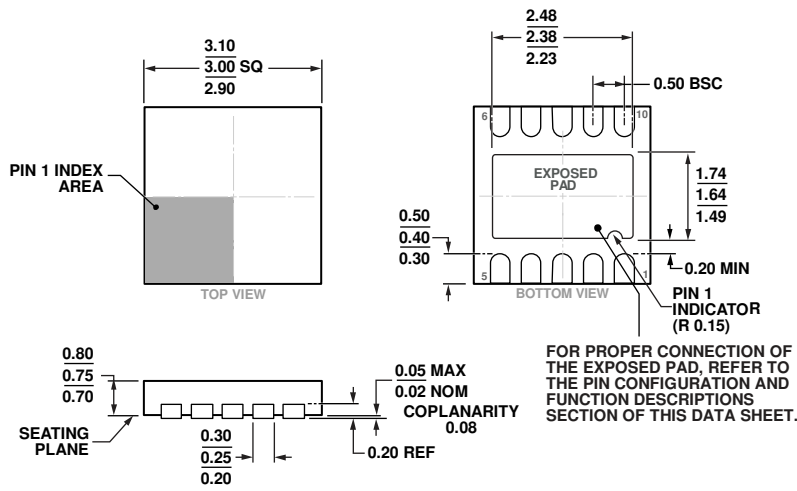

Figure 50. 10-Lead Lead Frame Chip Scale Package [LF CSP_WD]
 3 mm x 3 mm Body, Very Very Thin, Dual Lead
 (CP-10-9)
 Dimensions shown in millimeters

ORDERING GUIDE

Model ^{1, 2, 3}	Temperature Range	Package Description	Package Option	Branding	Ordering Quantity
AD7691BCPZRL	-40°C to +85°C	10-Lead LFCSP_WD	CP-10-9	C4E	Reel, 5,000
AD7691BCPZRL7	-40°C to +85°C	10-Lead LFCSP_WD	CP-10-9	C4E	Reel, 1,500
AD7691BRMZ	-40°C to +85°C	10-Lead MSOP	RM-10	C4E	Tube, 50
AD7691BRMZ-RL7	-40°C to +85°C	10-Lead MSOP	RM-10	C4E	Reel, 1,000
EVAL-AD7691SDZ		Evaluation Board			
EVAL-SDP-CB1Z		Controller Board			

¹ Z = RoHS Compliant Part.

² The EVAL-AD7691SDZ can be used as a standalone evaluation board or in conjunction with the EVAL-SDP-CB1Z for evaluation/demonstration purposes.

³ The EVAL-SDP-CB1Z allows a PC to control and communicate with all Analog Devices evaluation boards ending in the SD designator.

NOTES

NOTES

NOTES