

Materials			
No.	Component name	Base material	Finish
1	Housing	High Temp., UL 94V-0, green	
2	End terminal	silver clad copper alloy	5 microinches min. gold
3	Center terminal	copper alloy	5 microinches min. gold
4	Rocker contact	silver clad copper alloy	5 microinches min. gold
5	Actuator	Phenol resin, UL94 HB, black	
6	Plunger	stainless steel	
7	Spring	music wire	
8	Toggle	brass	chrome or nickel
9	Retainer	Polyamide, UL94 HB, black	
10	Frame	cold rolled steel	zinc or nickel
11	Bushing	brass	100 microinches min. nickel over 10 microinches min. copper
12	Mounting nuts (2)	brass	200 microinches min. bright nickel
13	Locating ring	cold rolled steel	zinc or nickel
14	Internal tooth lockwasher	steel	zinc or nickel
15	Toggle tip	Polyamide, black	

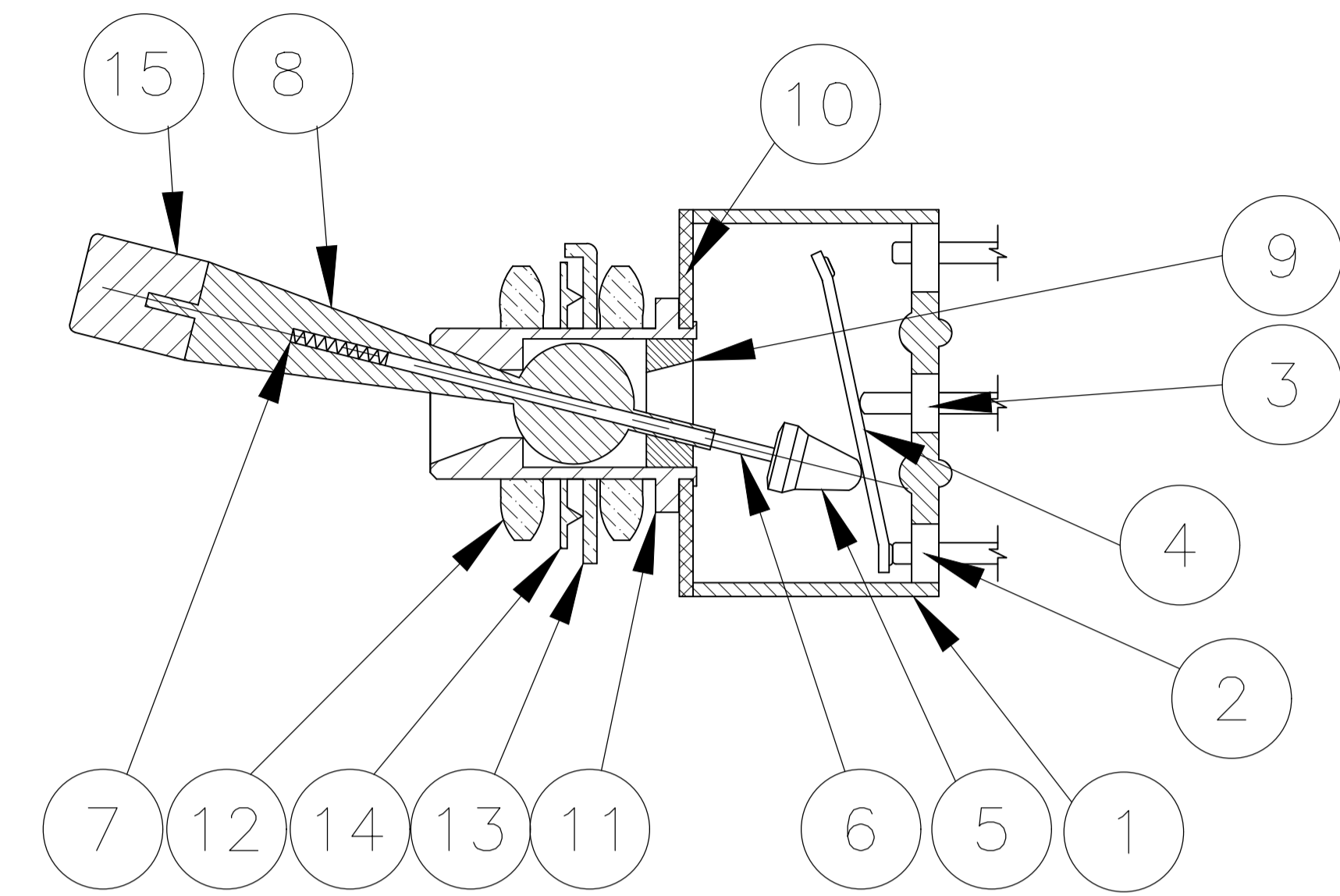

NOT TO SCALE

Specifications-see note 3				
Current rating UL & CSA	6A @ 125 VAC (resistive)			
	3A @ 250 VAC (resistive)			
	4A @ 28 VDC (resistive)			
Termination resistance	20 milliohms max @ 2-4 VDC, 1A			
Insulation resistance	1,000 megohms min.			
Withstanding voltage	1,000 VAC			
Travel	24 +/-6 degrees			
Actuation force	.05 to 1.5 kgf			
Operating temperature	-20C to +85C			
Storage temperature	-40C to +85C			
Contact timing	break before make			
Terminal seal	epoxy or insert molded			
Durability	Parameter	2 Position	3 Position	Momentary
	mechanical (no load)	150,000	100,000	80,000
	250 VAC (3A resistive)	80,000	60,000	60,000
	125 VAC (6A resistive)	80,000	60,000	60,000
	28 VDC (4A resistive)	60,000	50,000	40,000

RECOMMENDED HOLE LAYOUT

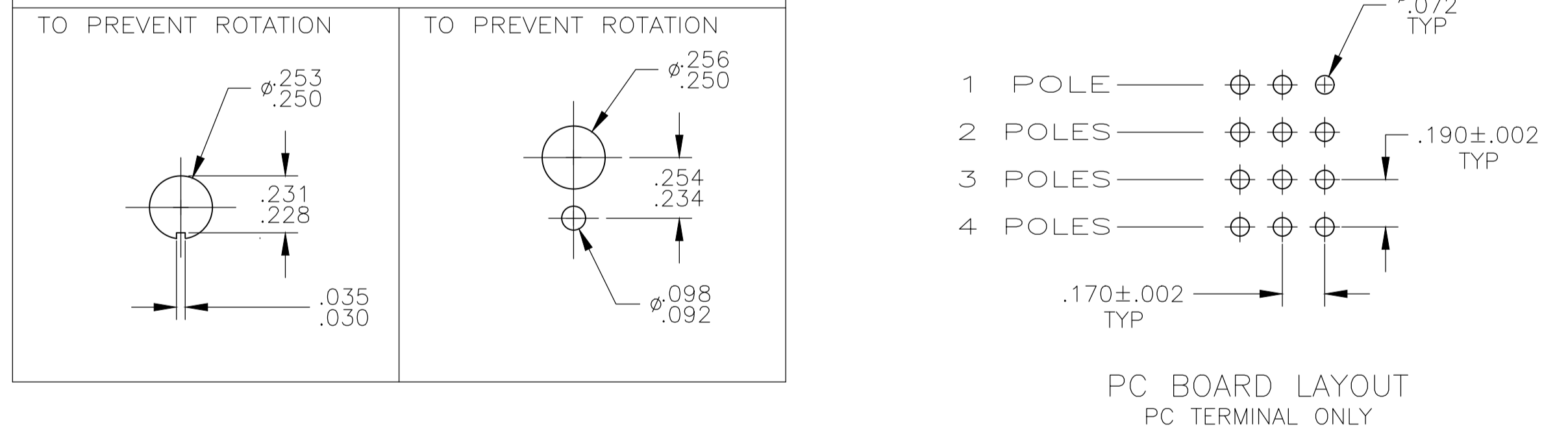

- NOTES:
- TERMINAL NUMBERS ARE FOR REFERENCE ONLY AND DO NOT APPEAR ON THE SWITCHES.
 - EACH SWITCH SUPPLIED WITH THE FOLLOWING MOUNTING HARDWARE:
 - (2) 1/4-40 UNS-2B HEX NUTS
 - (1) INTERNAL TOOTH LOCKWASHER
 - (1) LOCATING RING

- WIRE LUG CONTACTS WILL ACCEPT 2 #20 AWG SOLID OR STRANDED WIRES.
- LASER MARKING USED FOR PARTS.
- OBSOLETE

Part Number	Alco Model	Poles	Throws	Function	Terminal	Terminal Diagrams	Comments
6-1437558-7	MTB406N	4	2	ON ON	Wire lug	<p>3 2 1 6 5 4 9 8 7 12 11 10</p>	2-1, 5-4, 8-7, 11-10
6-1437558-6	MTB306D	3	2	ON ON	Wire lug	<p>3 2 1 6 5 4 9 8 7 12 11 10</p>	2-1, 5-4, 8-7
6-1437558-5	MTB206P	2	2	ON OFF ON	Wire lug	<p>3 2 1 6 5 4 9 8 7 12 11 10</p>	2-1, 5-4
6-1437558-4	MTB206N	2	2	ON ON	Wire lug	<p>3 2 1 6 5 4 9 8 7 12 11 10</p>	2-1, 5-4
6-1437558-3	MTB106E	1	2	ON OFF ON	Wire lug	<p>3 2 1 6 5 4 9 8 7 12 11 10</p>	2-1
6-1437558-2	MTB106D	1	2	ON ON	Wire lug	<p>3 2 1 6 5 4 9 8 7 12 11 10</p>	2-1

THIS DRAWING IS A CONTROLLED DOCUMENT.

DIMENSIONS: INCHES	TOLERANCES UNLESS OTHERWISE SPECIFIED:	DIN M. BINNER 07APR04	TE Connectivity Ltd.
0. PLC ± .005	1. PLC ± .005	CHK M. ZITTO 07APR04	NAME TOGGLE SWITCH, MTB SERIES VERTICAL MOUNT
2. PLC ± .005	3. PLC ± .005	APP'D M. ZITTO 07APR04	PRODUCT SPEC
4. PLC ± .005	ANGLES ± .005	APPLICATION SPEC	SIZE A1
MATERIAL	FINISH	WEIGHT	CAGE CODE 00779
			DRAWING NO. 6-1437558-2
			RESTRICTED TO
			CUSTOMER DRAWING
			SCALE 2:1 SHEET 1 OF 3 REV C4

REVISIONS				
#	DATE	DESCRIPTION	OWN	APP'D
-	-	SEE SHEET 1	-	-

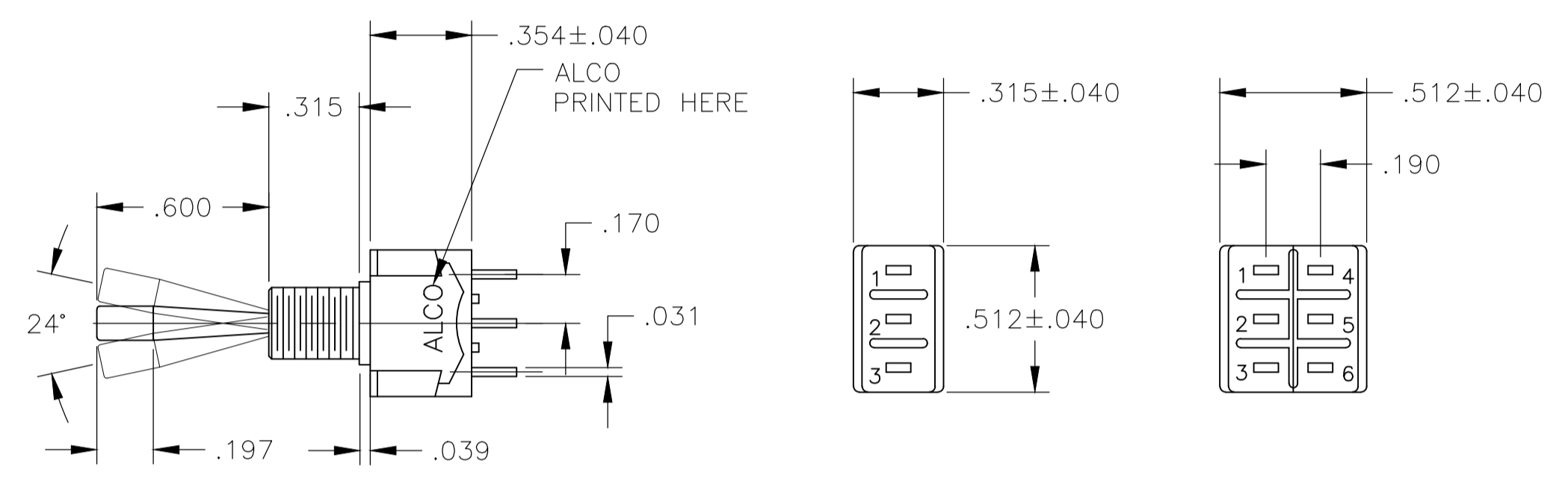

MTB-106 MTB-206

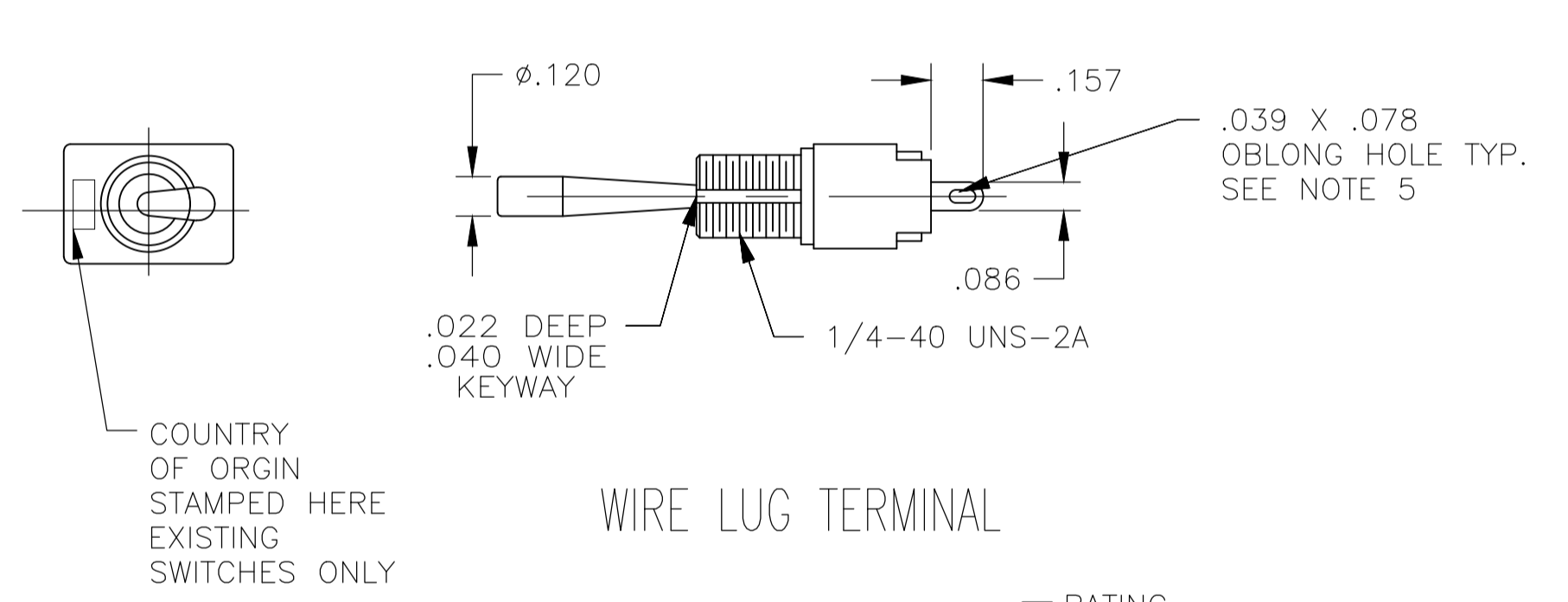

WIRE LUG TERMINAL

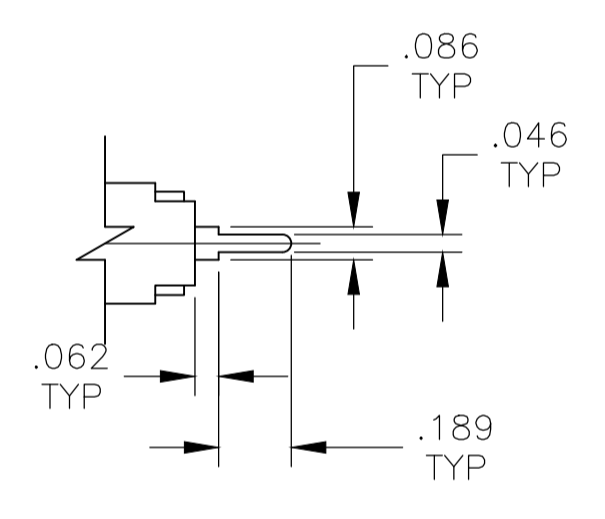

PC TERMINAL

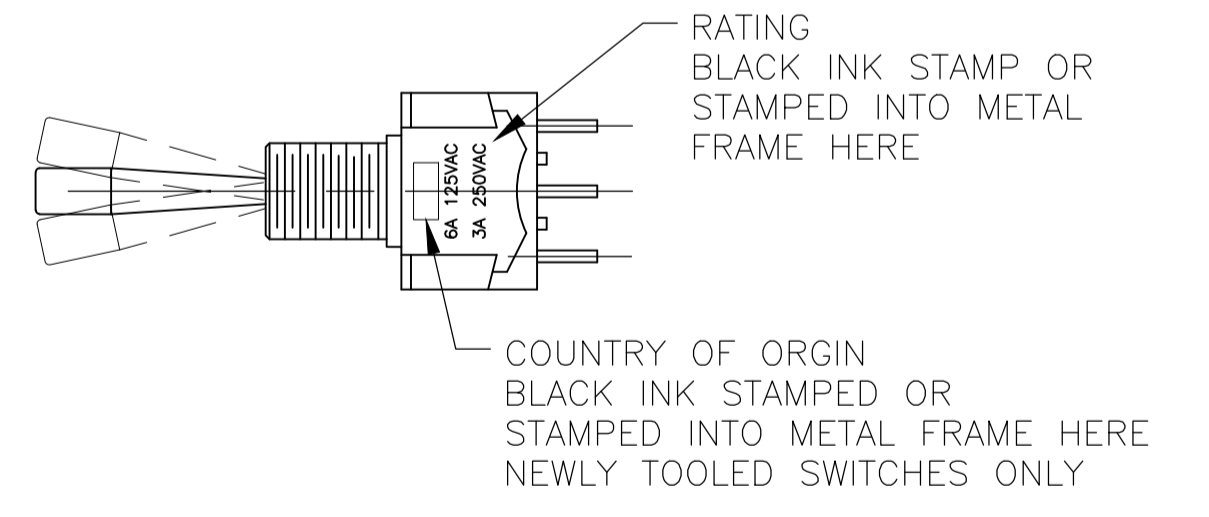

THIS DRAWING IS A CONTROLLED DOCUMENT.		DWN M. BINNER 07APR04	TE Connectivity Ltd.																			
DIMENSIONS: INCHES		CHK M. ZITTO 07APR04	NAME TOGGLE SWITCH, MTB SERIES VERTICAL MOUNT																			
TOLERANCES UNLESS OTHERWISE SPECIFIED:		APP'D M. ZITTO 07APR04	PRODUCT SPEC APPLICATION SPEC																			
<table border="1"> <tr><td>0 PLC</td><td>±</td><td>-</td></tr> <tr><td>1 PLC</td><td>±</td><td>-</td></tr> <tr><td>2 PLC</td><td>±</td><td>-</td></tr> <tr><td>3 PLC</td><td>±</td><td>.005</td></tr> <tr><td>4 PLC</td><td>±</td><td>-</td></tr> <tr><td>ANGLES</td><td>±</td><td>-</td></tr> </table>		0 PLC	±	-	1 PLC	±	-	2 PLC	±	-	3 PLC	±	.005	4 PLC	±	-	ANGLES	±	-	SIZE A1 00779		
0 PLC	±	-																				
1 PLC	±	-																				
2 PLC	±	-																				
3 PLC	±	.005																				
4 PLC	±	-																				
ANGLES	±	-																				
MATERIAL		WEIGHT		RESTRICTED TO																		
FINISH		SCALE 1:1		SHEET 2 OF 3																		
CUSTOMER DRAWING		DRAWING NO. 6-1437558-2		REV C4																		

REVISIONS				
#	LR	DESCRIPTION	DATE	OWN APVD
-	-	SEE SHEET 1	-	-

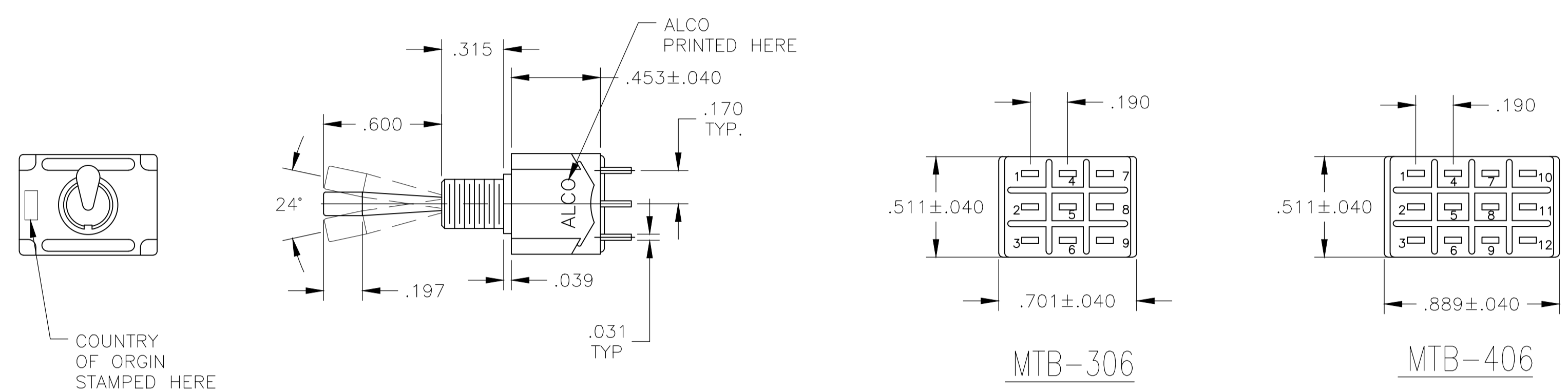

COUNTRY OF ORGIN STAMPED HERE EXISTING SWITCHES ONLY

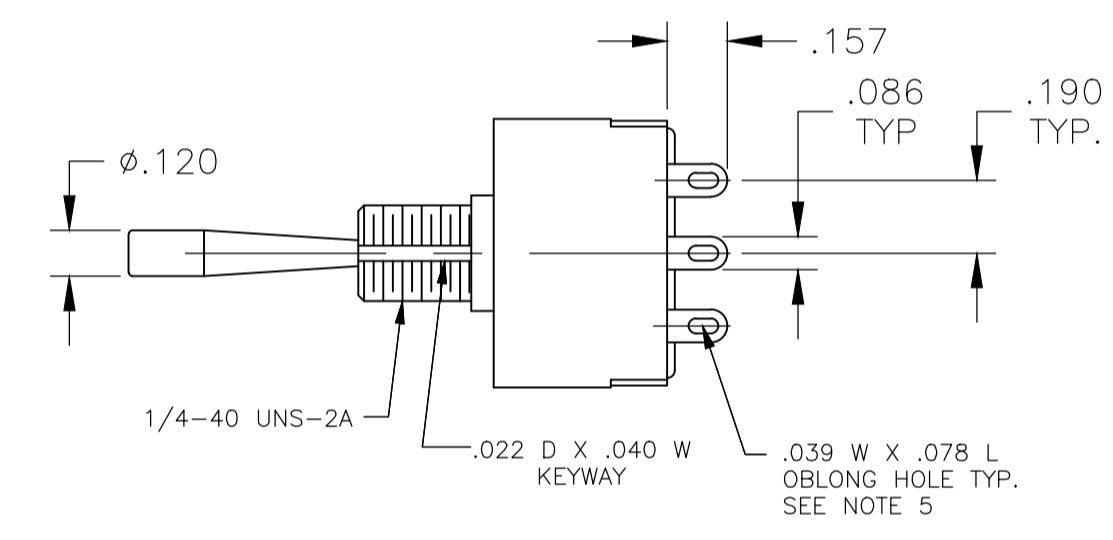

WIRE LUG TERMINAL

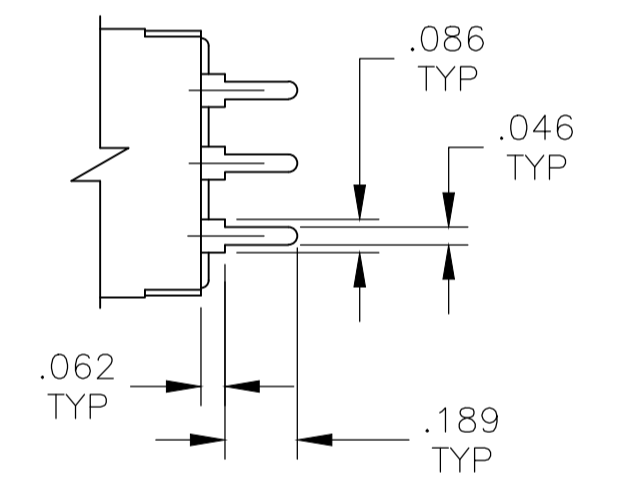

PC TERMINAL

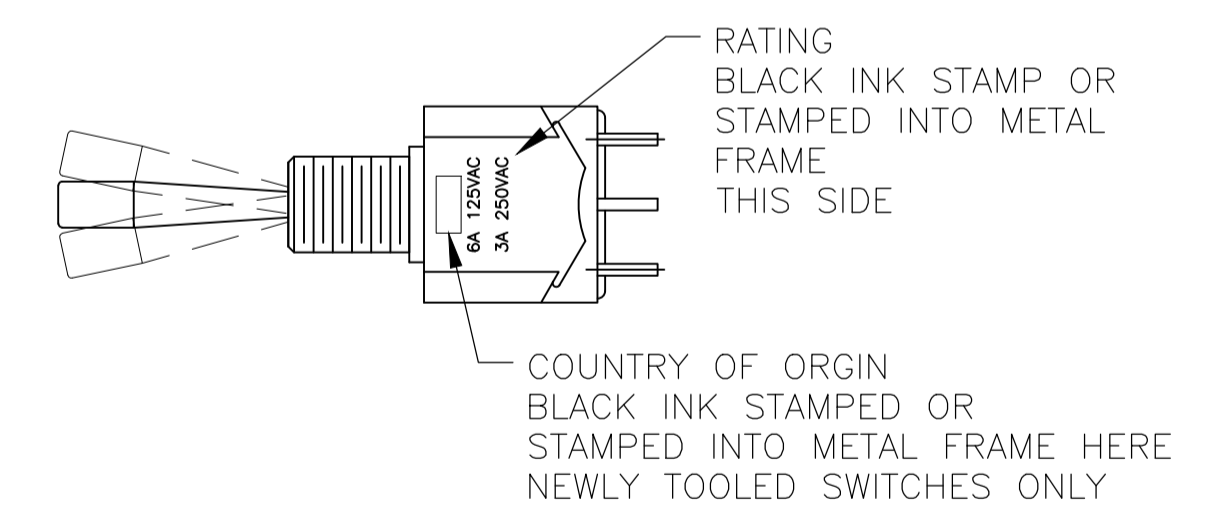

THIS DRAWING IS A CONTROLLED DOCUMENT.		DWN: M. BINNER 07APR04	TE Connectivity Ltd.
DIMENSIONS: INCHES		CHK: M. ZITTO 07APR04	
TOLERANCES UNLESS OTHERWISE SPECIFIED:		APVD: M. ZITTO 07APR04	NAME: TOGGLE SWITCH, MTB SERIES VERTICAL MOUNT
0 PLC ± -	1 PLC ± -	PRODUCT SPEC	SIZE: A1
2 PLC ± -	3 PLC ± .005	APPLICATION SPEC	CAGE CODE: 6-1437558-2
4 PLC ± -	ANGLES ± -	WEIGHT	DRAWING NO: 00779
MATERIAL: -	FINISH: -	CUSTOMER DRAWING	RESTRICTED TO: -
		SCALE: 1:1	SHEET: 3 OF 3
		REV: C4	