

THIS DRAWING IS UNPUBLISHED. RELEASED FOR PUBLICATION  
 © COPYRIGHT BY TYCO ELECTRONICS CORPORATION. ALL INTERNATIONAL RIGHTS RESERVED.

LOC	DIST	REVISIONS					
		P	LTR	DESCRIPTION	DATE	DWN	APVD
G	14		H1	REVISED PER ECR-09-009100	28APR09	HMR	TM

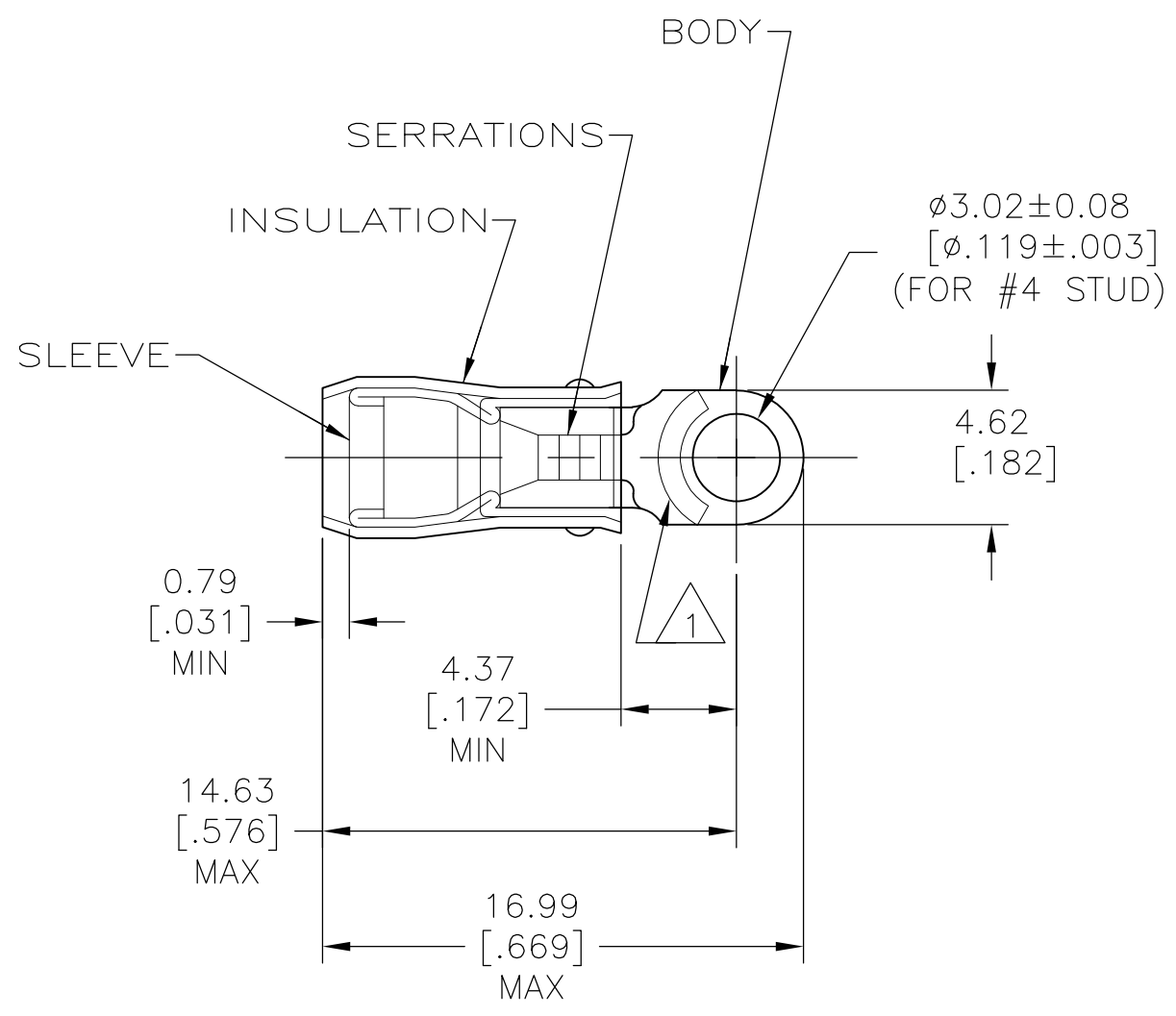

<b>AMP</b> WIRE RANGE	E13288	LR7189 Certified
22-16 AWG SOLID OR STRANDED	22-16 AWG SOLID OR STRANDED	22-16 AWG SOLID OR STRANDED

- 1 STAMP AMP 22-18\* APPROX AS SHOWN  
22-16 TERMINALS ARE STAMPED 22-18 IN  
ACCORDANCE WITH MILITARY SPEC MIL-T-7928  
COMMERCIAL WIRE RANGE IS 22-16
- 2 WIRE INSUL DIA, 2.67-3.56 [.105-.140]
- 3 TONGUE MATERIAL THK, 0.79±0.05 [.031±.002]

100	LOOSE PIECE, BOX	8-320882-1
5000	ON TAPE, REEL	2-320882-1
1000	LOOSE PIECE	320882
QTY	PACKAGE TYPE	PART NO

AMP INCORPORATED CUSTOMER SERVICE SYSTEM		MAX RECOMMENDED OPERATING TEMPERATURE: 105° C [221° F]	THIS DRAWING IS A CONTROLLED DOCUMENT.		DWN M ELLIS 16JUN95	Tyco Electronics Corporation Harrisburg, PA 17105-3608				
FOR ADDITIONAL PRODUCT INFORMATION OR COPIES OF DRAWINGS AND TECHNICAL DOCUMENTS	PRODUCT INFORMATION CENTER 1-800-522-6752		VOLTAGE RATING: 300 V MAX -	DIMENSIONS: mm [INCHES]	TOLERANCES UNLESS OTHERWISE SPECIFIED:				CHK C PRESNELL 16JUN95	NAME TERMINAL, RING TONGUE, PIDG TM WIRE SIZE, 22-16 AWG
FOR APPLICATION TOOLING INFORMATION	TOOLING ASSISTANCE CENTER 1-800-722-1111	CIRCULAR MIL AREA: 0.26mm <sup>2</sup> -1.65mm <sup>2</sup> [509-3260]		0 PLC ± - 1 PLC ± - 2 PLC ± 0.20[.008] 3 PLC ± - 4 PLC ± - ANGLES ± -	APVD N BIRCH 16JUN95	PRODUCT SPEC UL 486A	SIZE	CAGE CODE	DRAWING NO	RESTRICTED TO
FOR ORDER ENTRY	1-800-526-5142			MATERIAL BODY,SLV,COPPER PER ASTM-B-152 INSUL, NYLON, COLOR, RED	FINISH BODY & SLV,TIN PLATE PER ASTM-B-545			A3	00779	G-320882
					CUSTOMER DRAWING		SCALE	SHEET	REV	
							4:1	1 OF 1	H1	