

Complete Data Sheet available via web, Harris' home page: <http://www.semi.harris.com> or via Harris AnswerFAX, see Section 17

August 1997

**3³/₄ Digit,
Autorangeing Multimeter**

Features

- 13 Ranges - ICL7139
 - 4 DC Voltage 400mV, 4V, 40V, 400V
 - 1 AC Voltage 400V
 - 4 DC Current 4mA, 40mA, 400mA, 4A
 - 4 Resistance 4kΩ, 40kΩ, 400kΩ, 4MΩ
- 18 Ranges - ICL7149
 - 4 DC Voltage 400mV, 4V, 40V, 400V
 - 2 AC Voltage with Optional AC Circuit
 - 4 DC Current 4mA, 40mA, 400mA, 4A
 - 4 AC Current with Optional AC Circuit
 - 4 Resistance 4kΩ, 40kΩ, 400kΩ, 4MΩ
- Autorangeing - First Reading is Always on Correct Range
- On-Chip Duplex LCD Display Drive Including Three Decimal Points and 11 Annunciators
- No Additional Active Components Required
- Low Power Dissipation - Less than 20mW - 1000 Hour Typical Battery Life
- Display Hold Input
- Continuity Output Drives Piezoelectric Beeper
- Low Battery Annunciator with On-Chip Detection
- Guaranteed Zero Reading for 0V Input on All Ranges

Description

The Harris ICL7139 and ICL7149 are high performance, low power, auto-ranging digital multimeter ICs. Unlike other autorangeing multimeter ICs, the ICL7139 and ICL7149 always display the result of a conversion on the correct range. There is no "range hunting" noticeable in the display. The unit will autorange between the four different ranges. A manual switch is used to select the 2 high group ranges. DC current ranges are 4mA and 40mA in the low current group, and 400mA and 4A in the high current group. Resistance measurements are made on 4 ranges, which are divided into two groups. The low resistance ranges are 4/40kΩ. The high resistance ranges are 0.4/4MΩ. Resolution on the lowest range is 1Ω.

Ordering Information

PART NUMBER	TEMP. RANGE (°C)	PACKAGE	PKG. NO.
ICL7139CPL	0 to 70	40 Ld PDIP	E40.6
ICL7149CPL	0 to 70	40 Ld PDIP	E40.6
ICL7149CM44	0 to 70	44 Ld MQFP	Q44.10x10

Pinouts

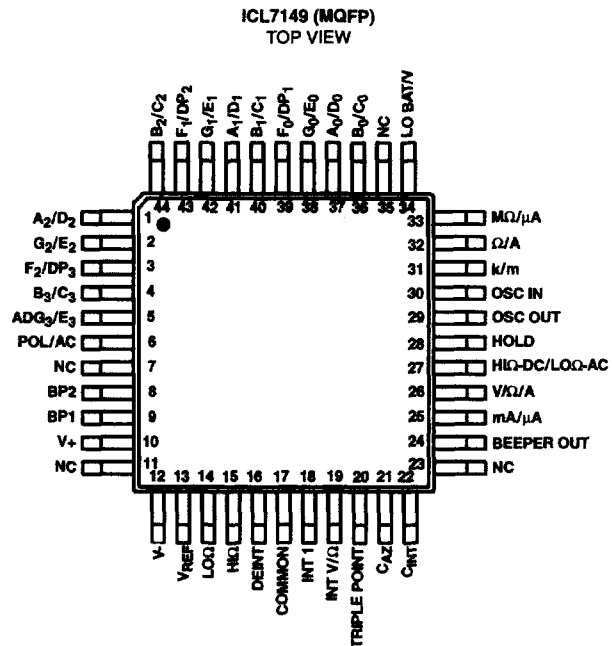
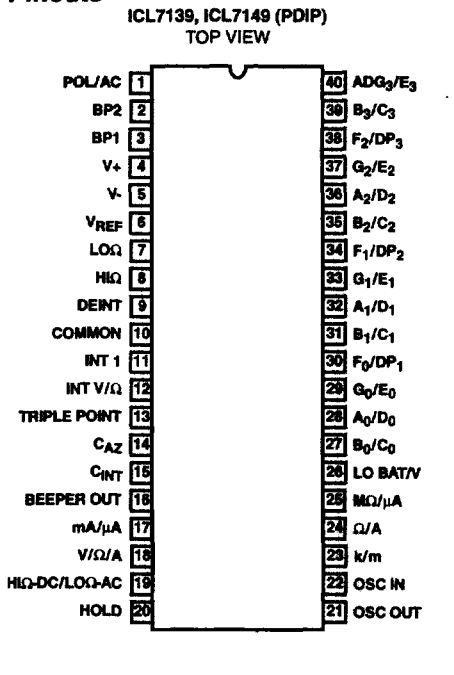

3
A/D CONVERTERS
DISPLAY