

## Absolute maximum ratings

( $T_a=25^\circ\text{C}$ )

Symbol	Ratings	Unit
$V_{CB0}$	-60	V
$V_{CEO}$	-60	V
$V_{EBO}$	-6	V
$I_c$	-3	A
$I_{CP}$	-6 (PW $\leq$ 1ms, Du $\leq$ 50%)	A
$I_B$	-0.5	A
$I_F$	-6 (PW $\leq$ 0.5ms, Du $\leq$ 25%)	A
$I_{FSM}$	-8 (PW $\leq$ 10ms, Single pulse)	A
$V_R$	100	V
$P_T$	4 ( $T_a=25^\circ\text{C}$ )	W
	20 ( $T_c=25^\circ\text{C}$ )	
$T_j$	150	$^\circ\text{C}$
$T_{stg}$	-40 to +150	$^\circ\text{C}$

## Electrical characteristics

( $T_a=25^\circ\text{C}$ )

Symbol	Specification			Unit	Conditions
	min	typ	max		
$I_{CB0}$			-10	$\mu\text{A}$	$V_{CB}=-60\text{V}$
$I_{EBO}$			-10	mA	$V_{EB}=-6\text{V}$
$V_{CEO}$	-60			V	$I_c=-10\text{mA}$
$h_{FE}$	2000	5000	12000		$V_{CE}=-4\text{V}$ , $I_c=-2\text{A}$
$V_{CE(sat)}$			-1.5	V	$I_c=-2\text{A}$ , $I_B=-4\text{mA}$
$V_{BE(sat)}$			-2.0	V	

## Diode for flyback voltage absorption

( $T_a=25^\circ\text{C}$ )

Symbol	Specification			Unit	Conditions
	min	typ	max		
$V_R$	100			V	$I_R=10\mu\text{A}$
$V_F$			1.2	V	$I_F=1\text{A}$
$I_R$			10	$\mu\text{A}$	$V_R=100\text{V}$
$t_{rr}$		100		ns	$I_F=\pm 100\text{mA}$

## Equivalent circuit diagram

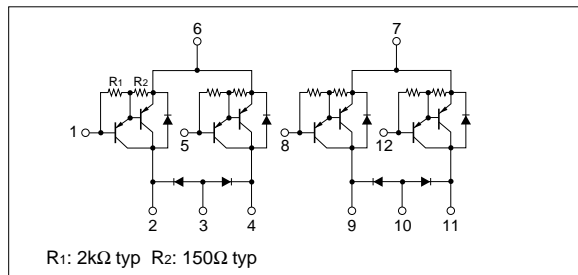

## Characteristic curves

$I_c$ - $V_{CE}$  Characteristics (Typical)

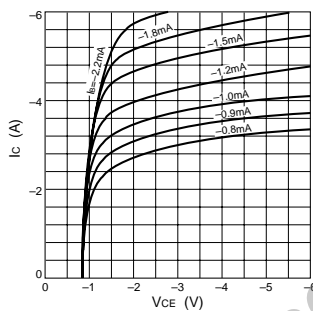

$h_{FE}$ - $I_c$  Characteristics (Typical)

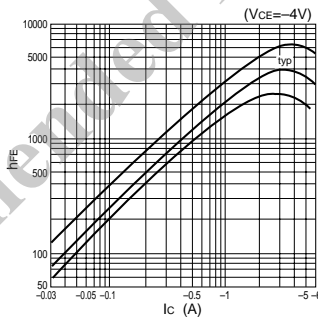

$h_{FE}$ - $I_c$  Temperature Characteristics (Typical)

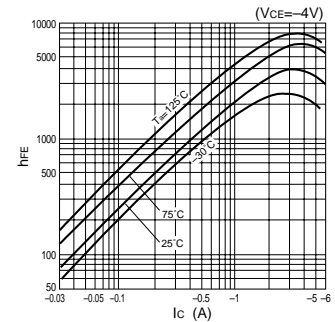

$V_{CE(sat)}$ - $I_c$  Temperature Characteristics (Typical)

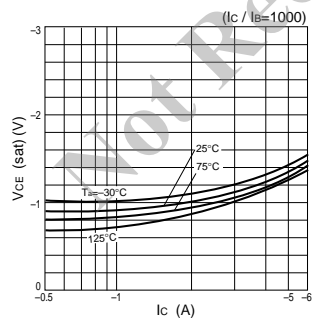

$V_{CE(sat)}$ - $I_B$  Characteristics (Typical)

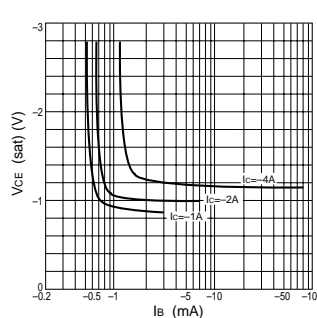

$I_c$ - $V_{BE}$  Temperature Characteristics (Typical)

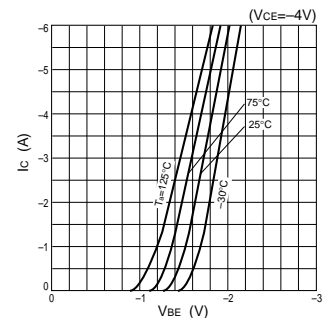

$\theta_{j-a}$ -PW Characteristics

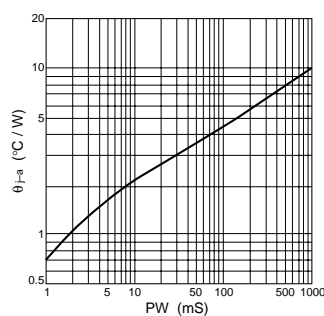

$P_T$ - $T_a$  Characteristics

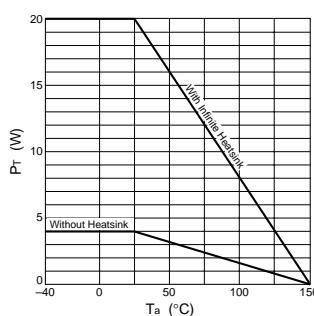

Safe Operating Area (SOA)

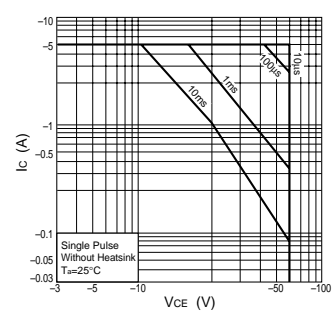

• SIP 8 (STA8Pin)

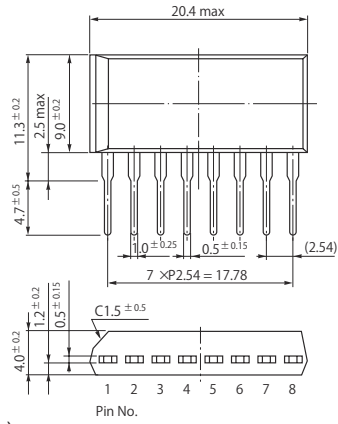

• SIP 10 (STA10Pin)

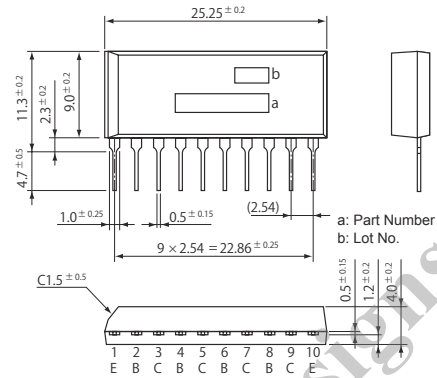

• SIP 12 (SMA12Pin)

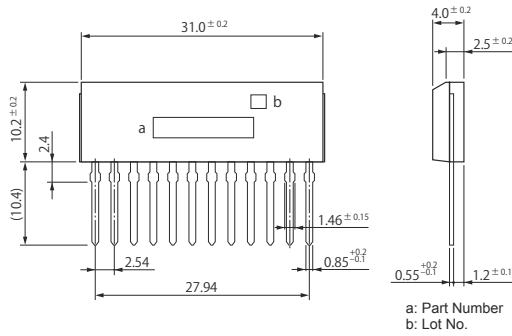

• SIP 15 (SMA15Pin)

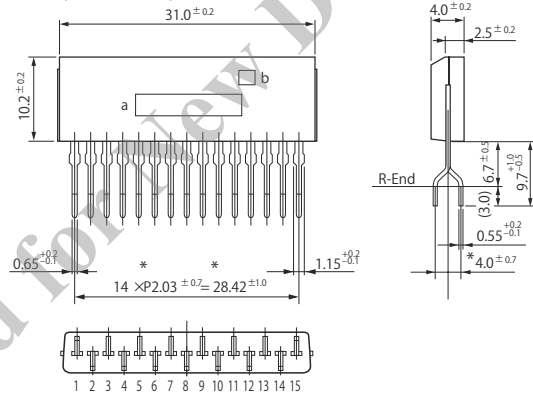

• SIP 12 with Fin (SLA12Pin)

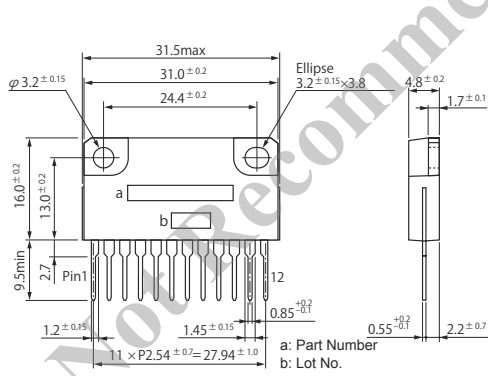

• SIP 15 with Fin (SLA15Pin)

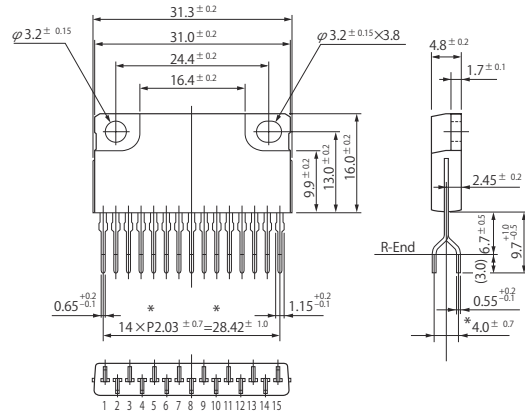

• SIP 21 with Fin (SLA21Pin)

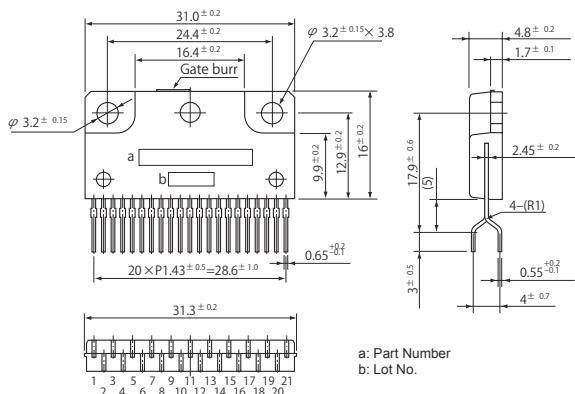

(Unit:mm)