

ITEM NO.	FORM	WIRE GAGE	QUANTITY PER REEL	DIM. "B"	DIM. "C"	DIM. "D"	DIM. "E"	DIM. "F"	DIM. "G"
44476-1111	CHAIN	18-20 GA.	4,000	.142±.012 (3.60±0.30)	.177±.016 (4.50±0.40)	.035 (0.90)	.075±.012 (1.90±0.30)	.091±.016 (2.30±0.40)	.020 (0.50)
44476-1112	LOOSE								
44476-3111	CHAIN	16 GA.	4,000	.142±.012 (3.60±0.30)	.177±.016 (4.50±0.40)	.035 (0.90)	.091±.012 (2.30±0.30)	.106±.016 (2.70±0.40)	.024 (0.60)
44476-3112	LOOSE								

LEGEND:

44476 - * * 1 *

BASE NO. _____

WIRE GAGE
1 = 18-20 AWG
3 = 16 AWG

PLATING
SEE NOTE 2

CHAIN OR LOOSE
"1" = CHAIN
"2" = LOOSE

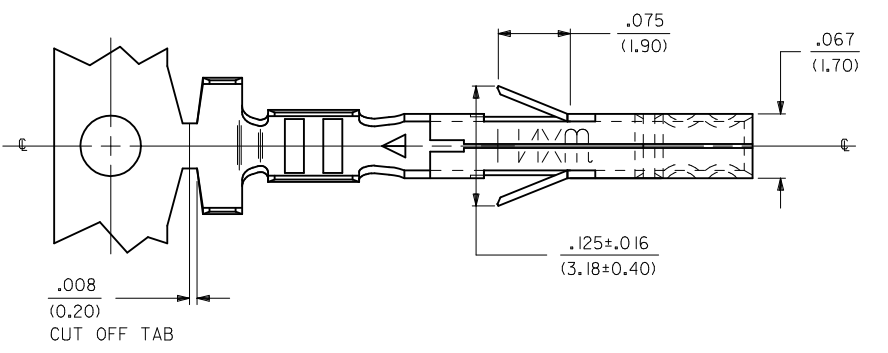

- NOTES:
- MATERIAL: COPPER ALLOY, .008/(.203) THICK.
 - FINISH:
 - *1 = POSTPLATE .000100/(.00254) MIN. BRIGHT TIN OVER .000050/(0.00127) MIN. NICKEL OVERALL.
 - *THE PRIMARY SHIPPING CARTON WILL BE LABELED "COMPLIANT TO RoHS DIRECTIVE 2002/95/EC AND ELV ANNEX II OF DIRECTIVE 2000/53/EC." CARTONS WITHOUT THIS LABEL MAY CONTAIN PRODUCT WITH TIN-LEAD PLATING.
 - PRODUCT SPECIFICATION AND PROCESSING PARAMETERS: SEE PS-44476-001.
 - PACKAGING SPECIFICATION: PK-44476-001 FOR CHAIN TERMINALS
PK-5556-003 FOR LOOSE TERMINALS
 - MATES WITH 44478 MALE TERMINAL AND 43810, 44068, 44472, 44473, 44474, 42404, 5569 AND 30070 SERIES CONNECTORS.
 - TERMINAL FOR USE WITH 5557, 30067 & 42474 SERIES HOUSINGS.
 - ITEM NUMBERS PRECEDED BY AN "X" IN THE CHART ARE NOT AVAILABLE.

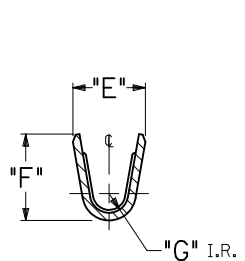
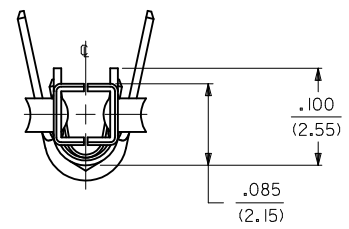
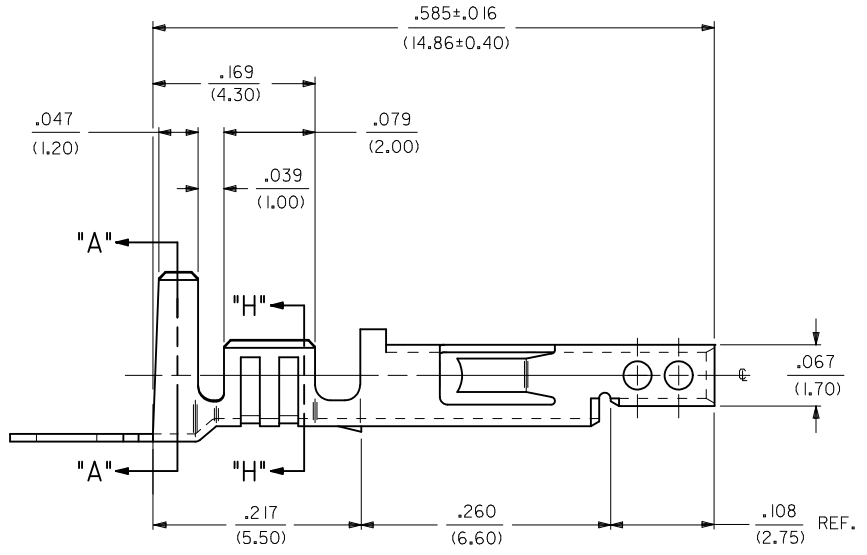

SECT. "H-H"

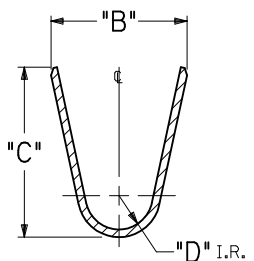

SECT. "A-A"

CHANGED NOTE 4 EC NO: UCP2010-0471 DRWN: JAGUILAR 2009/12/23 CHKD: J.BELL 2009/12/23 APPR: F.S.MITH 2009/12/28 REV: D2	QUALITY SYMBOLS ▽=0 ▽=0	GENERAL TOLERANCES (UNLESS SPECIFIED) <table border="1"> <thead> <tr> <th></th> <th>mm</th> <th>INCH</th> </tr> </thead> <tbody> <tr> <td>4 PLACES</td> <td>± .010</td> <td>± .0004</td> </tr> <tr> <td>3 PLACES</td> <td>± .010</td> <td>± .0004</td> </tr> <tr> <td>2 PLACES</td> <td>± 0.25</td> <td>± .010</td> </tr> <tr> <td>1 PLACE</td> <td>± 0.38</td> <td>± .015</td> </tr> </tbody> </table>		mm	INCH	4 PLACES	± .010	± .0004	3 PLACES	± .010	± .0004	2 PLACES	± 0.25	± .010	1 PLACE	± 0.38	± .015	DIMENSION STYLE IN/MM	SCALE 10:1	DESIGN UNITS METRIC	THIRD ANGLE PROJECTION
		mm	INCH																		
	4 PLACES	± .010	± .0004																		
	3 PLACES	± .010	± .0004																		
2 PLACES	± 0.25	± .010																			
1 PLACE	± 0.38	± .015																			
DRAWN BY: GEP DATE: 1992/09/14 CHECKED BY: R.J.F. DATE: 1992/09/14 APPROVED BY: R.J.F. DATE: 1992/09/14		MATERIAL NO. SEE CHART		DOCUMENT NO. SD-44476-****		SHEET NO. 1 OF 1															
DRAFT WHERE APPLICABLE MUST REMAIN WITHIN DIMENSIONS		SIZE C		THIS DRAWING CONTAINS INFORMATION THAT IS PROPRIETARY TO MOLEX INCORPORATED AND SHOULD NOT BE USED WITHOUT WRITTEN PERMISSION																	