

LOC	DIST	REVISIONS			
CM	00	REV	DESCRIPTION	DATE	BY
		D2	REVISED PER ECO-13-004136	15MAR13	DZ YHM

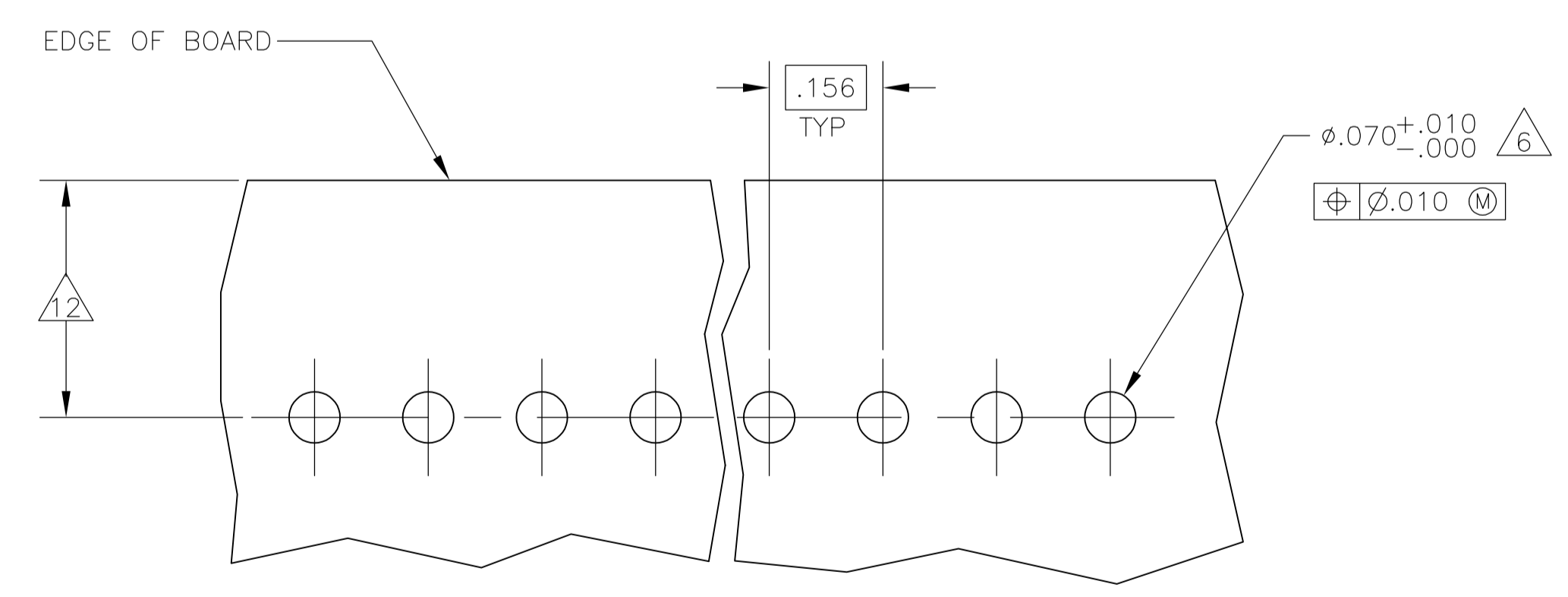
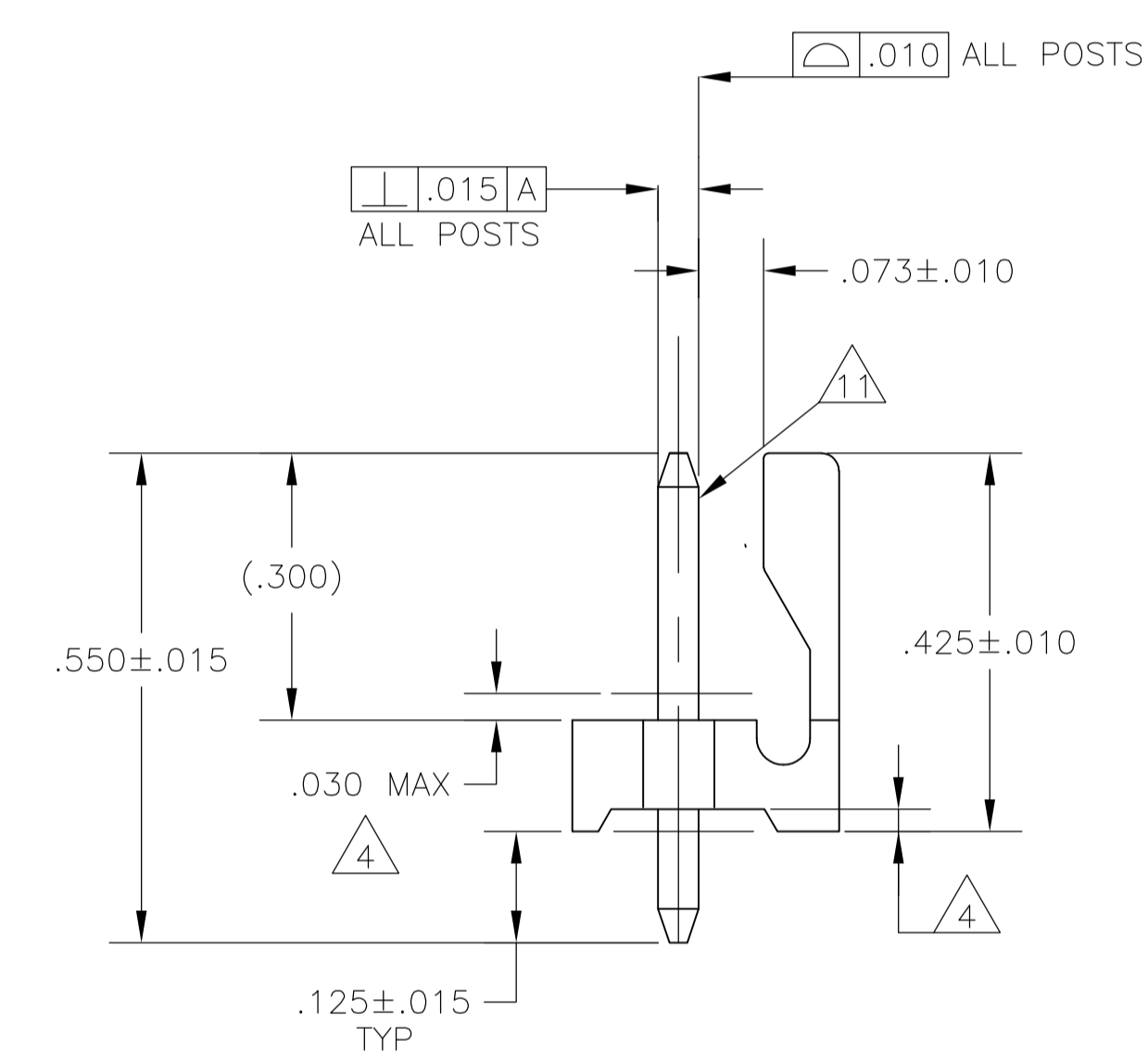
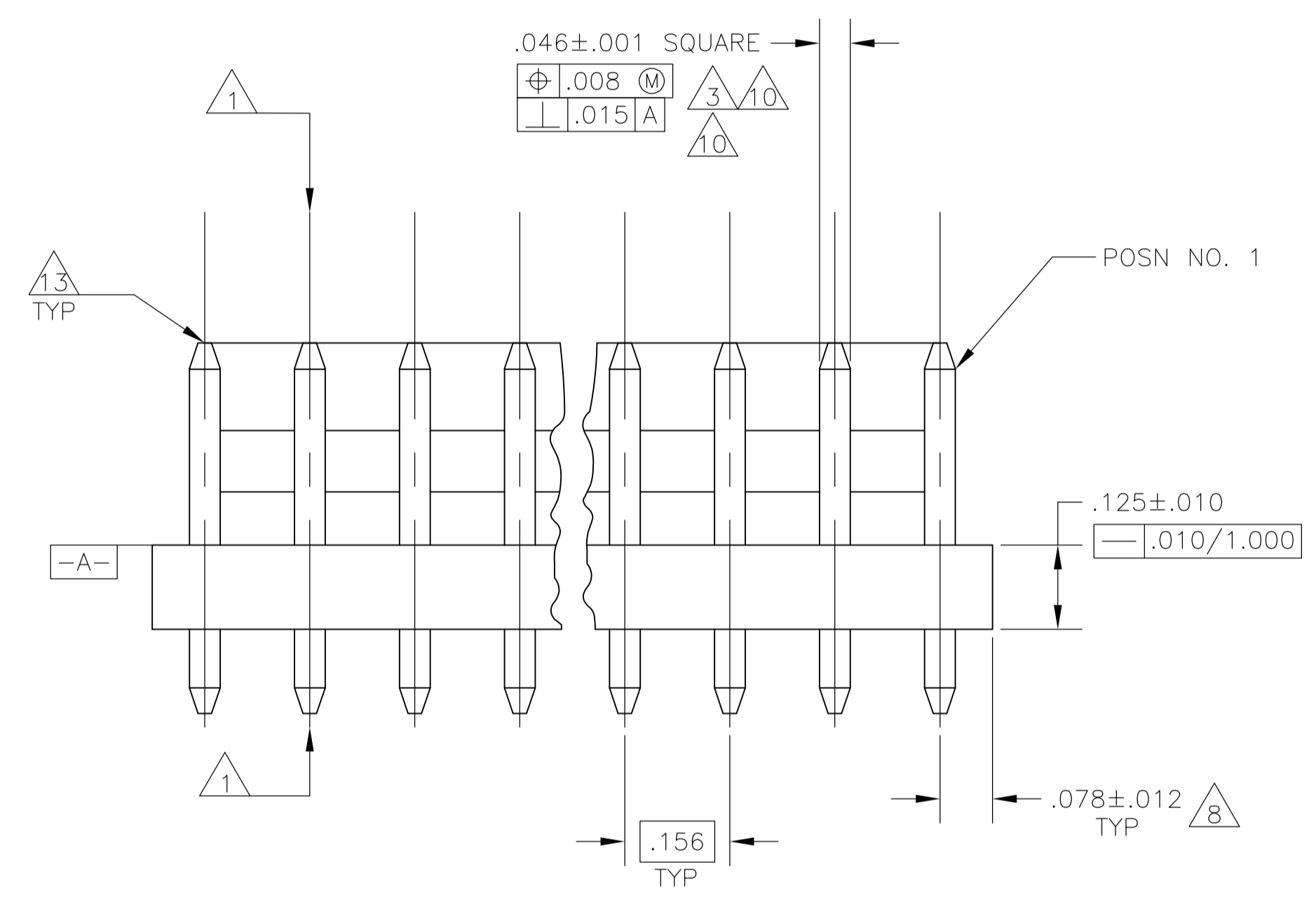
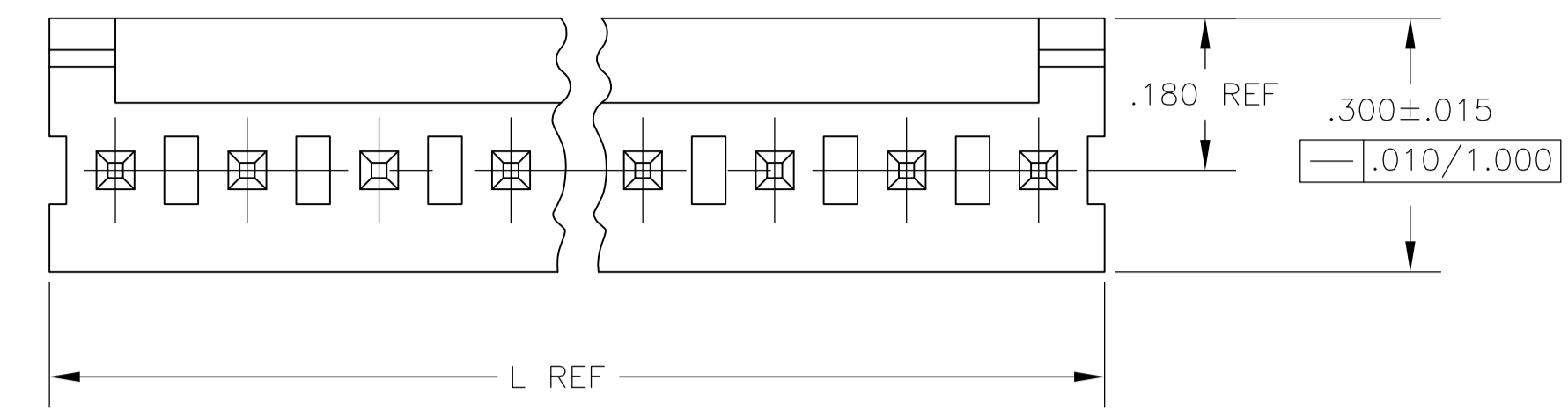

RECOMMENDED MOUNTING HOLE PATTERN FOR .063 THICK P.C. BOARD

- 1 POST TO WITHSTAND 13 NEWTONS (3LBS.) MIN. AXIAL FORCE IN BOTH DIRECTIONS SHOWN WITHOUT DISLODGING.
- 2 TOLERANCES APPLY TO SOLDER SIDE OF BOARD.
- 3 MEASURED AT SURFACE -A-
- 4 PLASTIC FLASH PERMITTED IN THIS AREA.
- 5 PARTS COMPLY WITH AMP SOLDERABILITY SPEC. NO. 109-11-2.
- 6 ONE HOLE MAY BE UNDERSIZED (.065/.060 DIA.) FOR ASSEMBLY RETENTION DURING WAVE SOLDERING.
- 7 MATERIAL: HEADER-THERMOPLASTIC POLYESTER GLASS-FILLED 94V-0 (NATURAL) POST-COPPER ALLOY (TIN PLATED)
- 8 COORDINATE DIMENSION APPLIES FROM CENTER OF ACTUAL FEATURE.
- 9 PLASTIC BURRS CAUSED BY CUT-OFF TOOLING ARE PERMITTED WITHIN THE MAXIMUM TOLERANCE ENVELOPE.
- 10 POST TO BE MEASURED WHEN STRIP IS HELD FLAT.
- 11 POST MUST WITHSTAND TWO 90 BENDS AGAINST EXTRUSION WITHOUT BREAKING.
- 12 DIMENSION SHOULD BE .175 MIN WHEN MATING WITH A MTA 156 CONNECTOR ASSEMBLY OR A SL-156 CONNECTOR ASSEMBLY.
- 13 PIN BURR OF .005 MAX. VERTICAL AND .003 MAX. HORIZONTAL PERMITTED AT POST TIPS ON BOTH ENDS.

INCHES	MILLIMETERS	INCHES	MILLIMETERS
.068	1.73	1.000	25.40
.065	1.65	.550	13.97
.063	1.60	.450	11.43
.060	1.52	.425	10.80
.045	1.14	.400	10.16
.030	0.76	.300	7.62
.015	0.38	.180	4.57
.012	0.30	.175	4.45
.010	0.25	.156	3.96
.008	0.20	.125	3.18
.005	0.13	.078	1.98
.003	0.08	.073	1.85
.001	0.03	.070	1.78
[IN]	MM	[IN]	MM

CONVERSION TABLE

95.06	3.744	24	2-1744194-4
91.10	3.588	23	2-1744194-3
87.14	3.432	22	2-1744194-2
83.18	3.276	21	2-1744194-1
79.22	3.120	20	2-1744194-0
75.26	2.964	19	1-1744194-9
71.30	2.808	18	1-1744194-8
67.34	2.652	17	1-1744194-7
63.38	2.496	16	1-1744194-6
59.42	2.340	15	1-1744194-5
55.46	2.184	14	1-1744194-4
51.50	2.028	13	1-1744194-3
47.54	1.872	12	1-1744194-2
43.58	1.716	11	1-1744194-1
39.62	1.560	10	1-1744194-0
35.66	1.404	9	1744194-9
31.70	1.248	8	1744194-8
27.74	1.092	7	1744194-7
23.77	.936	6	1744194-6
19.81	.780	5	1744194-5
15.85	.624	4	1744194-4
11.89	.468	3	1744194-3
7.93	.312	2	1744194-2
MM	IN	NO. OF POSITIONS	ASSEMBLY PART NO.

THIS DRAWING IS A CONTROLLED DOCUMENT.

APPROVED: K. WHITAKER, D. ROSSI, D. ROSSI

DATE: 09DEC05, 09DEC05, 09DEC05

NAME: MTA-156 HEADER ASSEMBLY, FRICTION LOCK, STRAIGHT .045 SQUARE POST, TIN PLATED

SIZE: A1, WEIGHT: 00779, DRAWING NO: 1744194

CUSTOMER DRAWING, SCALE: 5:1, SHEET: 1 OF 1, REV: D2