

High Efficiency Single Inductor Buck-Boost Converter

Purpose

The startup voltage of the RT6154B is around 1.8V to 5.5V. When Input voltage is greater than 1.8V in light Load and heavy Load, the RT6154B feedback loop is internally compensated for both Buck and Boost operation and it provides seamless transition between Buck and Boost modes and optimal transient response.

Table of Contents

Purpose	1
Introduction.....	2
Applications	2
Key Performance Summary Table	2
Bench Test Setup Conditions	3
Schematic, Bill of Materials & Board Layout	5
More Information.....	8
Important Notice for Richtek Evaluation Board	8

Introduction

General Product Information

RT6154B is a high efficiency single inductor Buck-Boost Converter which can operate with wide input voltage such as battery which is higher or lower than the output voltage and it can supply the load current up to 4A. The maximum average current in the switches is limited to a typical value of 5A.

The RT6154B feedback loop is internally compensated for both Buck and Boost operation and it provides seamless transition between Buck and Boost modes and optimal transient response. The RT6154B operates at 2.4MHz typical switching frequency in full synchronous operation.

The RT6154B operates in Pulse Skipped Modulation (PSM) mode for increasing efficiency during low power RF transmission modes. The Power Save Mode can be disabled, forcing the RT6154B to operate at a fixed switching frequency. The RT6154B output voltage is fixed internally to 3.3V.

Product Feature

- Operates from a Single Li-ion Cell : 1.8V to 5.5V
- Fixed Output Voltage 3.3V
- PSM Operation
- 3A Maximum Load Capability for $V_{IN} > 3.6V$, $V_{OUT} = 3.3V$
- 2.4MHz (typ.) Switching Frequency
- Up to 96% Efficiency
- Input Over Current Limit
- Internal Compensation

Applications

- Cellular Phones
- Portable Hard Disk Drives
- PDA

Key Performance Summary Table

Key Features	Evaluation Board Number : PCB054_V1
Input Voltage Range	1.8V to 5.5V
Switching Frequency	2.4MHz
Max Output Current	4A
Output Voltage	Fixed 3.3V
Default Marking & Package Type	RT6154BGQW, WDFN-14AL 4x3

Bench Test Setup Conditions

Headers Description and Placement

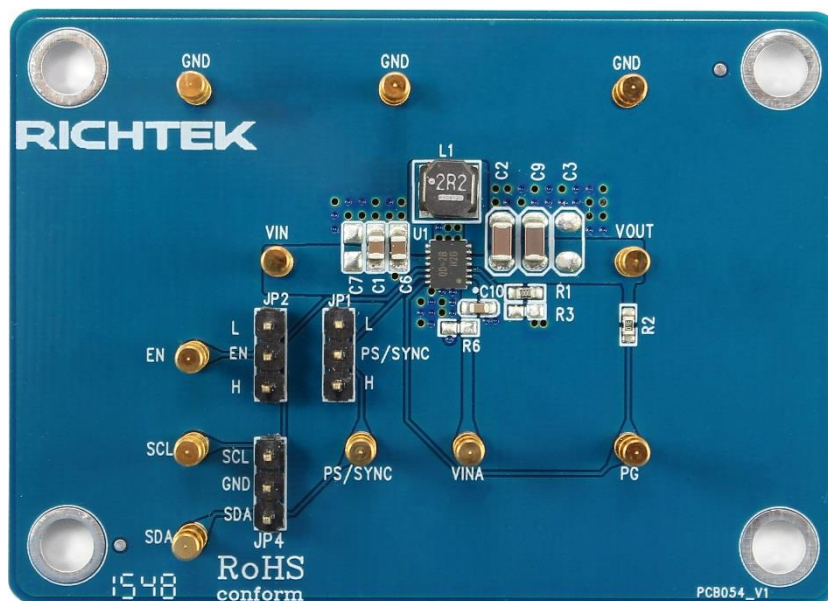

Please carefully inspect the EVB IC and external components, comparing them to the following Bill of Materials, to ensure that all components are installed and undamaged. If any components are missing or damaged during transportation, please contact the distributor or send e-mail to evb_service@richtek.com

Test Points

The EVB is provided with the test points and pin names listed in the table below.

Test point/ Pin name	Signal	Comment (expected waveforms or voltage levels on test points)
VINA	Internal Driver voltage	Analog VIN
GND	Analog Ground	Analog Ground.
FB	Reference voltage	Voltage feedback of adjustable versions, must be connected to VOUT on fixed output voltage versions.
EN	Enable Control	BUCK-boost converter output.
LX1	Switch Frequency	First switching node
LX2	Switch Frequency	Second switching node
VIN	Input voltage	Power VIN
EN	Enable Control	Enable input (1 enabled, 0 disabled), must not be left open.
PS/SYNC	Enable/Disable Control Input	Enable/disable power save mode (1 disabled, 0 enabled, clock signal for synchronization), must not be left open.
PG	Power Good Indicator Output.	Output power good (1 good, 0 failure; open drain)
PGND	Power Ground	PGND

Power-up & Measurement Procedure

1. Connect input power ($1.8V < V_{IN} < 5.5V$) to VIN test pin.
2. EN short to VIN, PS/SYNC is Low or High, see SW switch is working.
3. Observe the output voltage is correct.

Operating Guideline

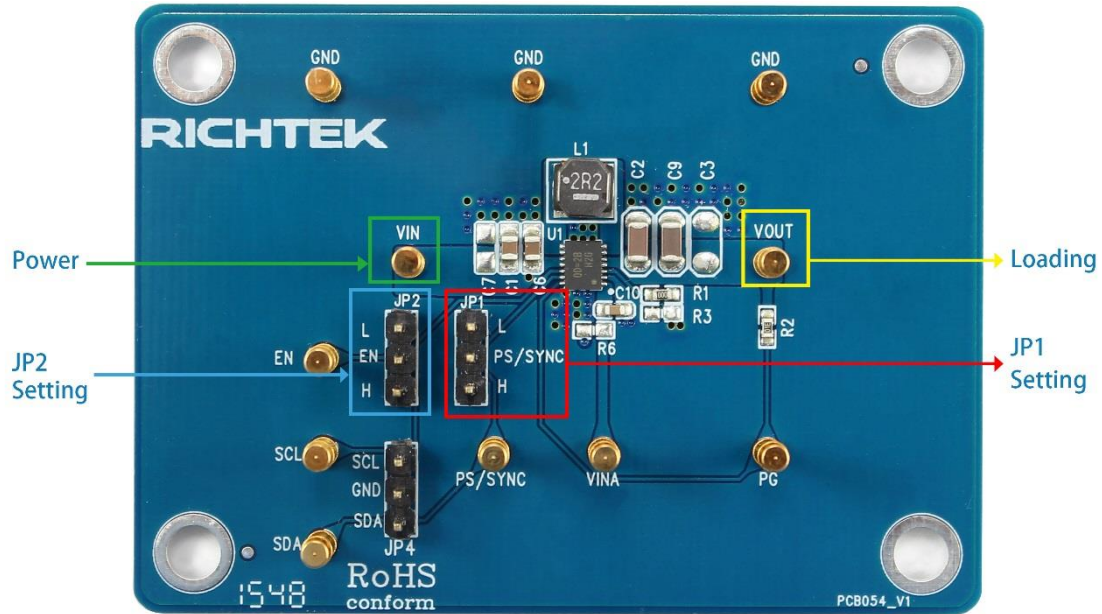

JP1 Setting

PS/SYNC Pin	Operate Mode
VIN	PWM
GND	PSM

JP2 Setting

Enable Pin (EN)	Function
VIN	Turn on
GND	Turn off

VOUT Setting

$V_{OUT} = 3.3V$

Schematic, Bill of Materials & Board Layout

EVB Schematic Diagram

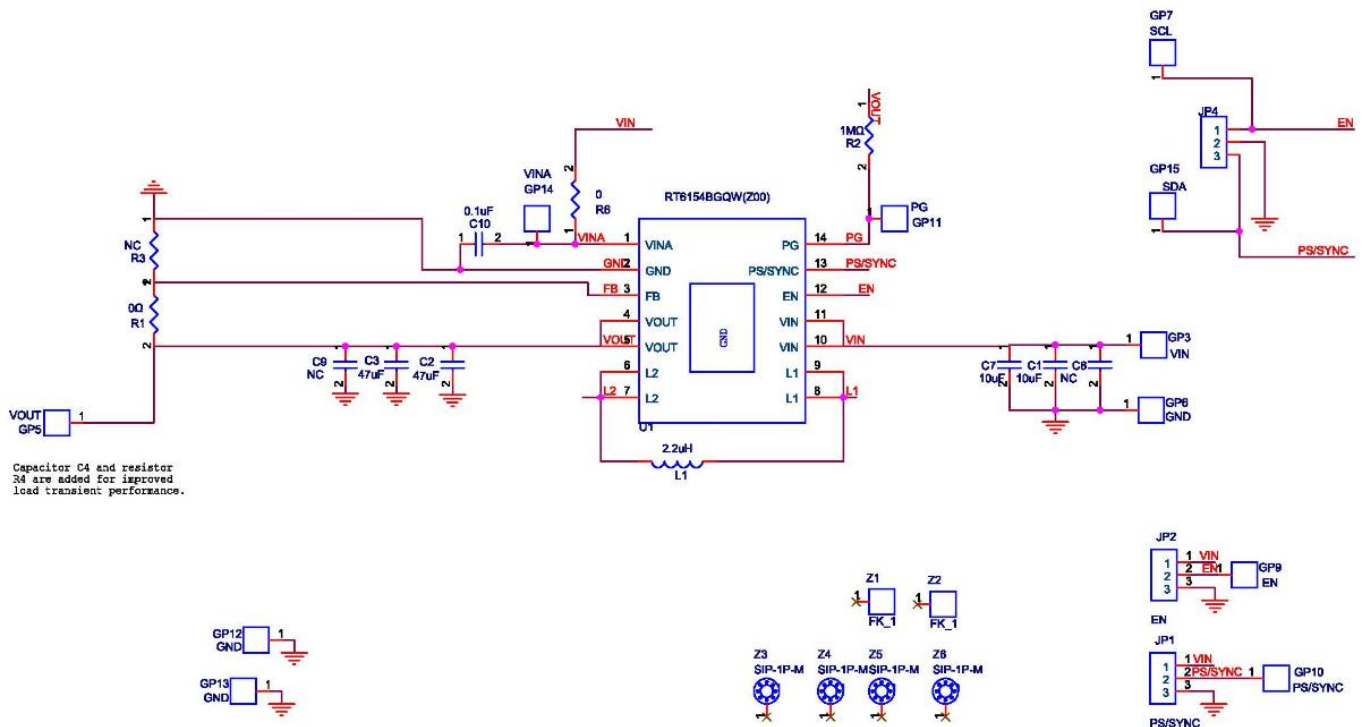

Bill of Materials

Reference	Qty	Part Number	Description	Package	Manufacture
C1	1	C2012X5R1C106KTHN	10 μ F	0805	TDK
C2	1	C3216X5R0J476MT000N	47 μ F	1206	TDK
C3	1	C3216X5R0J476MT000N	47 μ F	1206	TDK
C6	1		NC		
C7	1	C2012X5R1C106KTHN	10 μ F	0805	TDK
C9	1		NC		
C10	1	C1608X7R1E104KT000N	0.1 μ F	0603	TDK
GP3	1		VIN		
GP5	1		VOUT		
GP6, GP12, GP13	3		GND		
GP7	1		SCL		
GP9	1		EN		
GP10	1		PS/SYNC		
GP11	1		PG		
GP14	1		VINA		
GP15	1		SDA		

Reference	Qty	Part Number	Description	Package	Manufacture
JP1	1		PS/SYNC		
JP2	1		EN		
JP4	1		SIP-3P		
L1	1	NRS5040T2R2NMGJ	2.2 μ H	5040	TAIYO YUDEN
R1	1	0603 1M00 1%	0 Ω	0603	Walsin
R2	1	0603 1M00 1%	1M Ω	0603	Walsin
R3	1		NC		
R6	1		NC		
U1	1	RT6154BGQW	Buck-Boost Converter	WDFN-14AL 4x3	RICHTEK
Z1, Z2	2		FK_1		
Z3, Z4, Z5, Z6	4		SIP-1P-M		

PCB Layout

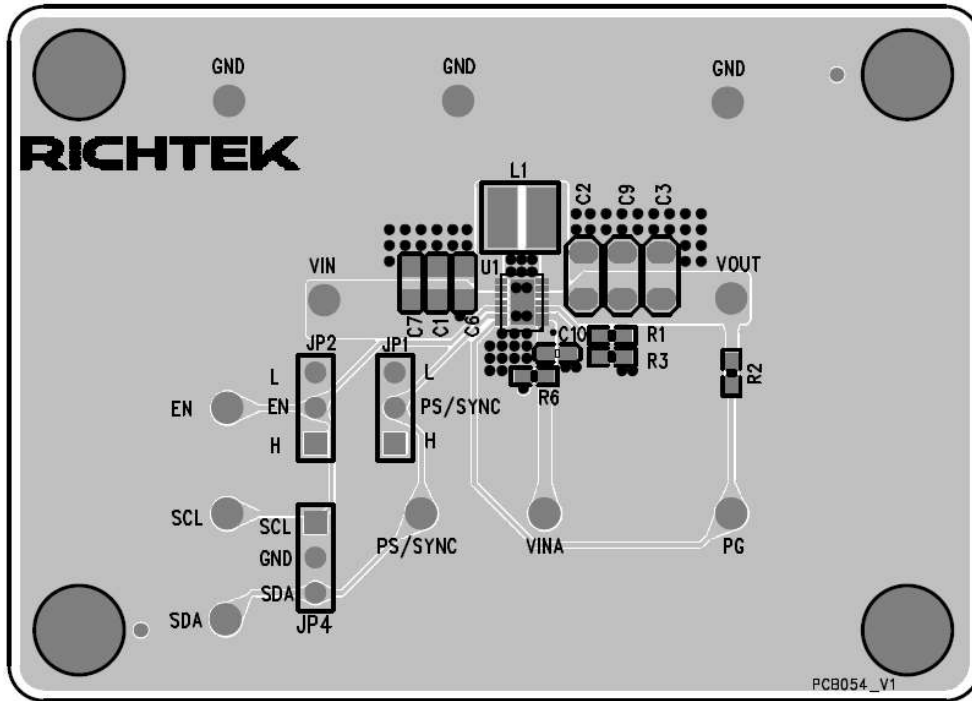

Top View

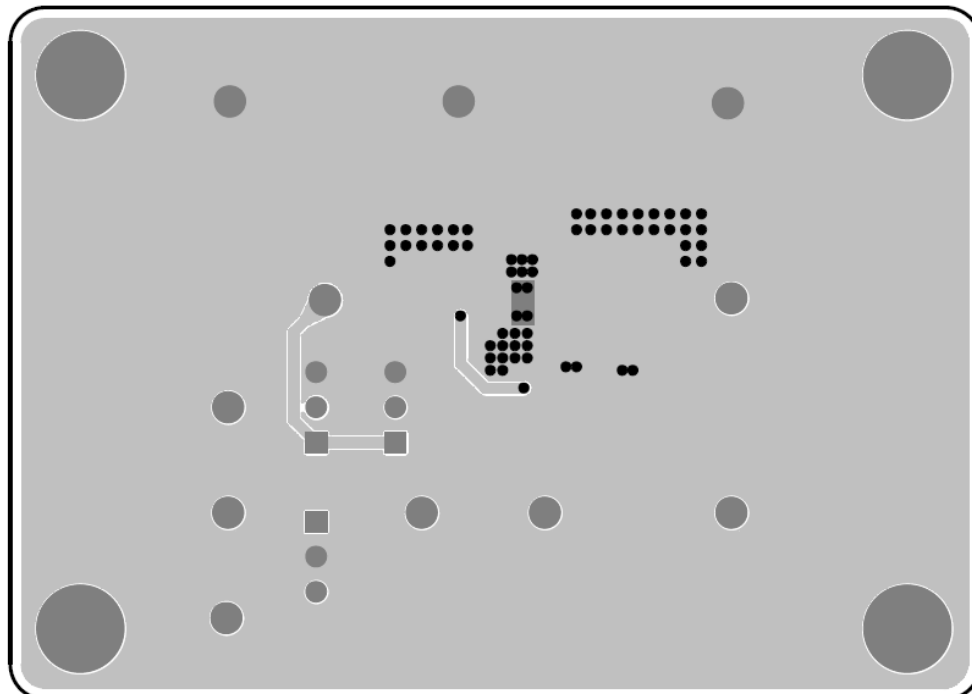

Bottom View

More Information

For more information, please find the related datasheet or application notes from Richtek website <http://www.richtek.com>.

Important Notice for Richtek Evaluation Board

THIS DOCUMENT IS FOR REFERENCE ONLY, NOTHING CONTAINED IN THIS DOCUMENT SHALL BE CONSTRUED AS RICHTEK'S WARRANTY, EXPRESS OR IMPLIED, UNDER CONTRACT, TORT OR STATUTORY, WITH RESPECT TO THE PRESENTATION HEREIN. IN NO EVENT SHALL RICHTEK BE LIABLE TO BUYER OR USER FOR ANY AND ALL DAMAGES INCLUDING WITHOUT LIMITATION TO DIRECT, INDIRECT, SPECIAL, PUNITIVE OR CONSEQUENTIAL DAMAGES.