

Description

The 74AHC1G09 is a single 2-input positive AND gate with an open drain output. The device is designed for operation with a power supply range of 2.0V to 5.5V. The open-drain output can be connected to other open drain outputs to implement active-low wired-OR or active-high wired-AND functions. The gate performs the positive Boolean function:

$$Y = A \cdot B \text{ or } Y = \overline{\overline{A} + \overline{B}}$$

A pull-up resistor is required to achieve a high output state.

Features

- Supply Voltage Range from 2.0V to 5.5V
- 8mA sink current at 5.0 V
- CMOS low power consumption
- Schmitt Trigger Action at All Inputs Make the Circuit Tolerant for Slower Input Rise and Fall Time.
- ESD Protection per JESD 22
 - Exceeds 200-V Machine Model (A115-A)
 - Exceeds 2000-V Human Body Model (A114-A)
 - Exceeds 1000-V Charged Device Model (C101C)
- Latch-Up Exceeds 100mA per JESD 78, Class II
- SOT25 and SOT353: Assembled with "Green" Molding Compound (no Br, Sb)
 - **Totally Lead-Free & Fully RoHS Compliant (Notes 1 & 2)**
 - **Halogen and Antimony Free. "Green" Device (Note 3)**

- Notes:
1. No purposely added lead. Fully EU Directive 2002/95/EC (RoHS) & 2011/65/EU (RoHS 2) compliant.
 2. See http://www.diodes.com/quality/lead_free.html for more information about Diodes Incorporated's definitions of Halogen- and Antimony-free, "Green" and Lead-free.
 3. Halogen- and Antimony-free "Green" products are defined as those which contain <900ppm bromine, <900ppm chlorine (<1500ppm total Br + Cl) and <1000ppm antimony compounds.

Pin Assignments

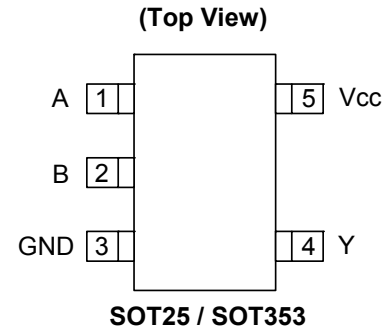

Applications

- General Purpose Logic
- Wide array of products such as:
 - PCs, networking, notebooks, netbooks, PDAs
 - Computer peripherals, hard drives, CD/DVD ROM
 - TV, DVD, DVR, set top box
 - Personal Navigation / GPS
 - MP3 players ,Cameras, Video Recorders

Pin Descriptions

Pin Name	Pin NO.	Function
A	1	Data Input
B	2	Data Input
GND	3	Ground
Y	4	Data Output
V _{CC}	5	Supply Voltage

Logic Diagram

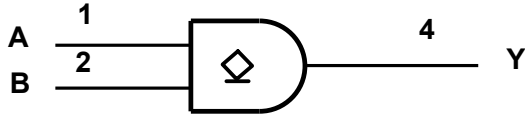

Functional Table

Inputs		Output
A	B	Y
H	H	Z
L	X	L
X	L	L

Absolute Maximum Ratings (Note 4) (@T_A = +25°C, unless otherwise specified.)

Symbol	Parameter	Rating	Unit
ESD HBM	Human Body Model ESD Protection	2	KV
ESD CDM	Charged Device Model ESD Protection	1	KV
ESD MM	Machine Model ESD Protection	200	V
V _{CC}	Supply Voltage Range	-0.5 to 6.5	V
V _I	Input Voltage Range	-0.5 to 6.5	V
V _O	Voltage applied to output in high or low state	-0.5 to V _{CC} +0.5	V
I _{IK}	Input Clamp Current V _I < 0	-20	mA
I _{OK}	Output Clamp Current (V _O < 0 or V _O > V _{CC})	±20	mA
I _O	Continuous output current (V _O = 0 to V _{CC})	±25	mA
I _{CC}	Continuous current through V _{CC}	50	mA
I _{GND}	Continuous current through GND	-50	mA
T _J	Operating Junction Temperature	-40 to +150	°C
T _{STG}	Storage Temperature	-65 to +150	°C

Note: 4. Stresses beyond the absolute maximum may result in immediate failure or reduced reliability. These are stress values and device operation should be within recommend values.

NEW PRODUCT

Recommended Operating Conditions (Note 5) (@T_A = +25°C, unless otherwise specified.)

Symbol	Parameter	Min	Max	Unit
V _{CC}	Operating Voltage	2.0	5.5	V
V _{IH}	High-Level Input Voltage	V _{CC} = 2V	1.5	V
		V _{CC} = 3V	2.1	
		V _{CC} = 5.5V	3.85	
V _{IL}	Low-Level input Voltage	V _{CC} = 2V	0.5	V
		V _{CC} = 3V	0.9	
		V _{CC} = 5.5V	1.65	
V _I	Input Voltage	0	5.5	V
V _O	Output Voltage	0	5.5	V
I _{OL}	Low-Level Output Current	V _{CC} = 2V	50	μA
		V _{CC} = 5V ± 0.5V	4	mA
		V _{CC} = 3V	8	
Δt/ΔV	Input transition rise or fall rate	V _{CC} = 3.3V ± 0.3V	100	ns/V
		V _{CC} = 5V ± 0.5V	20	
T _A	Operating free-air temperature	-40	+125	°C

 Note: 5. Unused inputs should be held at V_{CC} or Ground.

Electrical Characteristics (@T_A = +25°C, unless otherwise specified.)

Symbol	Parameter	Test Conditions	V _{CC}	+25°C			-40°C to +85°C		-40°C to +125°C		Unit
				Min	Typ	Max	Min	Max	Min	Max	
V _{OL}	High-level Input Voltage	I _{OL} = 50μA	2V			0.1		0.1		0.1	V
			3V			0.1		0.1		0.1	
			4.5V			0.1		0.1		0.1	
		I _{OL} = 4mA	3V			0.36		0.44		0.55	
		I _{OL} = 8mA	4.5V			0.36		0.44		0.55	
I _I	Input Current	V _I = 5.5V or GND	0 to 5.5V			±0.1		±1		±2	μA
I _{oz}	Z-state Output Current	V _I = 5.5V or GND	0 to 5.5V			±0.25		±2.5		±10	μA
I _{CC}	Supply Current	V _I = 5.5V or GND I _O = 0	5.5V			1		10		40	μA
C _i	Input Capacitance	V _I = V _{CC} – or GND	5.5V		2.0	10		10		10	pF
θ _{JA}	Thermal Resistance Junction-to-Ambient	SOT25	(Note 6)		204						°C/W
		SOT353		371							
θ _{JC}	Thermal Resistance Junction-to-Case	SOT25	(Note 6)		52						°C/W
		SOT353		143							

Note: 6. Test conditions for SOT25, and SOT353: Device mounted on FR-4 substrate PC board, 2oz copper, with minimum recommended pad layout.

Switching Characteristics

 $V_{CC} = 3.3V \pm 0.3$ (see Figure 1)

Parameter	From (Input)	TO (OUTPUT)		+25°C			-40°C to +85°C		-40°C to +125°C		Unit
				Min	Typ	Max	Min	Max	Min	Max	
t_{pd}	A or B	Y	$C_L = 15pF$	0.6	4.6	7.5	0.6	8.5	0.6	9.0	ns
			$C_L = 50pF$	0.6	6.5	11.0	0.6	12.0	0.6	12.5	ns

 $V_{CC} = 5V \pm 0.5V$ (see Figure 1)

Parameter	From (Input)	TO (OUTPUT)		+25°C			-40°C to +85°C		-40°C to +125°C		Unit
				Min	Typ	Max	Min	Max	Min	Max	
t_{pd}	A or B	Y	$C_L = 15pF$	0.6	3.2	5.5	0.6	6.5	0.6	7.0	ns
			$C_L = 50pF$	0.6	4.6	7.5	0.6	8.0	0.6	8.5	ns

Operating Characteristics

 $T_A = +25^\circ C$

Parameter	Test Conditions	$V_{CC} = 5V$		Unit
		Typ		
C_{pd}	f = 1 MHz No Load	5		pF

Parameter Measurement Information

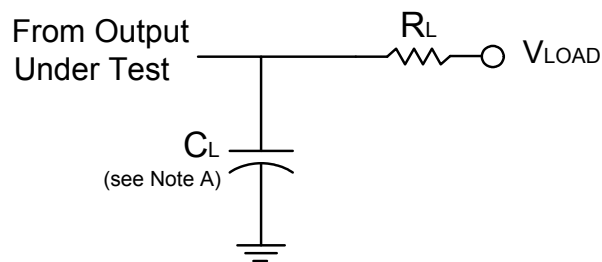

TEST	Condition
t_{PLZ} (see Notes D and E)	V_{LOAD}
t_{PZL} (see Notes D and F)	V_{LOAD}

V_{CC}	Inputs		V_M	V_{LOAD}	C_L	R_L	V_{Δ}
	V_I	t_r/t_f					
$3.3V \pm 0.3V$	V_{CC}	$\leq 3ns$	$V_{CC}/2$	V_{CC}	15pF	1K Ω	0.3V
$3.3V \pm 0.3V$	V_{CC}	$\leq 3ns$	$V_{CC}/2$	V_{CC}	50pF	1K Ω	0.3V
$5V \pm 0.5V$	V_{CC}	$\leq 3ns$	$V_{CC}/2$	V_{CC}	15pF	1K Ω	0.3V
$5V \pm 0.5V$	V_{CC}	$\leq 3ns$	$V_{CC}/2$	V_{CC}	50pF	1K Ω	0.3V

Parameter Measurement Information (cont.)

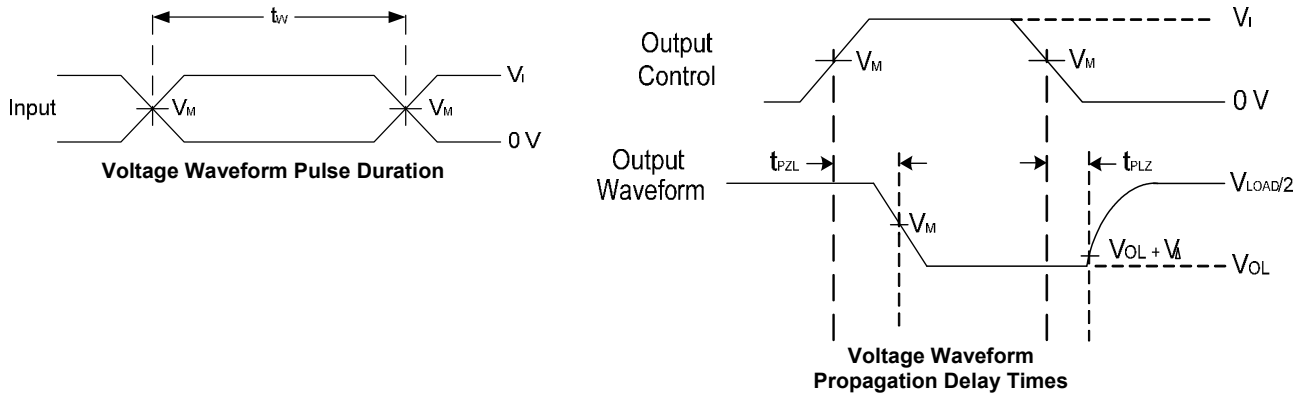
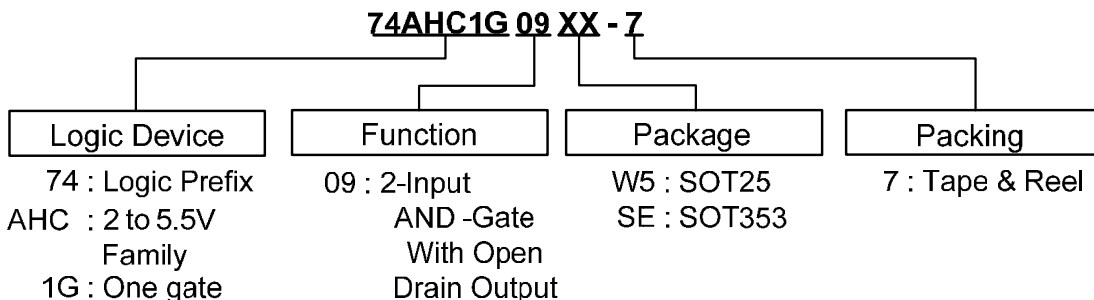

Figure 1 Load Circuit and Voltage Waveforms

- Notes:
- A. Includes test lead and test apparatus capacitance.
 - B. All pulses are supplied at pulse repetition rate ≤ 1 MHz.
 - C. The inputs are measured one at a time with one transition per measurement.
 - D. For the open drain device t_{PLZ} and t_{PZL} are the same as t_{PD} .
 - E. t_{PZL} is measured at V_M .
 - F. t_{PLZ} is measured at $V_{OL} + V_{\Delta}$.

Ordering Information



Part Number	Package Code	Packaging	7" Tape and Reel	
			Quantity	Part Number Suffix
74AHC1G09W5-7	W5	SOT25	3000/Tape & Reel	-7
74AHC1G09SE-7	SE	SOT353	3000/Tape & Reel	-7

Marking Information

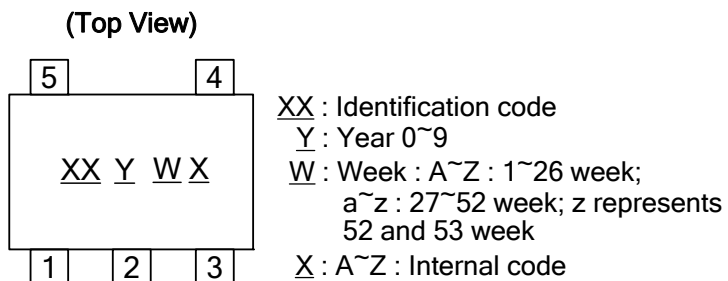

Part Number	Package	Identification Code
74AHC1G09W5	SOT25	YN
74AHC1G09SE	SOT353	YN

Package Outline Dimensions (All dimensions in mm.)

Please see AP02002 at <http://www.diodes.com/datasheets/ap02002.pdf> for latest version.

(1) Package Type: SOT25

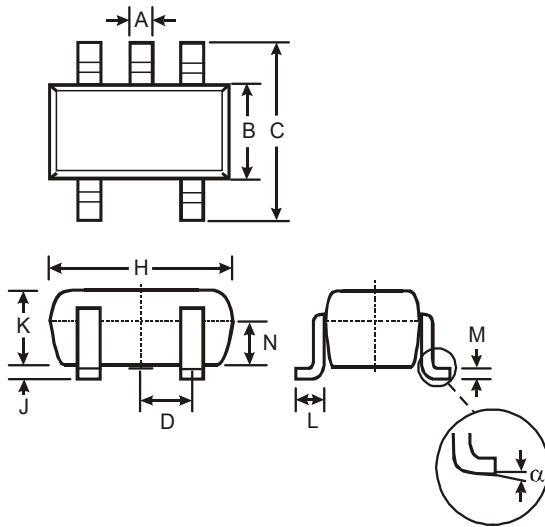

SOT25			
Dim	Min	Max	Typ
A	0.35	0.50	0.38
B	1.50	1.70	1.60
C	2.70	3.00	2.80
D	—	—	0.95
H	2.90	3.10	3.00
J	0.013	0.10	0.05
K	1.00	1.30	1.10
L	0.35	0.55	0.40
M	0.10	0.20	0.15
N	0.70	0.80	0.75
α	0°	8°	—
All Dimensions in mm			

(2) Package Type: SOT353

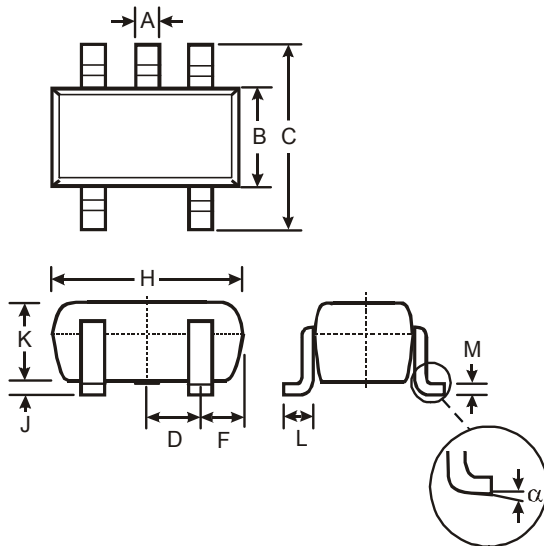

SOT353		
Dim	Min	Max
A	0.10	0.30
B	1.15	1.35
C	2.00	2.20
D	0.65 Typ	
F	0.40	0.45
H	1.80	2.20
J	0	0.10
K	0.90	1.00
L	0.25	0.40
M	0.10	0.22
α	0°	8°
All Dimensions in mm		

Suggested Pad Layout

Please see AP02001 at <http://www.diodes.com/datasheets/ap02001.pdf> for the latest version.

(1) Package Type: SOT25

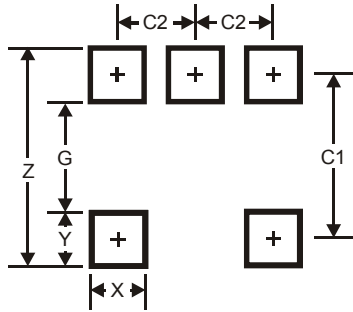

Dimensions	Value (in mm)
Z	3.20
G	1.60
X	0.55
Y	0.80
C1	2.40
C2	0.95

(2) Package Type: SOT353

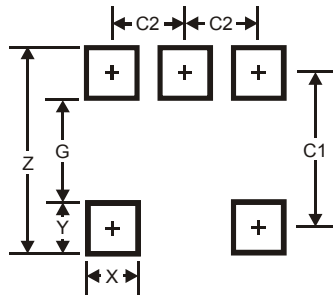

Dimensions	Value (in mm)
Z	2.5
G	1.3
X	0.42
Y	0.6
C1	1.9
C2	0.65

IMPORTANT NOTICE

DIODES INCORPORATED MAKES NO WARRANTY OF ANY KIND, EXPRESS OR IMPLIED, WITH REGARDS TO THIS DOCUMENT, INCLUDING, BUT NOT LIMITED TO, THE IMPLIED WARRANTIES OF MERCHANTABILITY AND FITNESS FOR A PARTICULAR PURPOSE (AND THEIR EQUIVALENTS UNDER THE LAWS OF ANY JURISDICTION).

Diodes Incorporated and its subsidiaries reserve the right to make modifications, enhancements, improvements, corrections or other changes without further notice to this document and any product described herein. Diodes Incorporated does not assume any liability arising out of the application or use of this document or any product described herein; neither does Diodes Incorporated convey any license under its patent or trademark rights, nor the rights of others. Any Customer or user of this document or products described herein in such applications shall assume all risks of such use and will agree to hold Diodes Incorporated and all the companies whose products are represented on Diodes Incorporated website, harmless against all damages.

Diodes Incorporated does not warrant or accept any liability whatsoever in respect of any products purchased through unauthorized sales channel. Should Customers purchase or use Diodes Incorporated products for any unintended or unauthorized application, Customers shall indemnify and hold Diodes Incorporated and its representatives harmless against all claims, damages, expenses, and attorney fees arising out of, directly or indirectly, any claim of personal injury or death associated with such unintended or unauthorized application.

Products described herein may be covered by one or more United States, international or foreign patents pending. Product names and markings noted herein may also be covered by one or more United States, international or foreign trademarks.

This document is written in English but may be translated into multiple languages for reference. Only the English version of this document is the final and determinative format released by Diodes Incorporated.

LIFE SUPPORT

Diodes Incorporated products are specifically not authorized for use as critical components in life support devices or systems without the express written approval of the Chief Executive Officer of Diodes Incorporated. As used herein:

A. Life support devices or systems are devices or systems which:

1. are intended to implant into the body, or
2. support or sustain life and whose failure to perform when properly used in accordance with instructions for use provided in the labeling can be reasonably expected to result in significant injury to the user.

B. A critical component is any component in a life support device or system whose failure to perform can be reasonably expected to cause the failure of the life support device or to affect its safety or effectiveness.

Customers represent that they have all necessary expertise in the safety and regulatory ramifications of their life support devices or systems, and acknowledge and agree that they are solely responsible for all legal, regulatory and safety-related requirements concerning their products and any use of Diodes Incorporated products in such safety-critical, life support devices or systems, notwithstanding any devices- or systems-related information or support that may be provided by Diodes Incorporated. Further, Customers must fully indemnify Diodes Incorporated and its representatives against any damages arising out of the use of Diodes Incorporated products in such safety-critical, life support devices or systems.

Copyright © 2013, Diodes Incorporated

www.diodes.com