

- 1
- 2
- 3
- 4
- 5
- 6
- 7
- 8
- 9
- 10
- 11
- 12
- 13
- 14
- 15
- 16
- 17
- 18

MATERIAL

Glass-fibre reinforced polyamide based (PA) technopolymer, RAL 9005 black colour or grey RAL 7040 (C33) colour, matte finish.

STANDARD EXECUTION

Pass-through holes for countersunk-head screws with cross mark ISO-7046-1-M6 (not included in the supply).

ROTATION PIN AND RETURN SPRINGS

AISI 303 stainless steel pin, AISI 302 stainless steel springs.

TECHNICAL DATA

The lifting resistance (F1) and tensile strength (F2) values reported in the table are the result of permanent deformation by means of the appropriate dynamometric equipment under the test conditions shown in the figure with ambient temperature.

ASSEMBLY INSTRUCTIONS

Drill holes with centre distance 80 +0.1/-0.1 in the sheet.



ELESA Original design

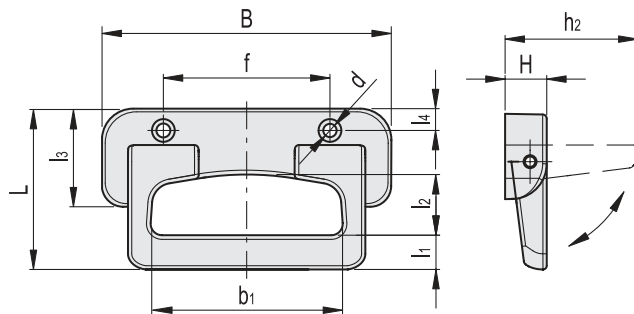
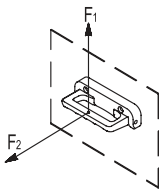

Conversion Table 1 mm = 0.039 inch	
B	
mm	inch
135	5.31

METRIC

Code	Description	B	f	L	H	h2	b1	l1	l2	l3	l4	d	F1 [N]	F2 [N]	⚖️
43801	MPE.135	135	80	74	20	63	90	16.5	29	41	8	6.3	1700	2500	127
43801-C33	MPE.135-C33	135	80	74	20	63	90	16.5	29	41	8	6.3	1700	2500	127