

REVISIONS				
P	LTR	DESCRIPTION	DATE	APVD
E		ECR-17-014151	25SEP2017	BM GS
F		ECR-21-123038	03DEC2021	LS MP
F1		ECR-22-129063	09FEB2022	LS MP
G		ECR-22-131298	03MAR2022	LS MP

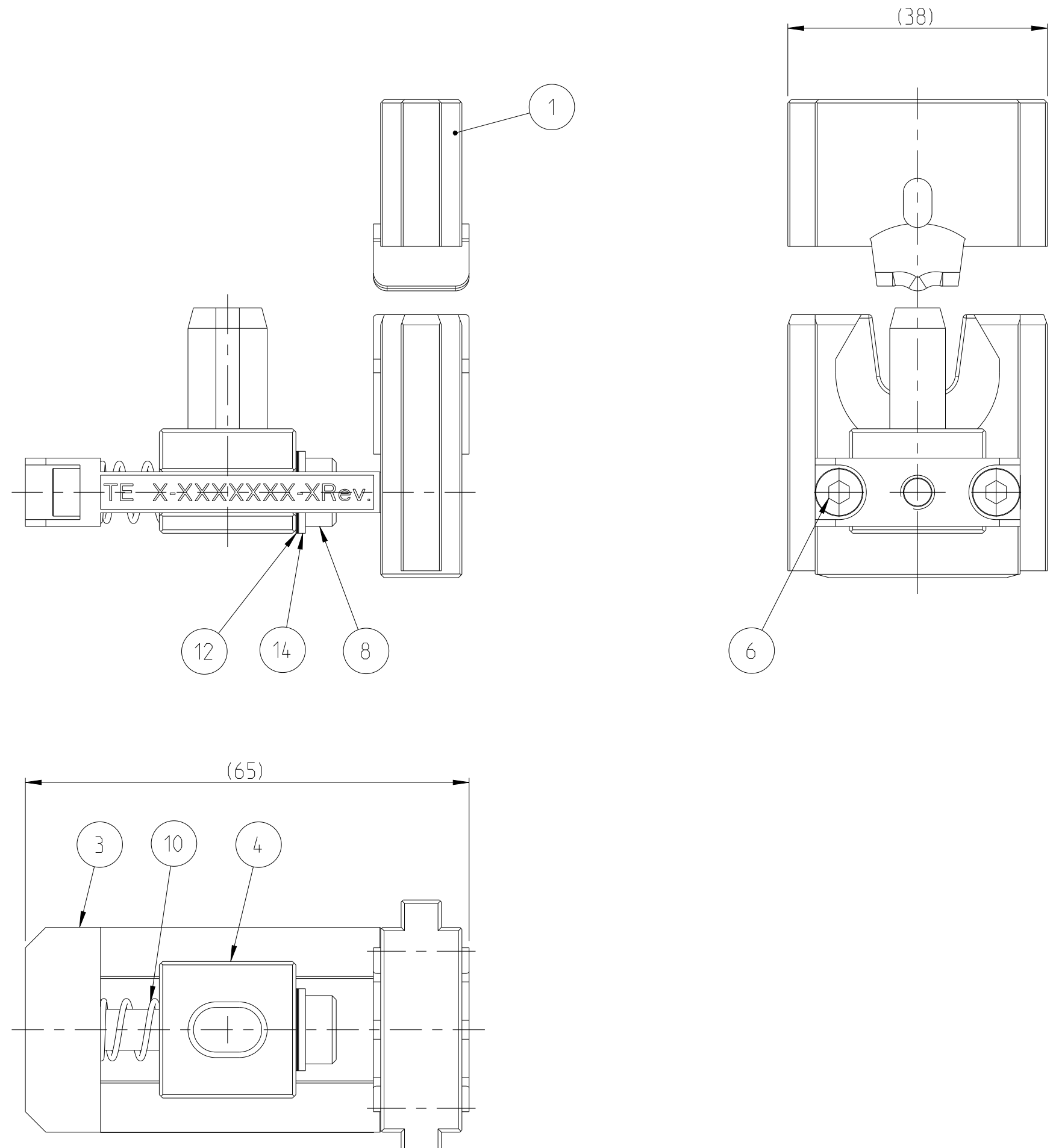

TERMINAL NAME	RING TONGUE, CONTACT
TE TERMINAL PART NUMBER(S)	2-2177380-1 / 2-2177380-2 (INTERCABLE)
APPLICATION SPECIFICATION	114-94133 / VW TAB 016.358.AC
REFERENCE DRAWING	-
USED ON	528008-4 (HV CRIMPING MACHINE) - OBSOLETE WITH 541868-2 (ADAPTER)
INSTRUCTION SHEET	-

CABLE SUPPLIER/SPECIFICATION	CABLE SIZE	CRIMP HEIGHT	CRIMP HEIGHT REFERENCE SETTING
COROPLAST - FHLR2GCB2G/A14	35mm2	5.85 ±0.1	-

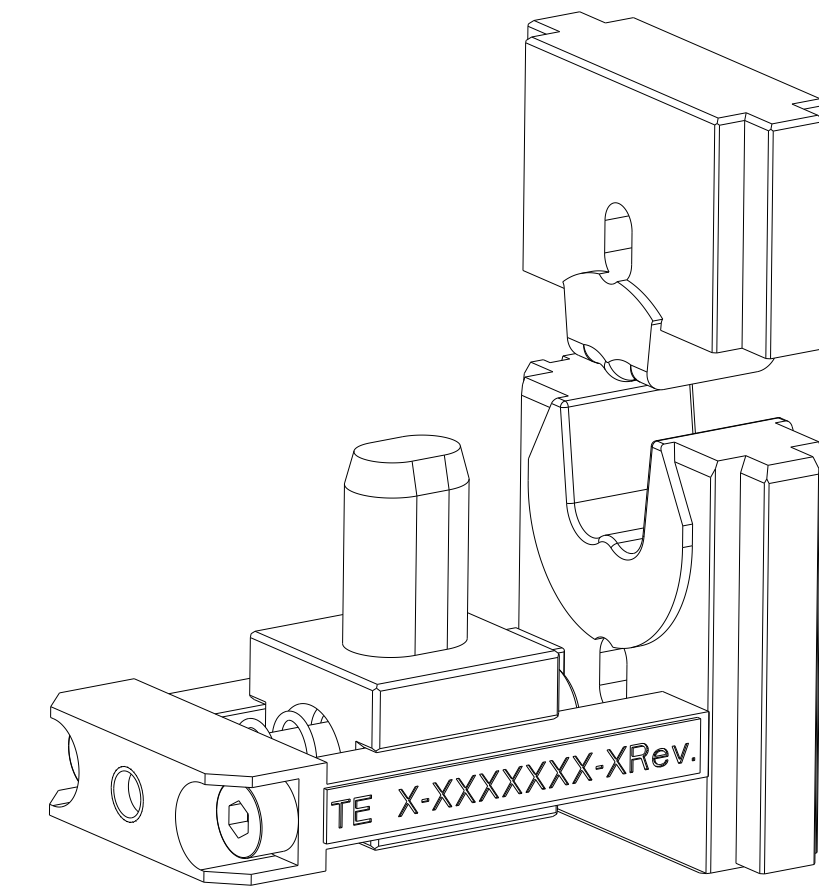

1	519115-4	A	WASHER, SHIM RING, 1.0 THICK	14
4	519035-4	O	WASHER, SHIM RING, 0.1 THICK	12
1	2-22282-0	D	SPRING, COMPRESSION	10
1	519152-6	A	FITTING SCREW	8
2	1-519072-4	O	SCREW, CAP, SOCKET HD, METRIC	6
1	6-519709-3	E	LOCATOR IPT-VW	4
1	519579-7	C	BAY IPT-VW	3
1	8-1579019-8	B	DIE SET IPT-VW WIRE, 35SQ.MM	1
QTY	PART NO	REV	DESCRIPTION	ITEM NO

ALTERNATIVE COMPONENTS FOR USING HV20, TCPN 2348822:
 1x 2326383-1 (BASE PLATE ASSEMBLY)
 1x 2234755-1 (ADAPTOR ASSY, FOR 528041, HV-20T)
 1x 541868-1 (HV- CM DIE-SET ADAPTER)

THIS DRAWING IS A CONTROLLED DOCUMENT.		DWN R. Germann 06 JUN 2012	TE Connectivity	
		CHK G. Stegmayer 06 JUN 2012		
DIMENSIONS: mm		APVD G. Stegmayer 06 JUN 2012	NAME DIE SET IPT T 35MM2	
TOLERANCES UNLESS OTHERWISE SPECIFIED:		PRODUCT SPEC	-	
0 PLC ±		APPLICATION SPEC	-	
1 PLC ±		WEIGHT	-	
2 PLC ±		CUSTOMER DRAWING	SCALE 3:2 SHEET 1 OF 1 REV G	
3 PLC ±				
4 PLC ±				
ANGLES ±				
FINISH				
-				
-				