



Series 222A

6.2 x 6.2mm Compact Tactile Switch

- Standard through hole and surface mount gull-wing terminal configurations
- Compatible with IR reflow, wave, and manual soldering
- Compatible with automatic dip-soldering
- Variety of operating force and actuator height options



Description

Excellent tactile feedback provides the user with simple and intuitive operation. The robust internal structure ensures long product life to meet various application requirements. Common product dimensions provide options to match your existing applications.

Ordering Information

Series	Terminal Type	Actuating Direction	Actuator Height "L"	Actuator Force	Packaging Type																												
222A	M	V	A	A	R																												
<table border="1"> <thead> <tr> <th>Code</th> <th>Spec.</th> </tr> </thead> <tbody> <tr> <td>M</td> <td>Surface mount gull wing</td> </tr> <tr> <td>U</td> <td>Surface mount U terminal</td> </tr> <tr> <td>D</td> <td>Through hole</td> </tr> </tbody> </table>		Code	Spec.	M	Surface mount gull wing	U	Surface mount U terminal	D	Through hole	<table border="1"> <thead> <tr> <th>Code</th> <th>Spec.</th> </tr> </thead> <tbody> <tr> <td>V</td> <td>Vertical</td> </tr> <tr> <td>S1</td> <td>Side</td> </tr> </tbody> </table>		Code	Spec.	V	Vertical	S1	Side	<table border="1"> <thead> <tr> <th>Code</th> <th>Spec.</th> </tr> </thead> <tbody> <tr> <td>A</td> <td>160 gf, black</td> </tr> <tr> <td>B</td> <td>260 gf, white</td> </tr> <tr> <td>C</td> <td>100 gf, blue</td> </tr> </tbody> </table> <p>SIDE ACTUATION (S1) ONLY AVAILABLE WITH 160 gf</p> <table border="1"> <thead> <tr> <th>Code</th> <th>Spec.</th> </tr> </thead> <tbody> <tr> <td>BLANK</td> <td>Bag packaging (Through hole only)</td> </tr> <tr> <td>R</td> <td>Tape & reel packaging (Surface mount only)</td> </tr> </tbody> </table>		Code	Spec.	A	160 gf, black	B	260 gf, white	C	100 gf, blue	Code	Spec.	BLANK	Bag packaging (Through hole only)	R	Tape & reel packaging (Surface mount only)
Code	Spec.																																
M	Surface mount gull wing																																
U	Surface mount U terminal																																
D	Through hole																																
Code	Spec.																																
V	Vertical																																
S1	Side																																
Code	Spec.																																
A	160 gf, black																																
B	260 gf, white																																
C	100 gf, blue																																
Code	Spec.																																
BLANK	Bag packaging (Through hole only)																																
R	Tape & reel packaging (Surface mount only)																																
Combination		Spec.																															
Code	A	B	C	D	E	F	G	H	I	J																							
Actuator Height	4.3	5.0	7.0	9.5	3.85	8.35	6.85	5.85	8.0	3.6																							
222AMV	☆	☆	☆	☆					☆																								
222ADV	☆	☆	☆	☆					☆																								
222AMS1	☆									☆																							
222ADS1					☆	☆	☆	☆																									
222AUV			☆	☆					☆																								

Notes: Contact CTS for other common features not listed.

Electrical Specifications

Parameter	Conditions & Remarks	Min	Max	Unit
Contact Resistance			100	milliohms
Insulation Resistance	Between insulated terminals	100		Megohms
Dielectric Strength	1 minute between adjacent switches		250	VAC
Nonswitching Rating			50 or 12	mA or VDC

Mechanical and Environmental

Soldering	Maximum reflow temperature, 260°C for 5 seconds Maximum manual temperature, 350°C for 3 seconds			
Actuation Life	100 gf 160 gf 260 gf	1,000,000 1,000,000 200,000		cycles
RoHS	Lead-Free. Fully compliant to RoHS Directive 2011/65/EU and 2015/863			
Operating Force	100±50 gf 160±50 gf 260±50 gf			
Actuator Strength	3 Kgf maximum			
Travel	0.25±0.15mm (vertical actuation) 0.25 ^{+0.2} _{-0.1} mm (side actuation)			
Operating Temperature Range	-40°C to +85°C			
Storage Temperature Range	-40°C to +90°C			
Packaging	Standard bag packaging for through hole terminal Standard tape and reel packaging for gull wing terminal			

Soldering Profile

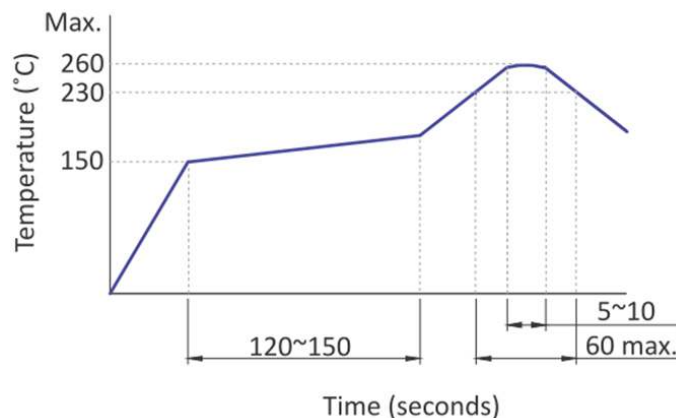

Mechanical Specifications

Figure 1 – Surface Mount Gull Wing, 222AM, Vertical Actuation

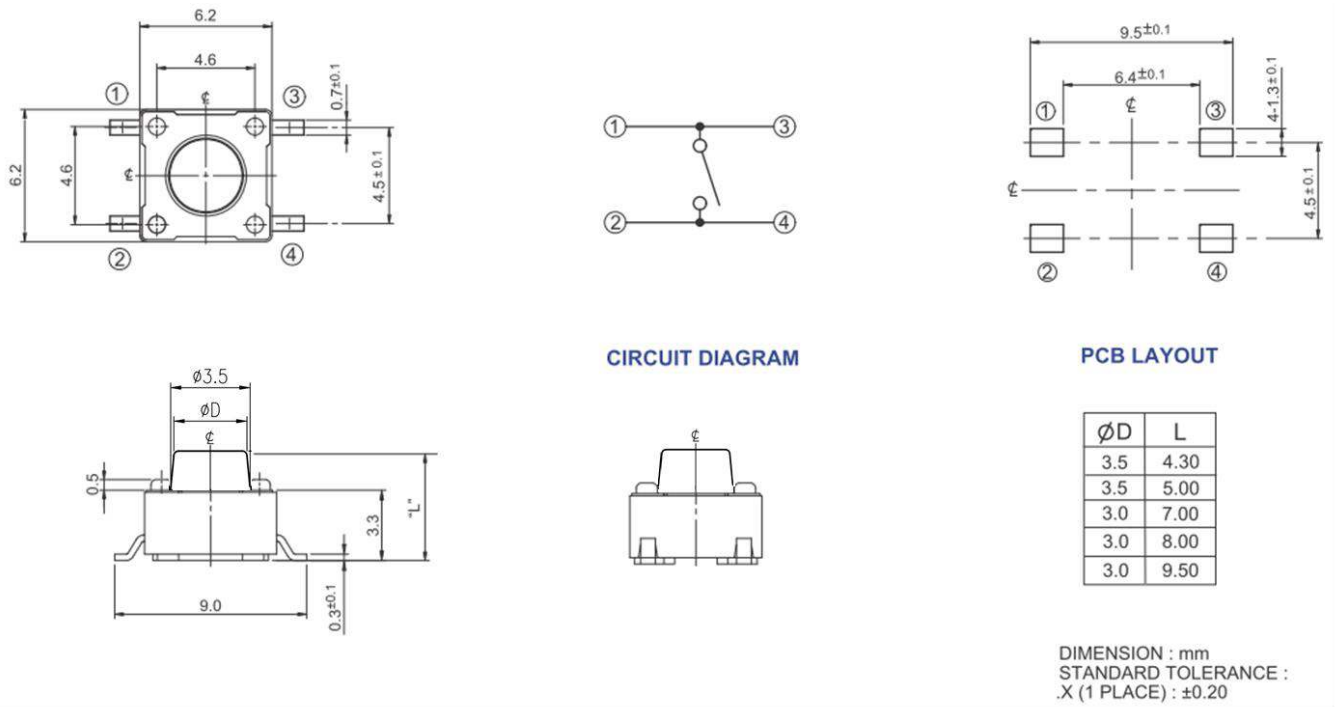

Figure 2 – Through-Hole, 222AD, Vertical Actuation

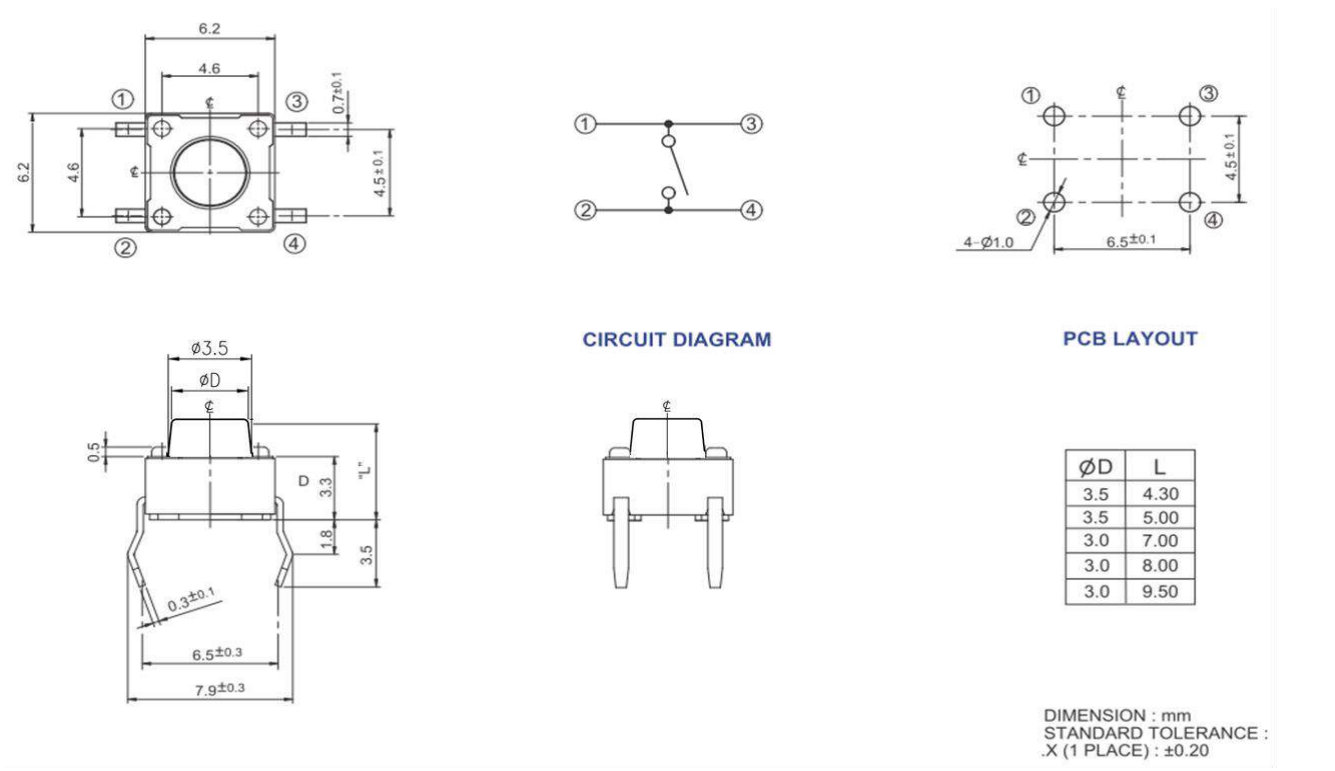

Figure 3 – Through-Hole, 222ADS1, Side Actuation

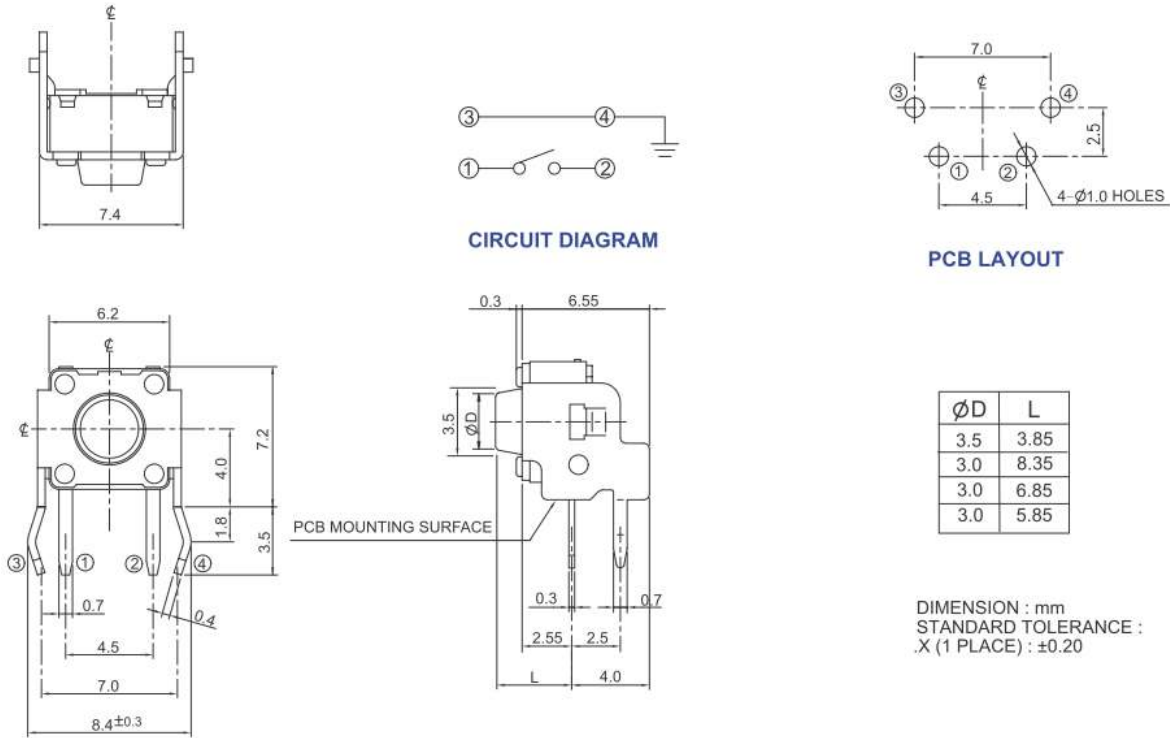

Figure 4 –Surface Mount Gull Wing, 222AMS1, Side Actuation

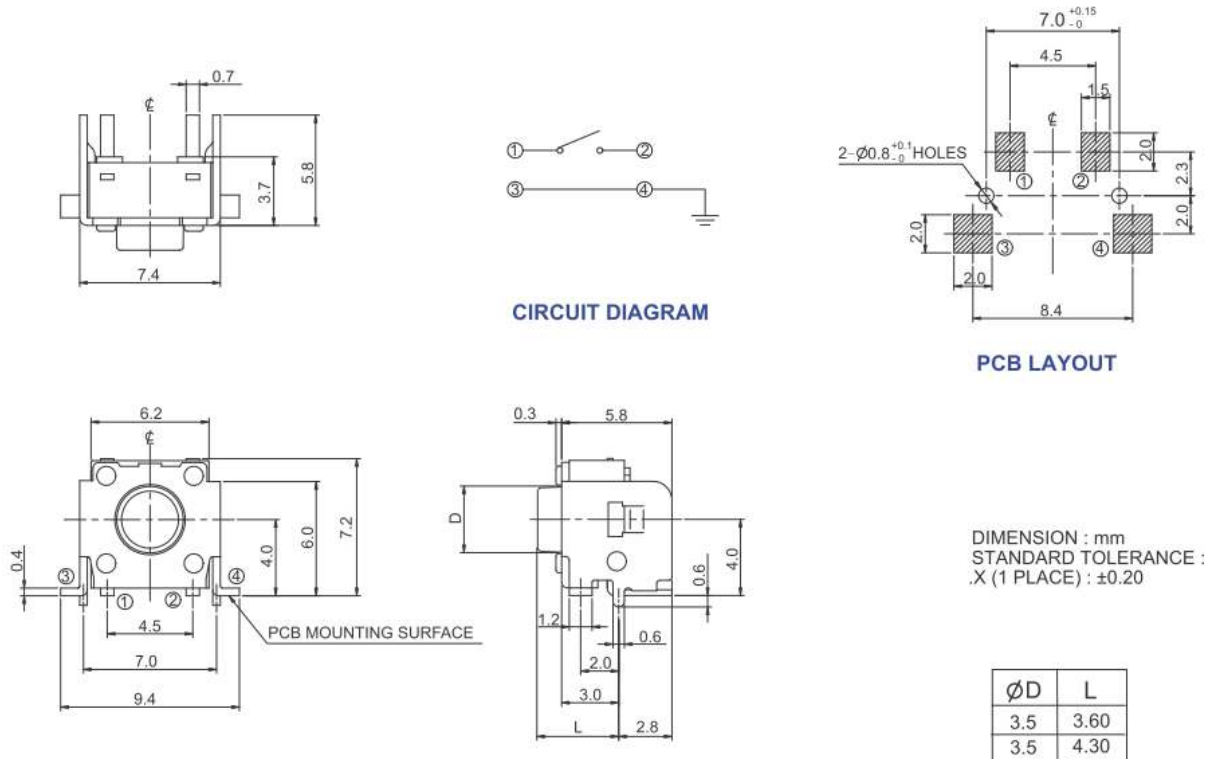
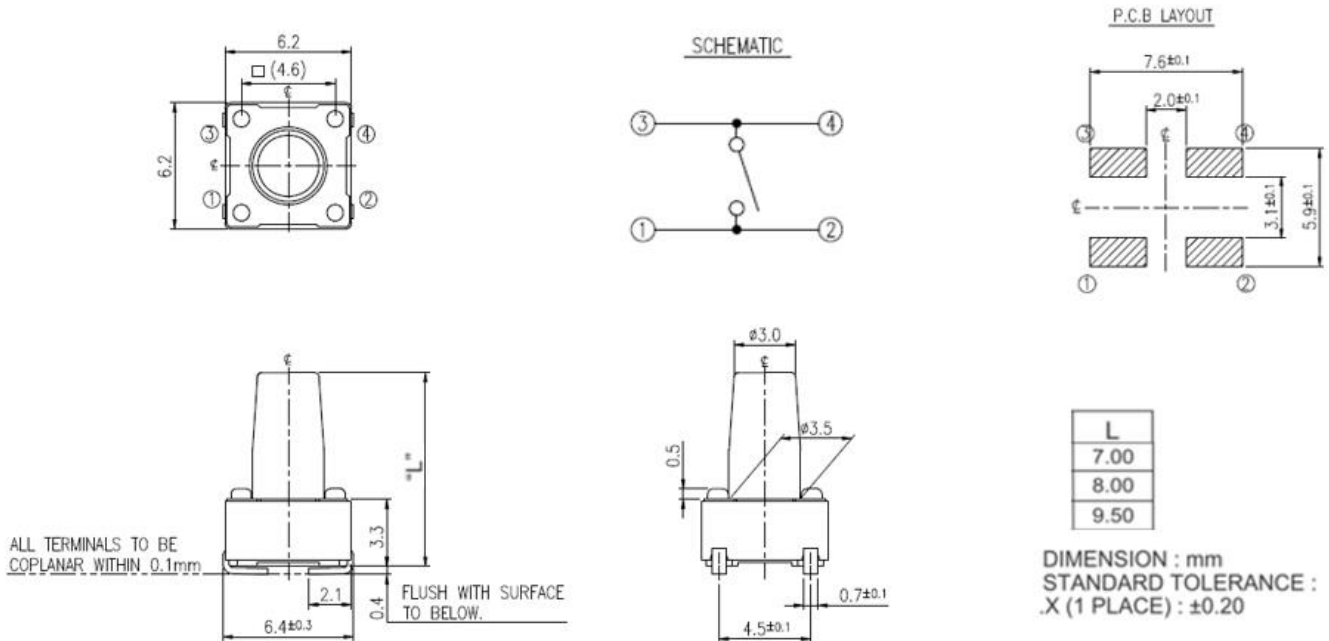

Figure 5 – Surface Mount U terminal type, 222AU, Vertical Actuation



Packing: Tape and Reel

Surface Mount Gull Wing, Top Actuation, 222AMV...

The Packing Specifications:

Structure and materials:

No	PART NAME	MATERIAL
①	REEL	POLYSTYRENE
②	CARRIER TAPE	POLYSTYRENE
③	COVER TAPE	POLYESTER

1. More than 10 empty pockets should remain at each end of the carrier tape for each reel.
2. Shortage of less than 10 pcs a reel is acceptable but no more than 3 consecutive empty pockets are allowed.
3. Stripping strength of cover tape is between 10 gf to 70 gf and stripping angle should be within 165°~180°.
4. The product in the pocket of carrier tape should be placed in a specified correct position.
5. Tape and reel per EIA-481.
6. Dimensions:

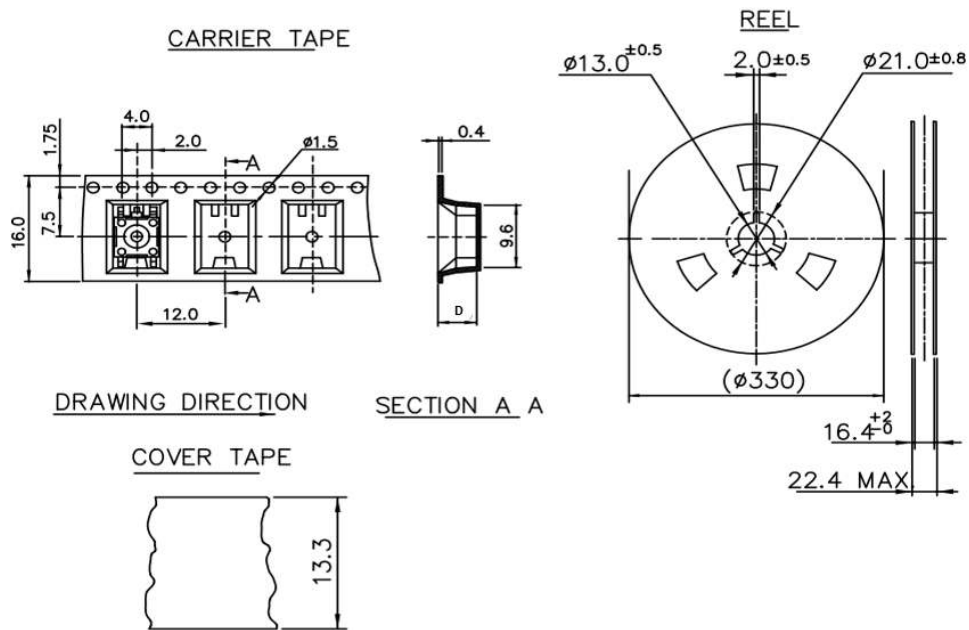

Switch Type	Packing Quantity/Reel	Dimension "D"
222AMVA	1000	5.3
222AMVB	1000	5.3
222AMVC	550	7.2
222AMVD	400	9.5
222AMVI	400	8.0

Surface Mount Gull Wing, Side Actuation, 222AMS1...

The Packing Specifications:

Structure and materials:

No	PART NAME	MATERIAL
①	REEL	POLYSTYRENE
②	CARRIER TAPE	POLYSTYRENE
③	COVER TAPE	POLYESTER

1. Packing quantity: 500 pcs/reel
2. More than 10 empty pockets should remain at each end of the carrier tape for each reel.
3. Shortage of less than 10 pcs a reel is acceptable but no more than 3 consecutive empty pockets are allowed.

4. Stripping strength of cover tape is between 10 gf to 70 gf and stripping angle should be within 165°~180°.
5. The product in the pocket of the carrier tape should be placed in a specified correct position.
6. Tape and reel per EIA-481.
7. Dimensions:

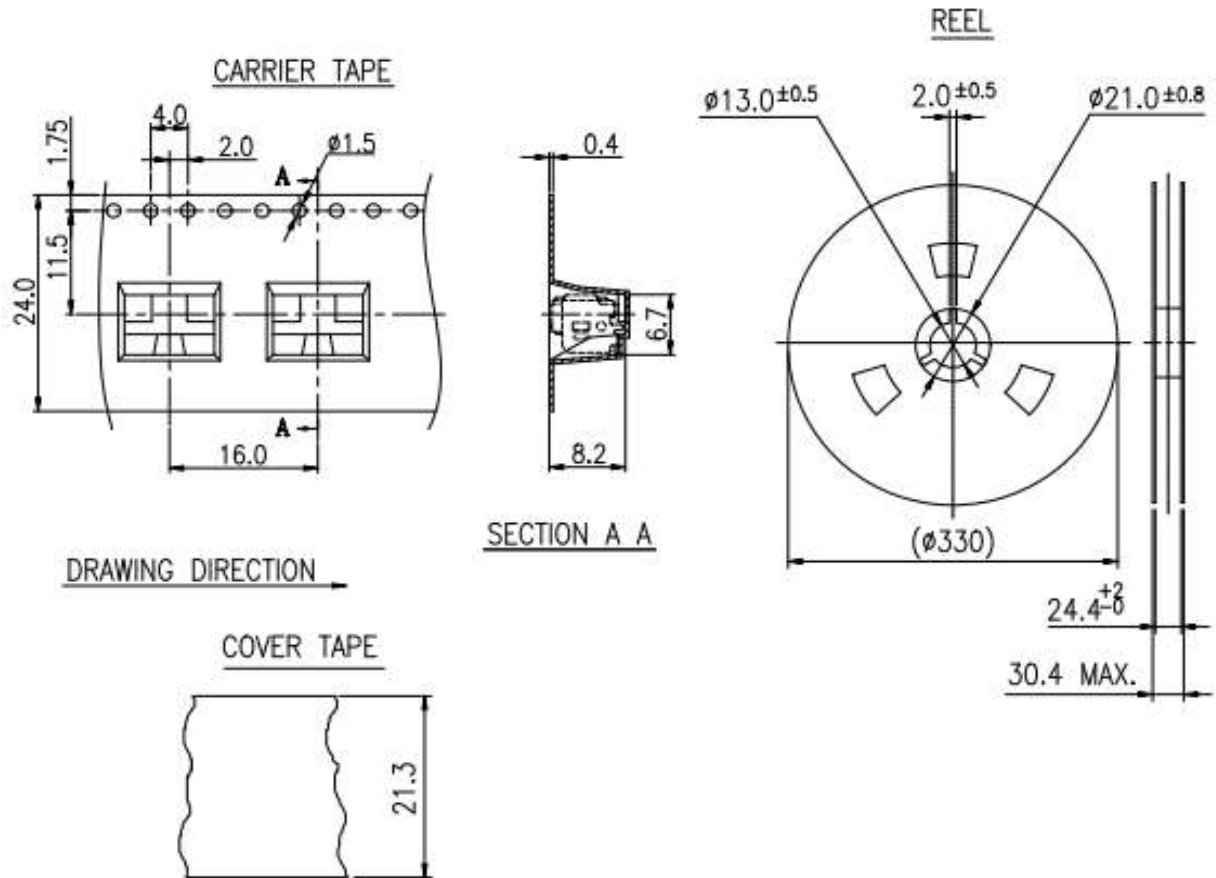

Surface Mount U terminal type, Vertical Actuation, 222AUV...

The Packing Specifications:

Structure and materials:

No	PART NAME	MATERIAL
①	REEL	POLYSTYRENE
②	CARRIER TAPE	POLYSTYRENE
③	COVER TAPE	POLYESTER

1. Packing quantity: 400 pcs/reel
2. More than 10 empty pockets should remain at each end of the carrier tape for each reel.
3. Shortage of less than 10 pcs a reel is acceptable but no more than 3 consecutive empty pockets are allowed.

Series 222A

Tactile Switch

4. Stripping strength of cover tape is between 10 gf to 70 gf and stripping angle should be within 165°~180°.
5. The product in the pocket of the carrier tape should be placed in a specified correct position.
6. Tape and reel per EIA-481.
7. Dimensions:

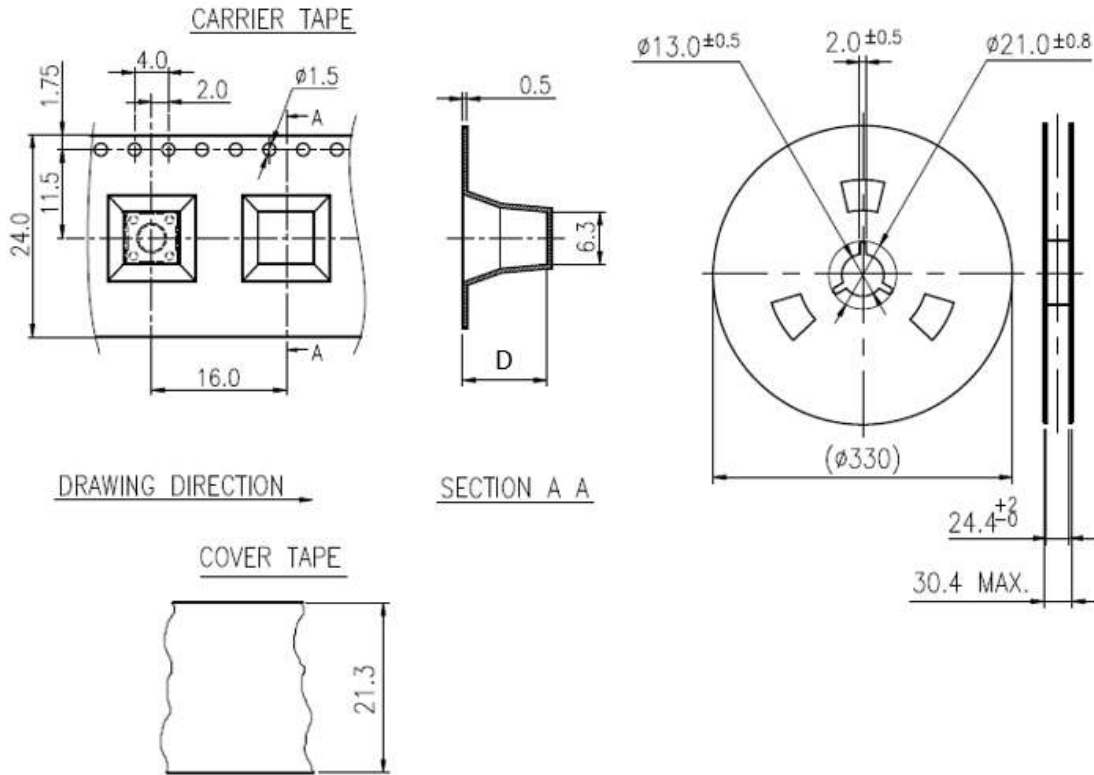

Switch Type	Dimension "D"
222AUVC	7.4
222AUVI	8.4
222AUVD	10.0