

THIS DRAWING IS UNPUBLISHED.
 RELEASED FOR PUBLICATION
 © COPYRIGHT - TE Connectivity ALL RIGHTS RESERVED

REVISIONS					
P.	LN.	DESCRIPTION	DATE	BY	APP.
A12		REVISED PER ECR-17-013047	12SEP2017	J.Z.	D.Z.

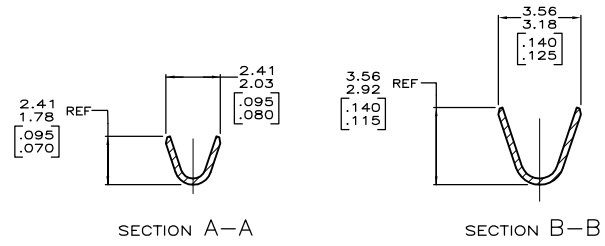
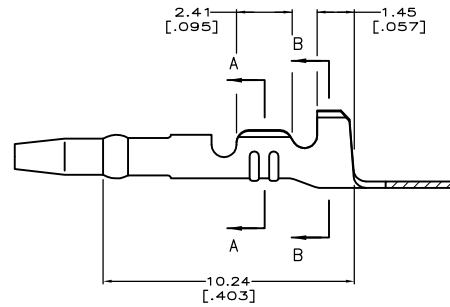
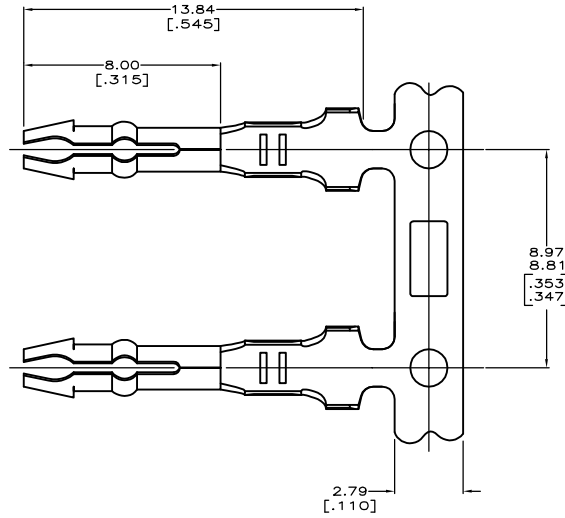
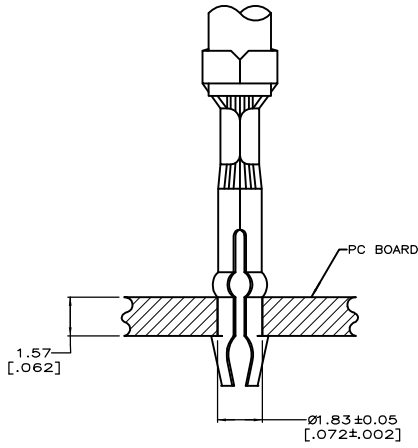

- △ NOTE DELETED.
- PARTS COMPLY WITH AMP SOLDERABILITY SPEC 109-11-3.
 - WIRE RANGE: 0.3 - 0.6 mm² (22 - 20 AWG).
 - INSULATION RANGE: 2.54 [.100] DIA MAX.
 - DIMENSIONS IN BRACKETS ARE IN INCHES.

MINI	PRE TIN	0.25 [0.010] BRASS	3-42642-3
MINI	PRE TIN-LEAD	0.25 [0.010] BRASS	42642-3
APPLICATOR TYPE	FINISH	MATERIAL	PART NUMBER

METRIC

THIS DRAWING IS A CONTROLLED DOCUMENT. BY: X. WHITAKER 11/04/2008
 OR OTHERWISE SPECIFIED: X. WHITAKER 11/04/2008
 X. WHITAKER 11/04/2008

TE Connectivity

TERMINAL, AMP-IN(TM)

APPLICATOR TYPE: MINI
 FINISH: PRE TIN-LEAD
 MATERIAL: 0.25 [0.010] BRASS
 PART NUMBER: 3-42642-3

DATE: 12SEP2017
 DRAWING NO: 00779
 CUSTOMER DRAWING

SCALE: 10:1
 SHEET: 1 of 1
 REV: A12