

- △ HOUSING-MATERIAL : LIQUID-CRYSTAL-POLYMER.
- △ CONTACT-MATERIAL : PHOS. BRONZE.
- △ LATCH-MATERIAL : BRASS, NICKEL PLATE.
- △ CONTACT-PLATE: 0.00508[.000200] MIN MATTE TIN OVER 0.00127 [.000050] MIN NICKEL.
- 5. IN ADDITION TO THOSE RECOMMENDED "SIMM" P.C. BOARD DIMENSIONS AND TOLERANCES SHOWN, ALL JEDEC SPECIFICATIONS APPLY AS SHOWN ON MO-116, ISSUE A.
- 6. RECOMMENDED MATING S.I.M.M. TAB METALLURGY: BASE METAL-COPPER. PLATING TO BE 0.00762[.000300] MIN TIN/LEAD OVER 0.00127[.000050] MIN NICKEL.
- △ DATE CODE: (YEAR WEEK) XXXX FORMAT, LOCATED APPROXIMATELY AS SHOWN ON OPPOSITE SIDE.

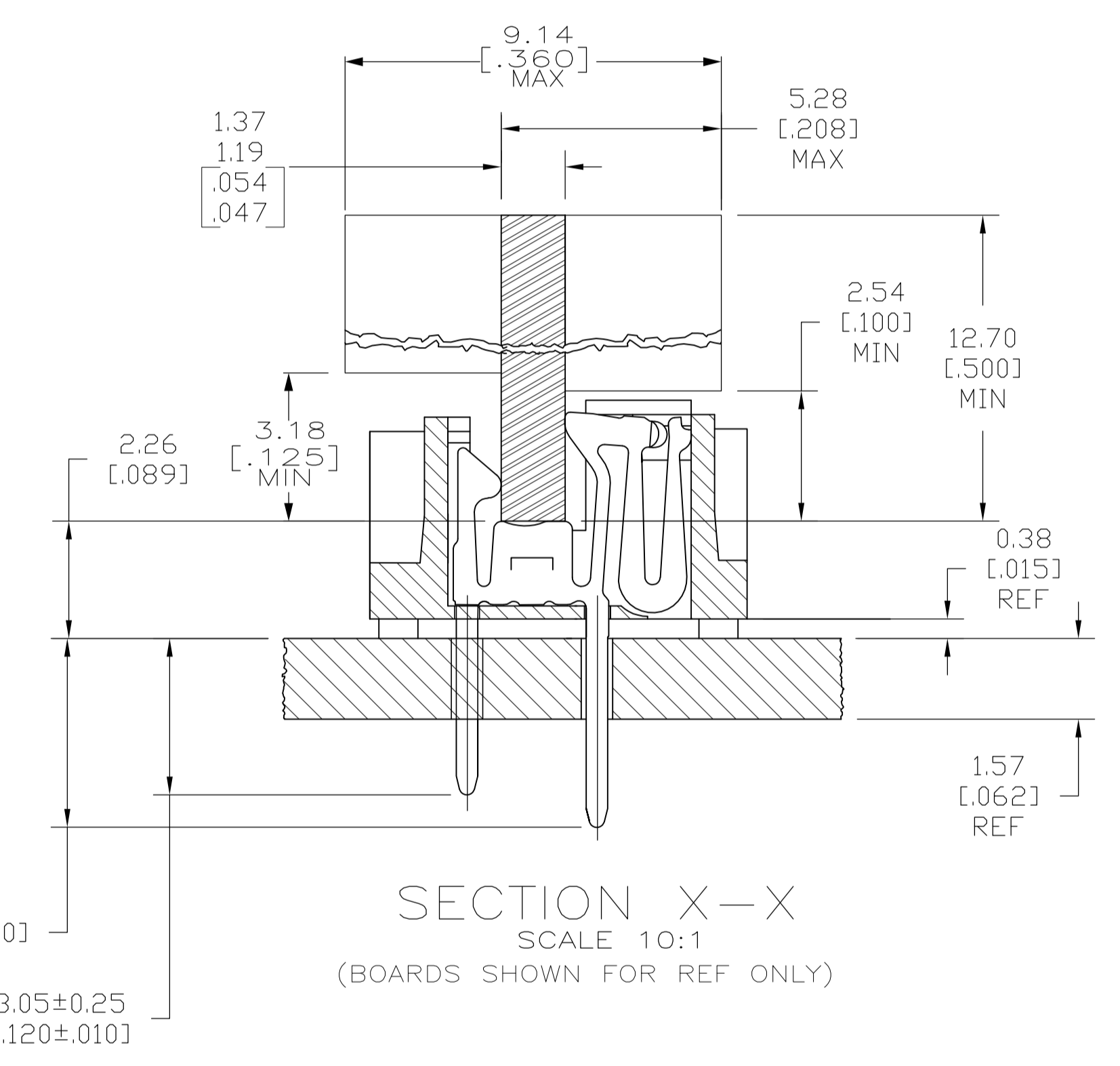

WITH CENTER POST	3.68[.145]	118.11[4.650]	111.35[4.384]	60.96[2.400]	49.53[1.950]	125.73[4.950]	105.41[4.150]	80	5822030-4
	3.68[.145]	107.95[4.250]	101.19[3.984]	55.88[2.200]	44.45[1.750]	115.57[4.550]	95.25[3.750]	72	5822030-3
	G	F	E	D	C	B	A	NO. OF POSN	PART NO

THIS DRAWING IS A CONTROLLED DOCUMENT.		DIN S. WAITMAN SJANOS		TE Connectivity	
DIMENSIONS: mm [INCHES]		TOLERANCES UNLESS OTHERWISE SPECIFIED:		NAME	
<ul style="list-style-type: none"> 0 PLC ± - 1 PLC ± - 2 PLC ± - 3 PLC ± 0.1[.005] 4 PLC ± - ANGLES ± - 		<ul style="list-style-type: none"> 0 PLC ± - 1 PLC ± - 2 PLC ± - 3 PLC ± 0.1[.005] 4 PLC ± - ANGLES ± - 		PRODUCT SPEC	
MATERIAL		FINISH		APPLICATION SPEC	
CUSTOMER DRAWING		SCALE 4:1		SHEET 1 OF 1	