

10119187 - X0J - XXXLF

LEAD-FREE DESIGNATION ONLY WITH APPLICABLE PLATING CODES

4-COLUMN DIFFERENTIAL SIGNAL

LETTER	PERFORMANCE-BASED PLATING (SEE NOTE 2)	
	TARGET APPLICATION	LEAD-FREE (LF)
B	TELCORDIA CO	NO
C	TELCORDIA UE	NO
D	TELCORDIA CO	YES
E	TELCORDIA UE	YES

NUMBER	GUIDE PIN STYLE, HEIGHT
0	STANDARD GUIDE PIN MACHINED, 31.6mm
4	STANDARD GUIDE PIN MACHINED, 25.7mm

NUMBER	CONTACT MATING WIPE LENGTH		COMPLIANT PIN DRILL SIZE
	SIGNAL	GROUND	
1	2	4	Ø0.55 [0.0217"]
2	3	4	Ø0.55 [0.0217"]
3	2	4	Ø0.45 [0.0177"]
4	3	4	Ø0.45 [0.0177"]
5	2	3	Ø0.55 [0.0217"]
6	3	3	Ø0.55 [0.0217"]
7	2	3	Ø0.45 [0.0177"]
8	3	3	Ø0.45 [0.0177"]

MODULE DESCRIPTION	LETTER DESIGNATION REPRESENTED IN DASH NUMBER										BASE MODULE
LEFT POLARIZING GUIDANCE MODULE (SEE SHEET 3)	J	A	B	C	D	E	F	G	H		
RIGHT POLARIZING GUIDANCE MODULE (SEE SHEET 4)	Y	P	Q	R	S	T	U	V	W		
OPEN MODULE (TWO WALL) (SEE SHEET 2)	0 (ZERO)										
LEFT WALL MODULE (SEE SHEET 5)	L										
RIGHT WALL MODULE (SEE SHEET 6)	M										
FOUR WALL MODULE (SEE SHEET 7)	I (ONE)										

TABLE 1: OPTIONAL PCB HOLE SIZE (SEE NOTE 11)

	GROUNDED	UNGROUNDED
FINISHED	Ø2.35-2.55	Ø2.35-2.55
PAD	Ø5.50	N/A
PLATED	YES	NO
DRILL (mm/in)	2.58/.1015	2.44/.096

TABLE 2: OPTIONAL SCREW TYPE (SEE NOTE 10)

SCREW P/N	DESCRIPTION	BOARD THICKNESS
10091790-002LF	#2.56 X .375" PHILIPS PANHEAD W/SQ CONICAL WASHER	1.60 - 5.00
10091790-003LF	#2.56 X .500" PHILIPS PANHEAD W/SQ CONICAL WASHER	5.00 - 10.00

spec ref	-	dr	Roger Ng	2011/1/22	projection	MM	size	A2	scale	4:1
tolerance std	ASME Y14.5	eng	Sandar Soe	2014/10/02	chr	-	ecn no	ELX-S-18843-1		
	TOLERANCES UNLESS OTHERWISE SPECIFIED	appr	Chen-Hong Tan	2014/12/10	product family	XCEDE	rel level	Released		
surface	linear	0.X	±0.2							
		0.XX	±0.10							
		0.XXX	±0.050							
	angular	0°	±2°							
www.fci.com		cat. no.		Product - Customer Drw		sheet 1 of 8		rev		B

OPEN (2- WALL) MODULE

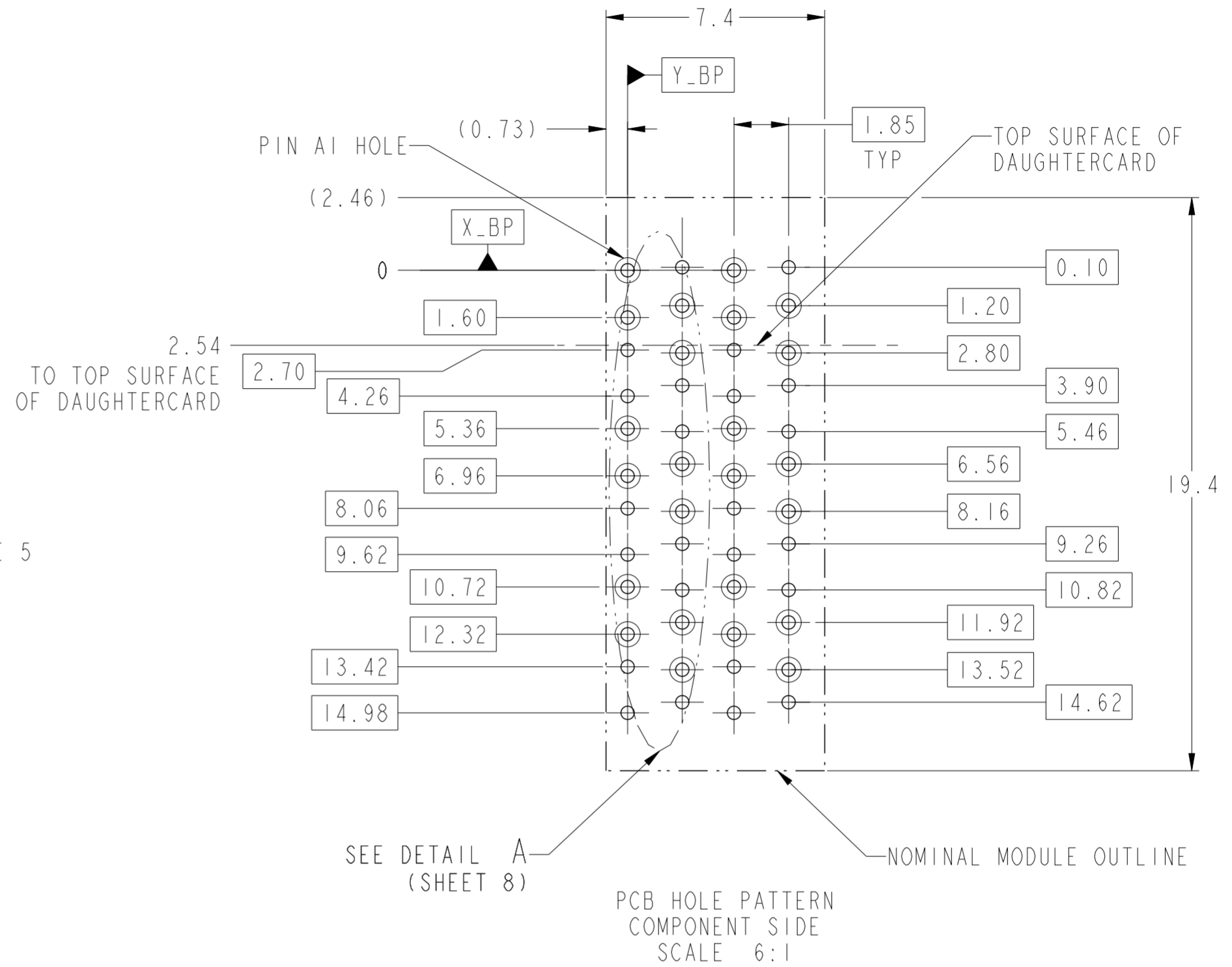
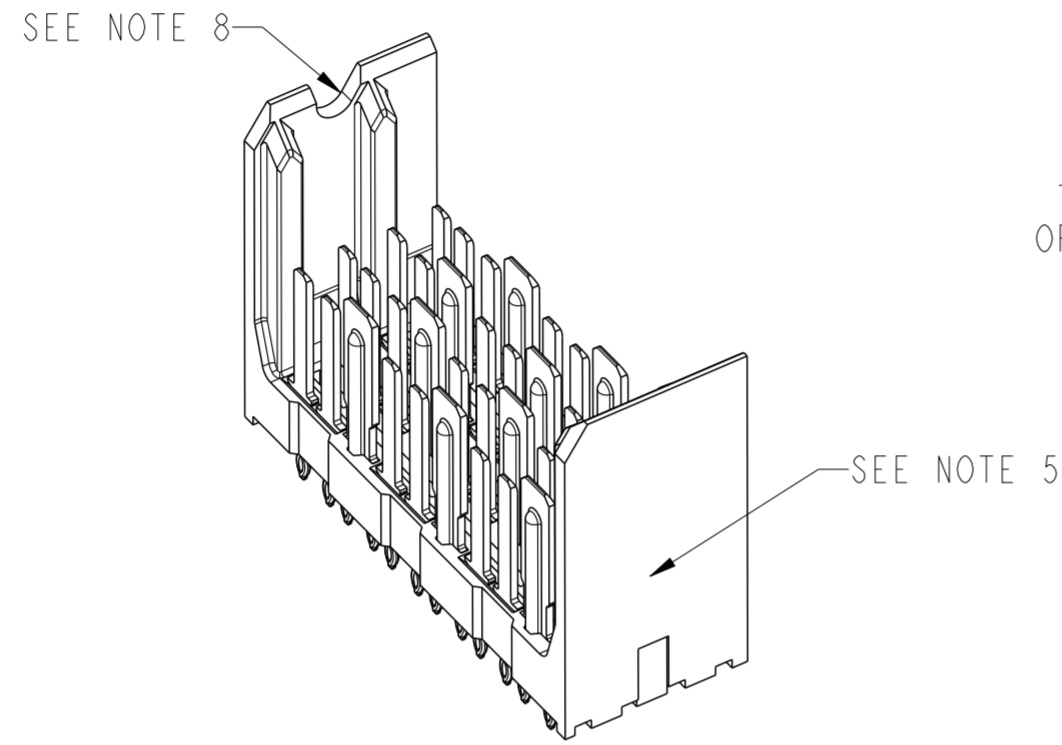
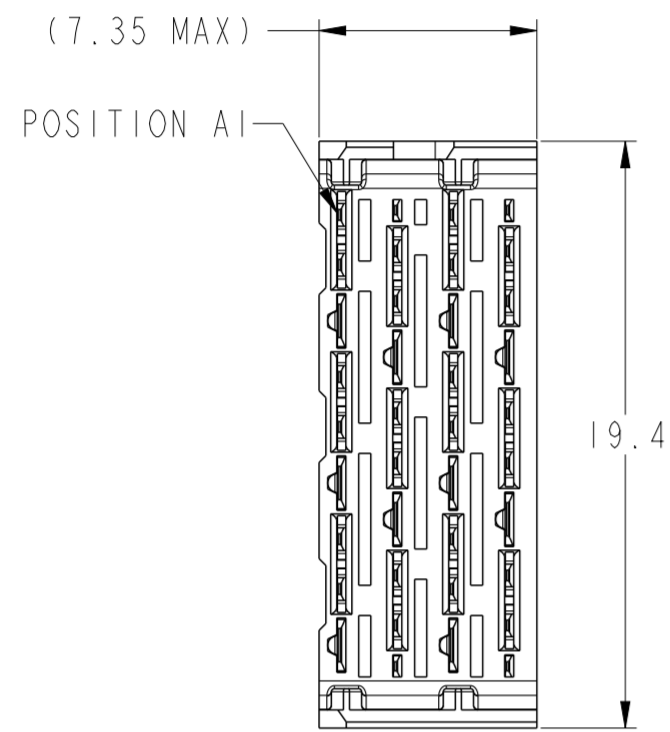

6.2 (4MM WIPE WIDE GROUNDS)  
5.2 (3MM WIPE WIDE GROUNDS)

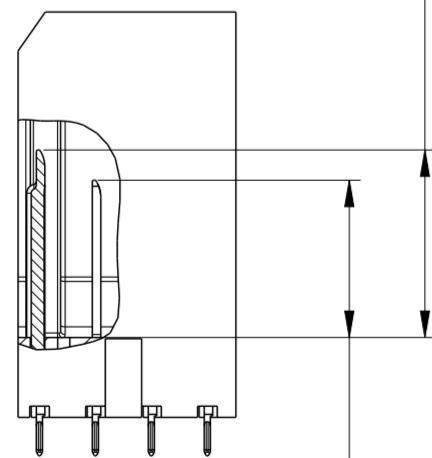

5.2 (3MM SMALL END GROUNDS)  
5.2 (3MM WIPE SIGNALS)  
4.2 (2MM WIPE SIGNALS)  
SEE P/N TREE

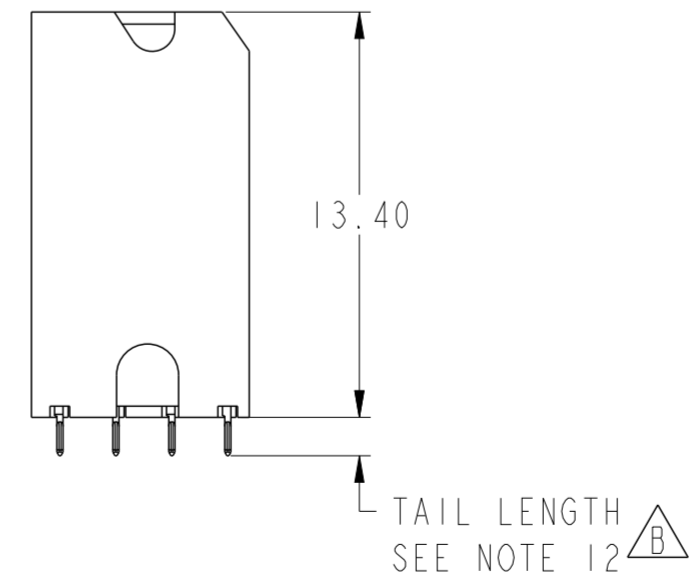
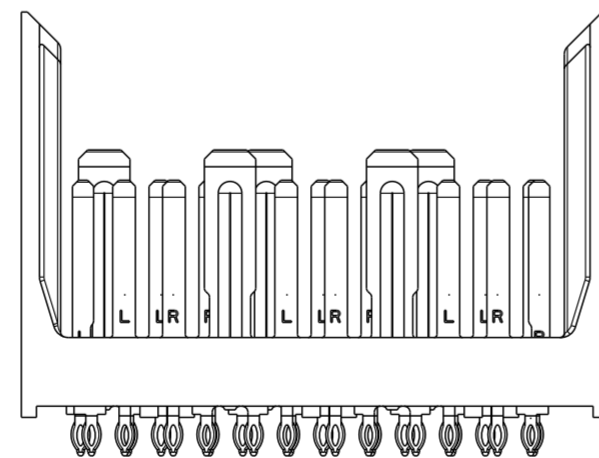

spec ref	-	dr	Roger Ng	2011/11/22	projection	MM	size	A2	scale	4:1									
tolerance std	ASME Y14.5	eng	Sandar Soe	2014/10/02			ecn no	ELX-S-18843-1	rel level	Released									
TOLERANCES UNLESS OTHERWISE SPECIFIED		chr	-	appr							Chen-Hong Tan	2014/12/10	product family	XCEDE					
surface	<table border="1"> <tr> <td>linear</td> <td>0.X</td> <td>±0.2</td> </tr> <tr> <td></td> <td>0.XX</td> <td>±0.10</td> </tr> <tr> <td></td> <td>0.XXX</td> <td>±0.050</td> </tr> <tr> <td>angular</td> <td>0°</td> <td>±2°</td> </tr> </table>	linear	0.X	±0.2		0.XX	±0.10		0.XXX	±0.050	angular	0°	±2°			TITLE MODULE ASSEMBLY VERTICAL HEADER 4 COLUMN, 3 PAIR		dwg no 10119187	rev B
linear	0.X	±0.2																	
	0.XX	±0.10																	
	0.XXX	±0.050																	
angular	0°	±2°																	
www.fci.com		cat. no.		Product - Customer Draw		sheet 2 of 8													

LEFT POLARIZING/GUIDE MODULE

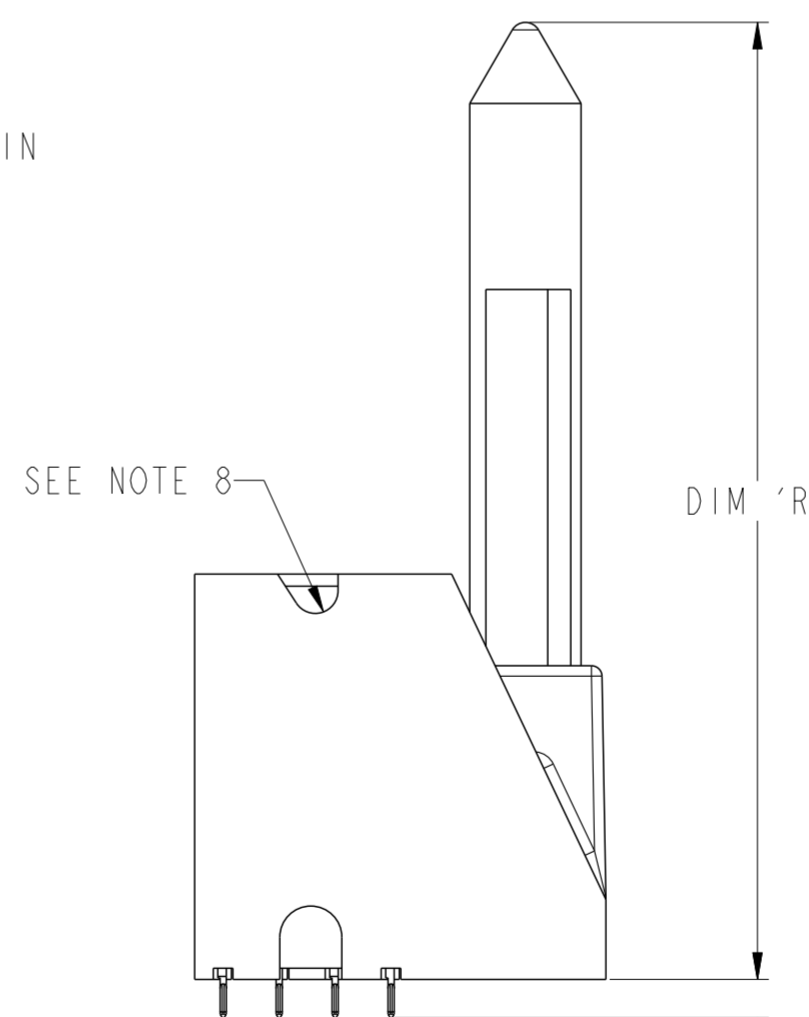
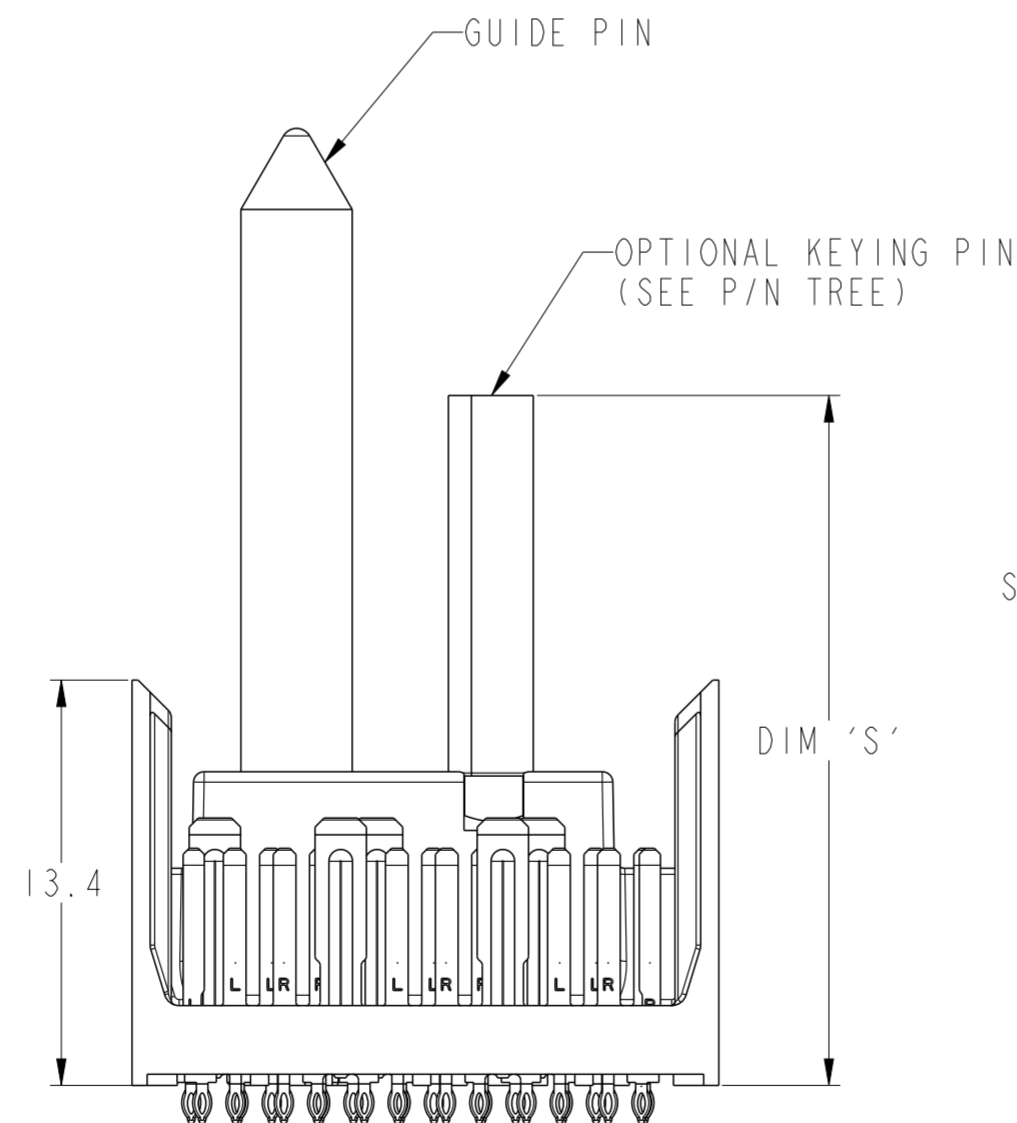
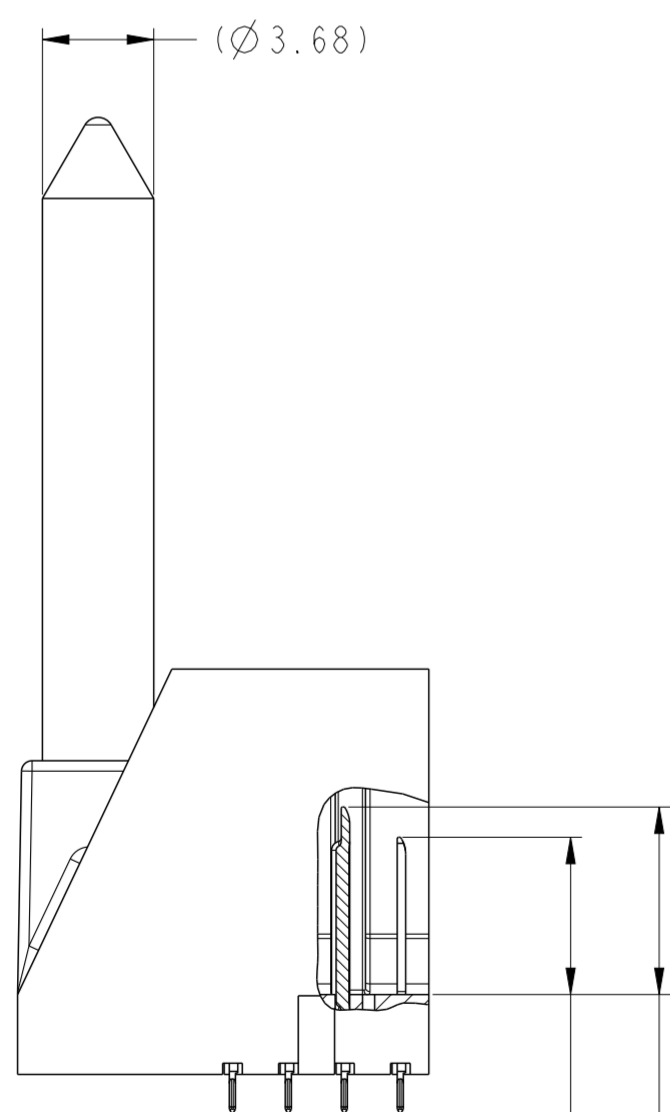
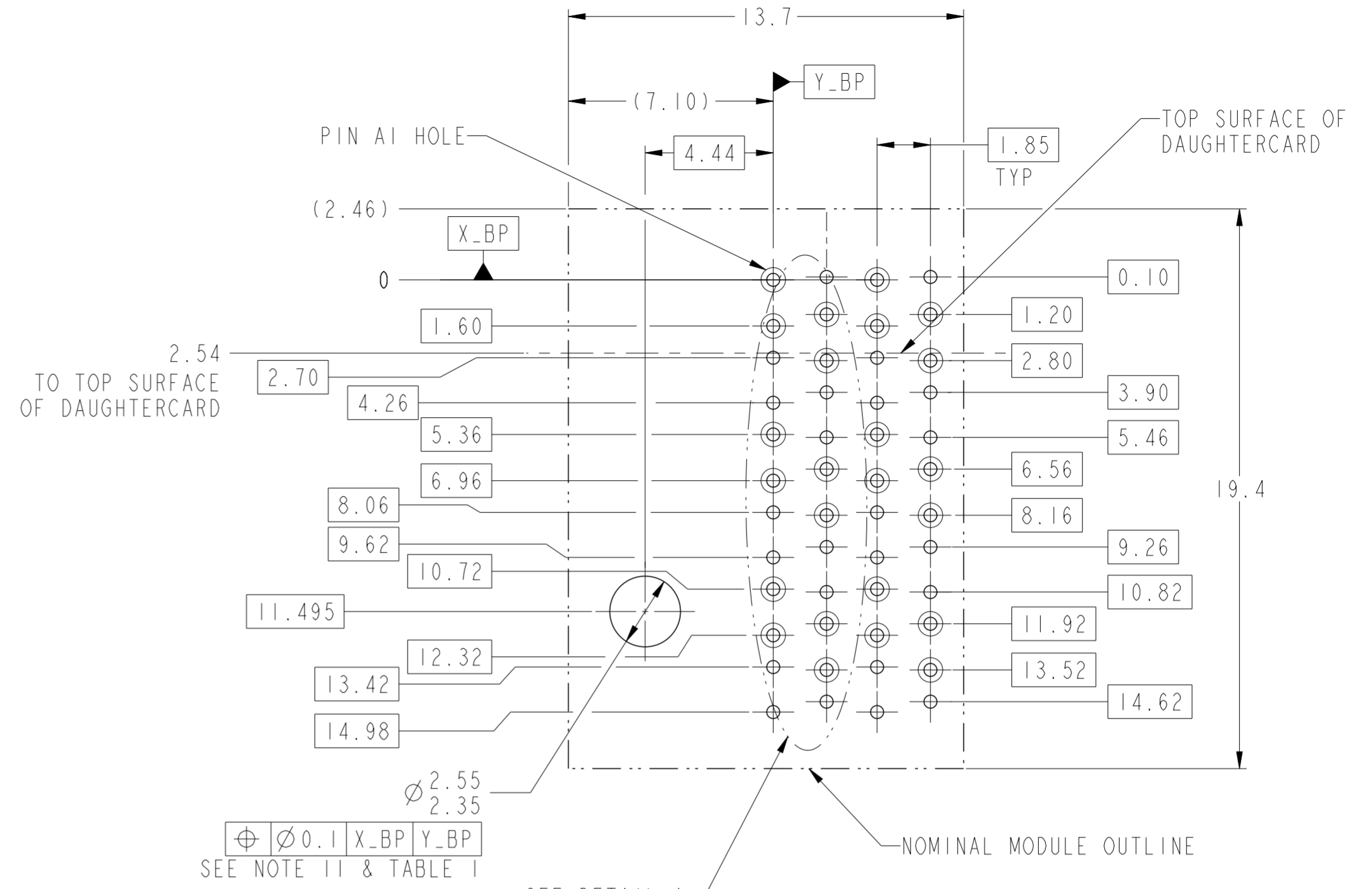
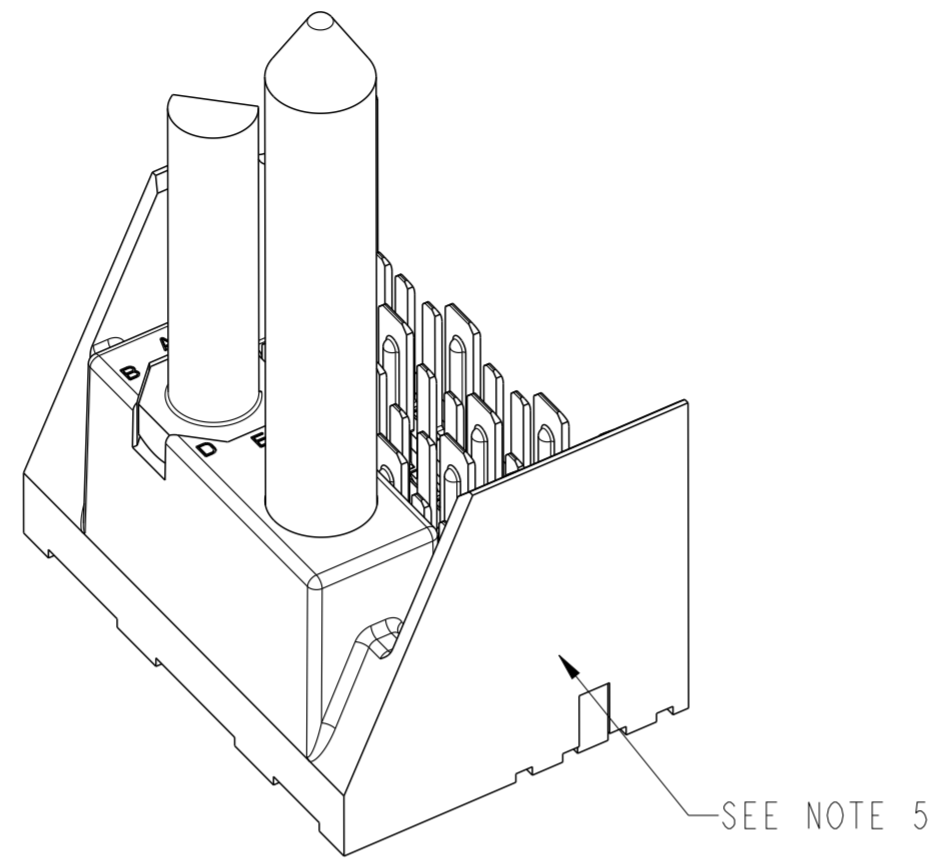
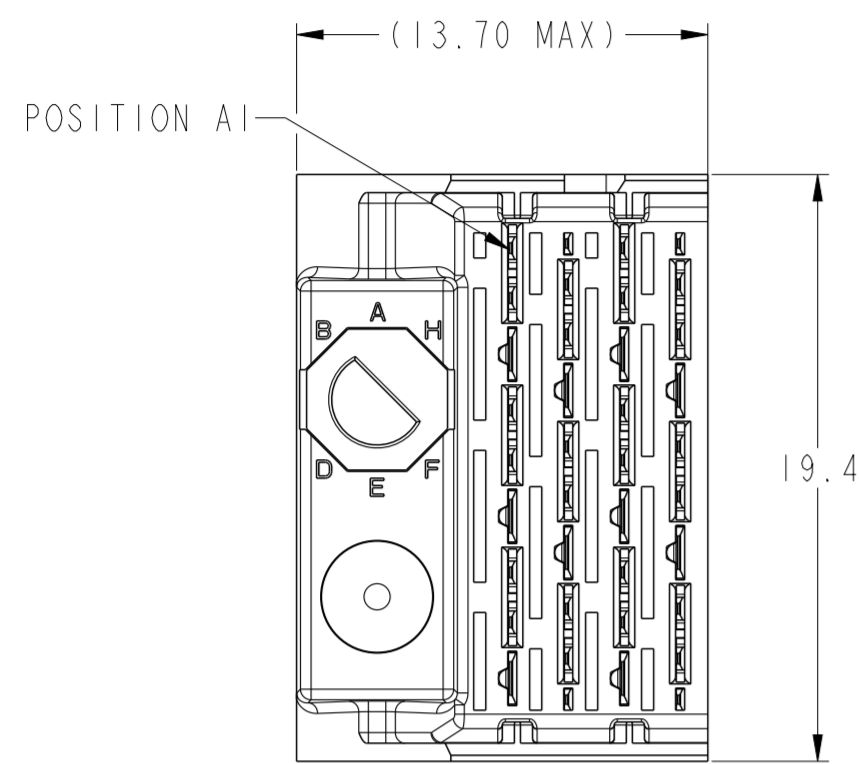

ASSEMBLY BASE CONFIGURATION END DASH NO.	GUIDE PIN	POLARIZING KEY
	DIM 'R'	DIM 'S'
-X0X	31.6mm	22.8mm
-X4X	25.7mm	20.0mm

- 5.2 (3MM SMALL END GROUNDS)
- 5.2 (3MM WIPE SIGNALS)
- 4.2 (2MM WIPE SIGNALS)  
SEE P/N TREE
- 6.2 (4MM WIPE WIDE GROUNDS)
- 5.2 (3MM WIPE WIDE GROUNDS)

TAIL LENGTH  
SEE NOTE 12

spec ref	-	dr	Roger Ng	2011/11/22	projection	MM	size	A2	scale	4:1
tolerance std	ASME Y14.5	eng	Sandar Soe	2014/10/02	chr	-	ecn no	ELX-S-18843-1	rel level	Released
surface	linear	appr	Chen-Hong Tan	2014/12/10	product family	XCEDE	cat. no.	Product - Customer Drw	sheet	3 of 8
ASME Y14.5	angular	0°	±2°	0.X	±0.2	0.XX	±0.10	0.XXX	±0.050	

Copyright FCI. FCI

RIGHT POLARIZING/GUIDE MODULE

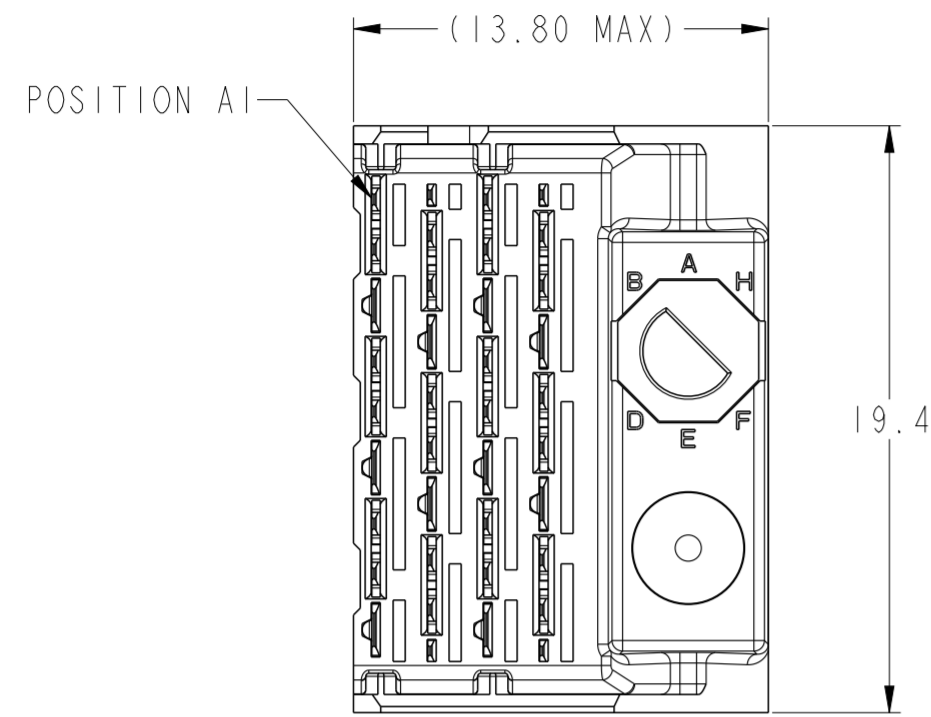

SEE NOTE 8

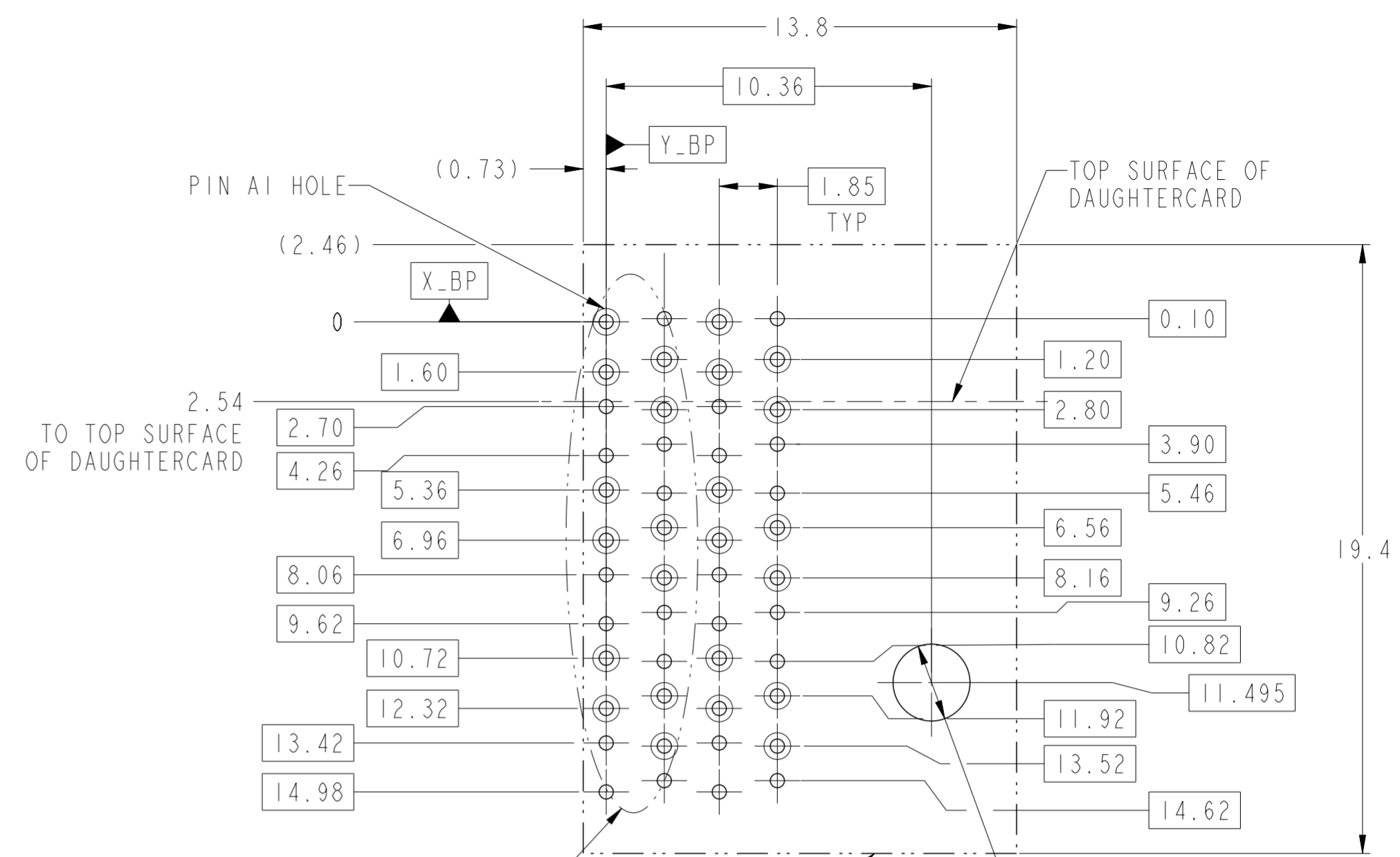
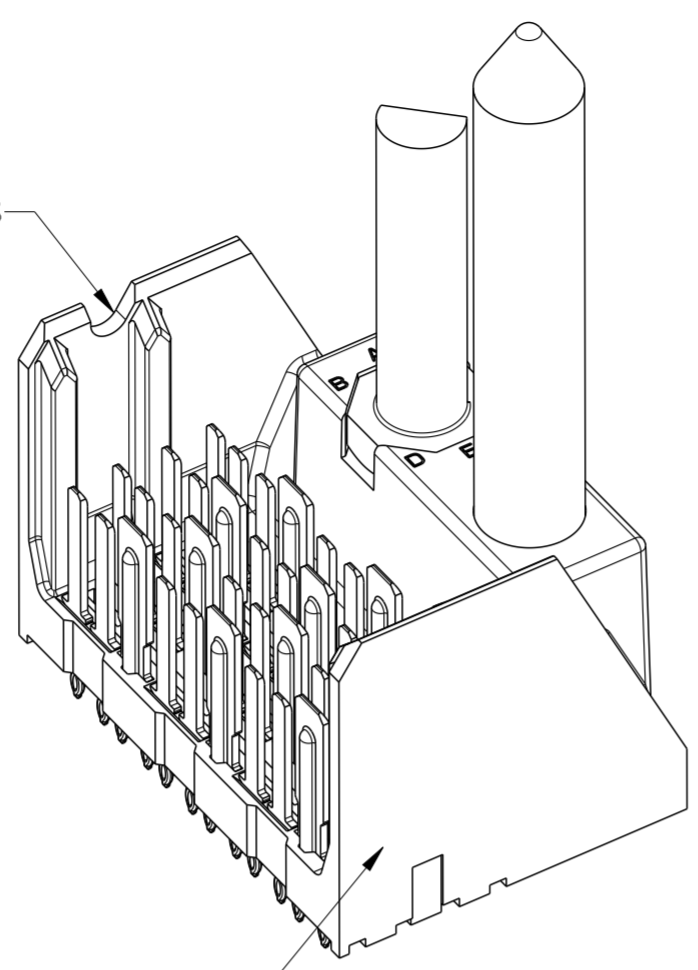

$\varnothing 2.55$   
 $\varnothing 2.35$   
 $\varnothing 0.1$  X\_BP Y\_BP  
 SEE NOTE 11 & TABLE 1

$(\varnothing 3.68)$

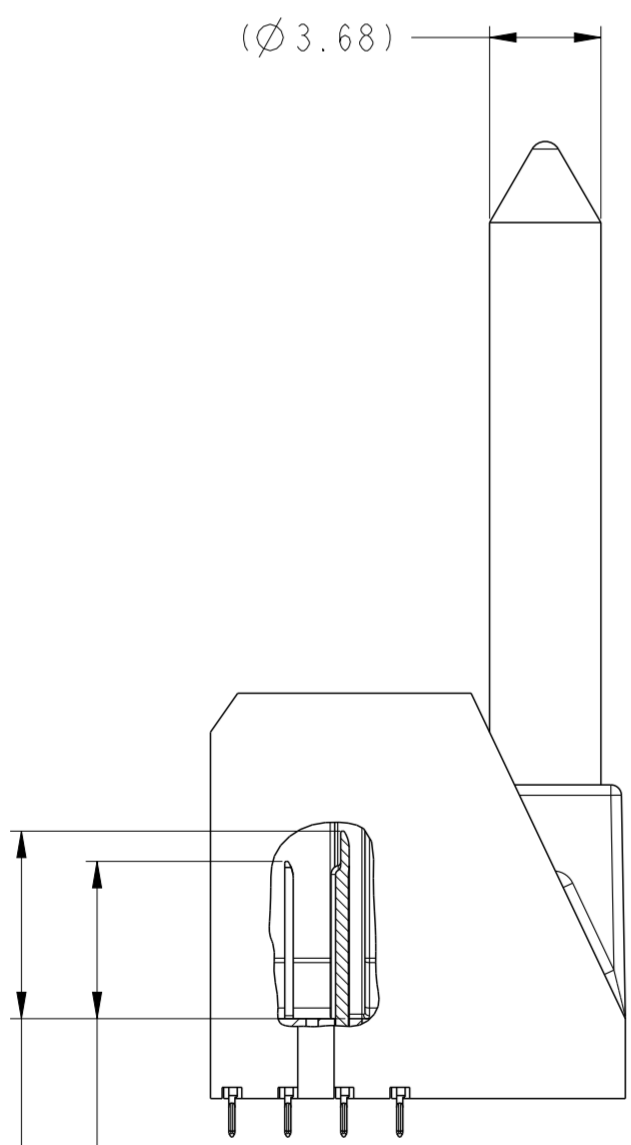

GUIDE PIN

OPTIONAL KEYING PIN  
(SEE P/N TREE)

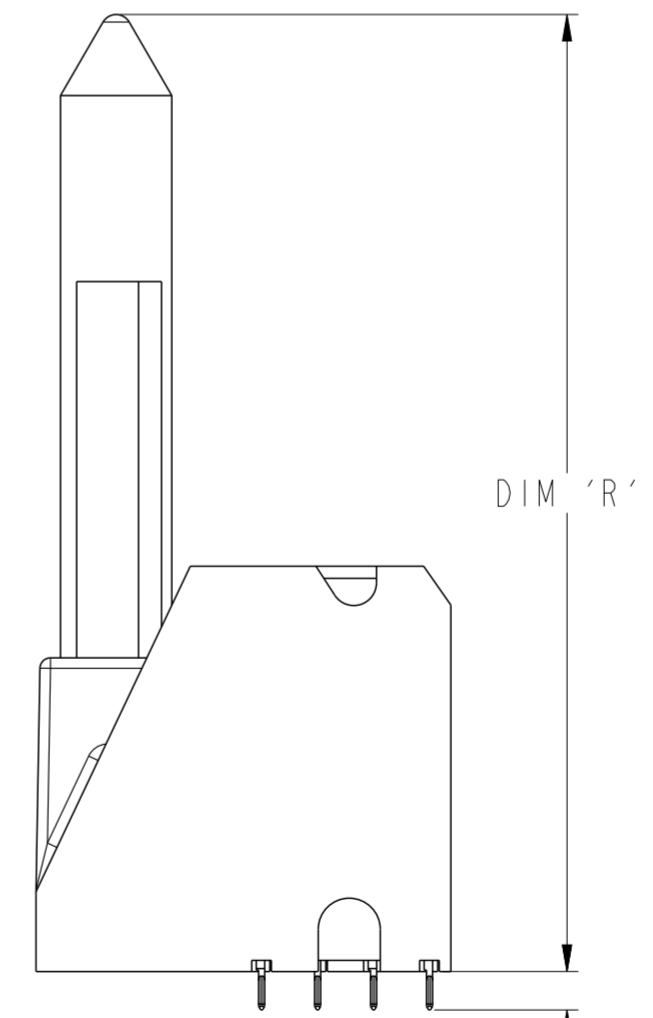
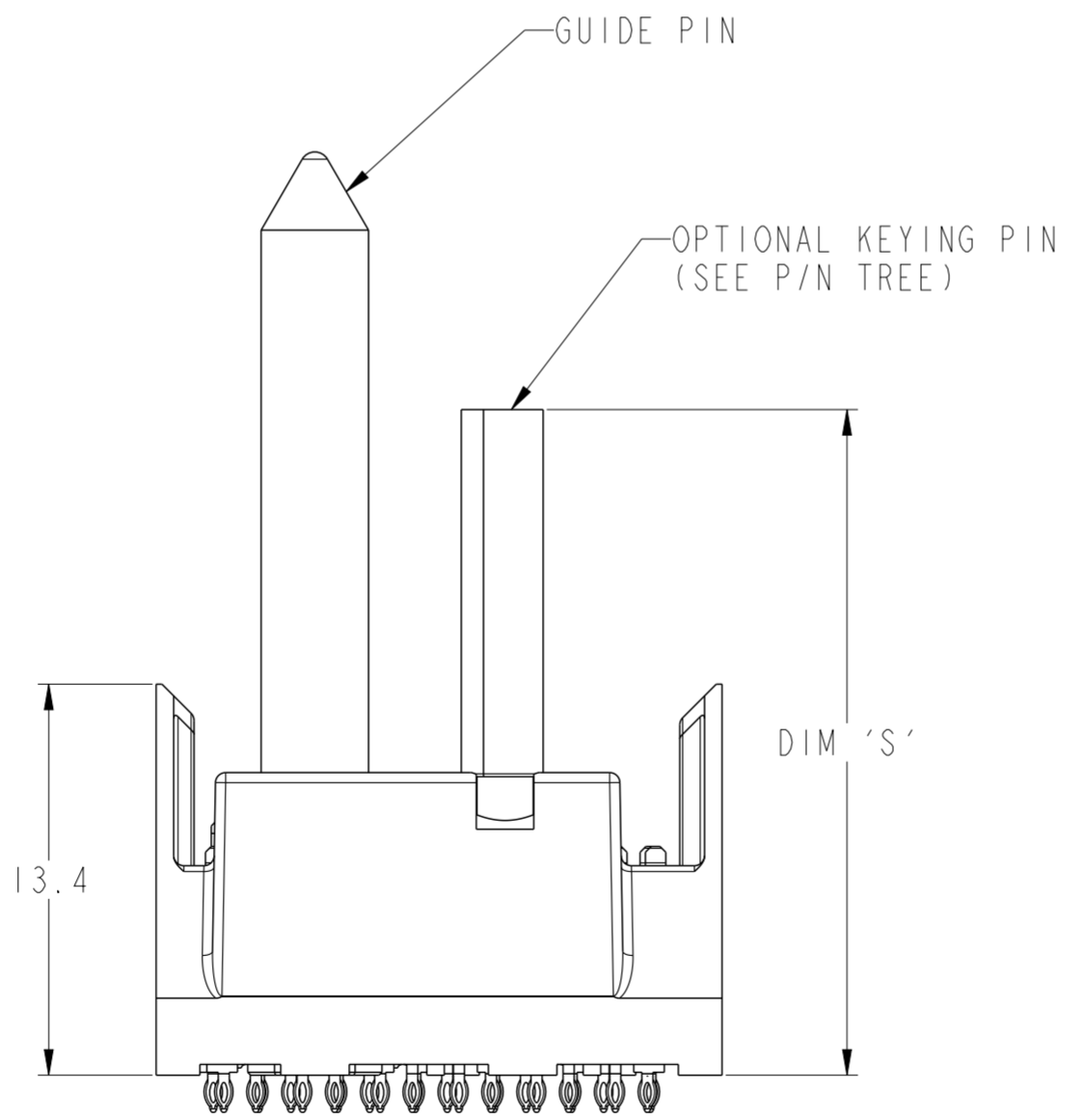

TAIL LENGTH  
SEE NOTE 12  $\triangle B$

- 5.2 (3MM SMALL END GROUNDS)
- 5.2 (3MM WIPE SIGNALS)
- 4.2 (2MM WIPE SIGNALS)
- SEE P/N TREE
- 6.2 (4MM WIPE WIDE GROUNDS)
- 5.2 (3MM WIPE WIDE GROUNDS)

ASSEMBLY BASE CONFIGURATION END DASH NO.	GUIDE PIN	POLARIZING KEY
	DIM 'R'	DIM 'S'
-X0X	31.6mm	22.8mm
-X4X	25.7mm	20.0mm

spec ref	-	dr	Roger Ng	2011/1/22	projection	MM	size	A2	scale	4:1
tolerance std	ASME Y14.5	eng	Sandar Soe	2014/10/02	chr	-	ecn no	ELX-S-18843-1	rel level	Released
surface	linear	appr	Chen-Hong Tan	2014/12/10	product family	XCEDE	cat. no.	10119187	rev	B
	angular						Product - Customer Drw	sheet 4 of 8		

PDS: Rev :B

STATUS:Released

Printed: Dec 10, 2014

Copyright FCI. FCI

LEFT WALL MODULE

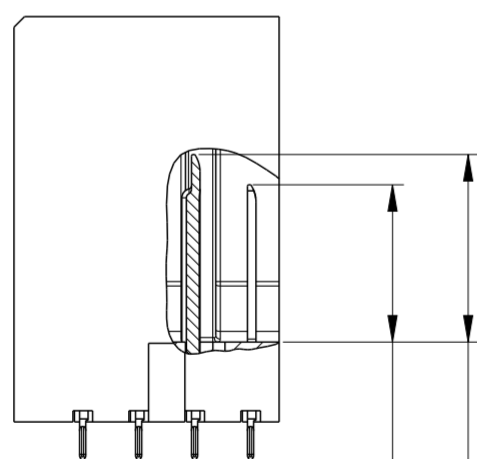
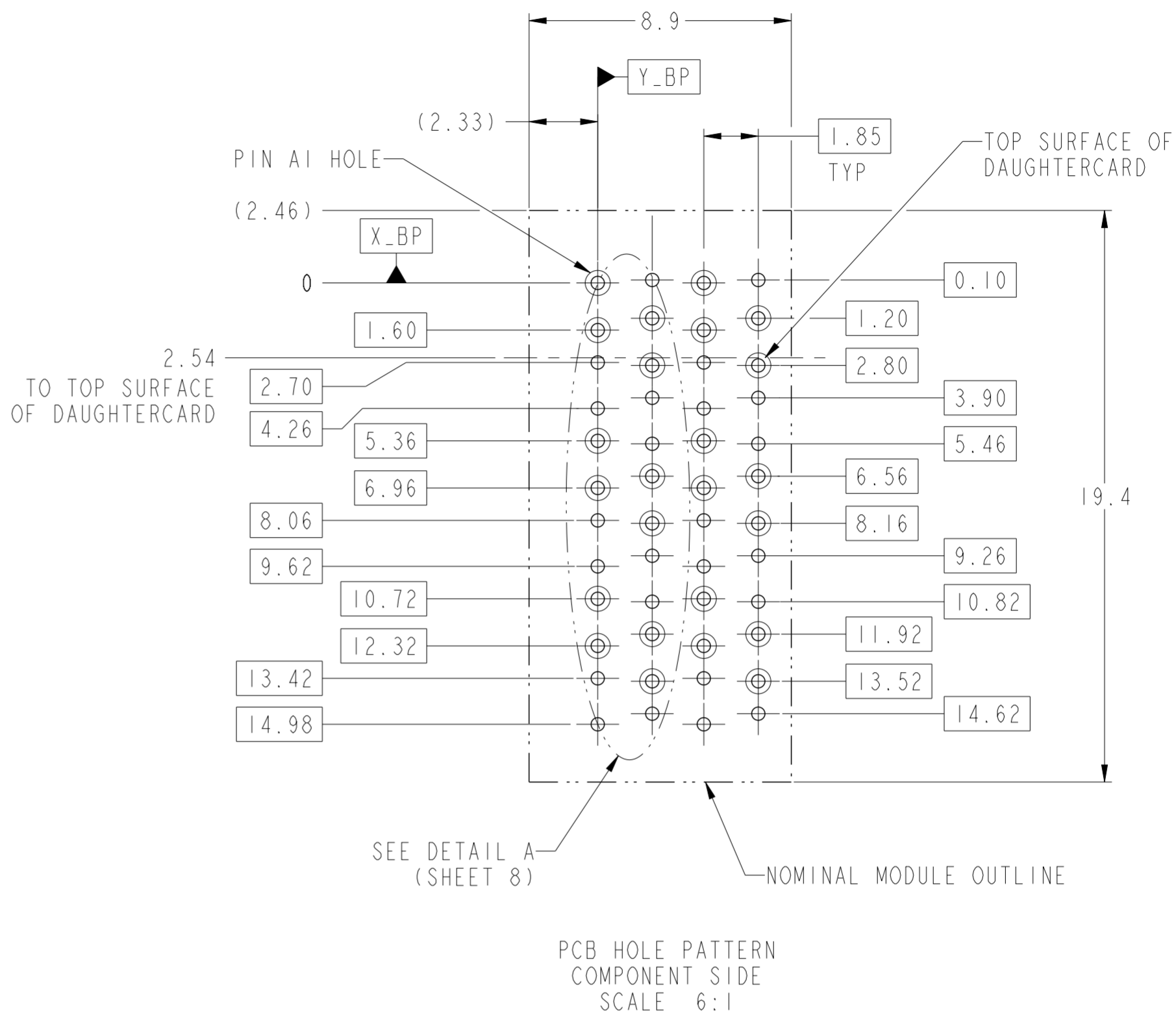
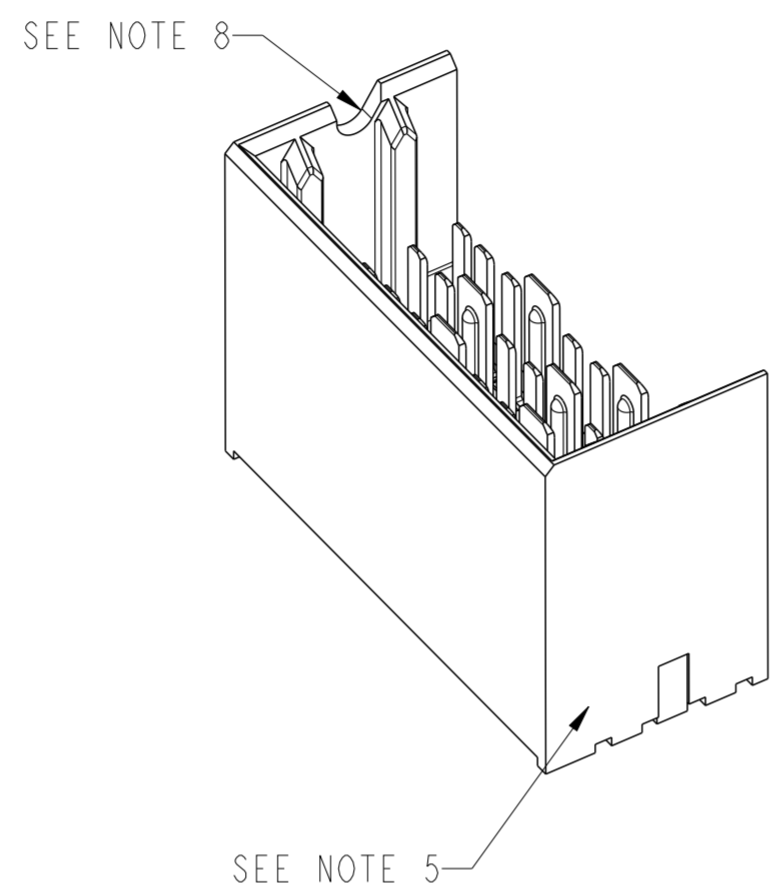
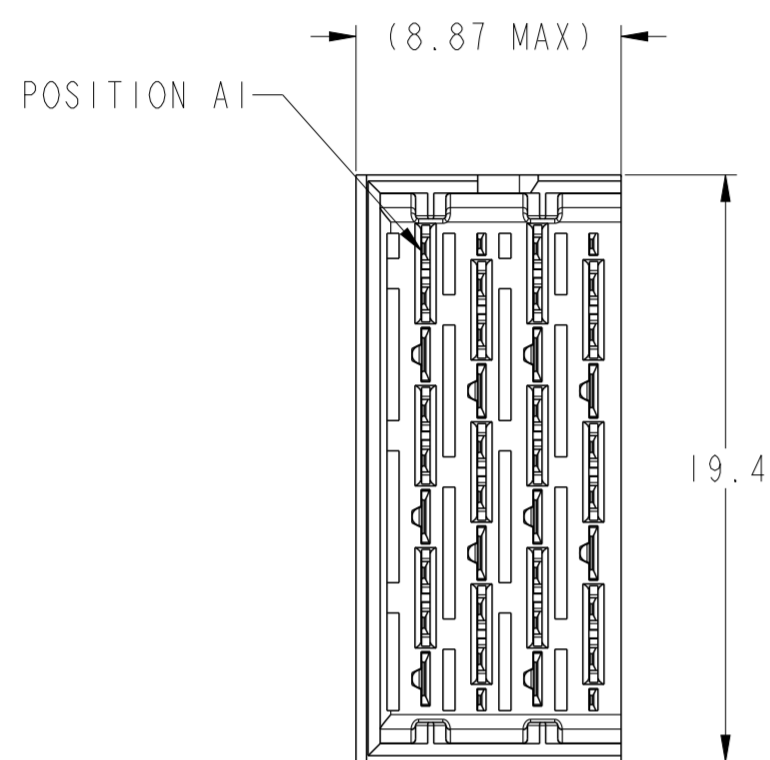

- 5.2 (3MM SMALL END GROUNDS)
- 5.2 (3MM WIPE SIGNALS)
- 4.2 (2MM WIPE SIGNALS)
- SEE P/N TREE
- 6.2 (4MM WIPE WIDE GROUNDS)
- 5.2 (3MM WIPE WIDE GROUNDS)

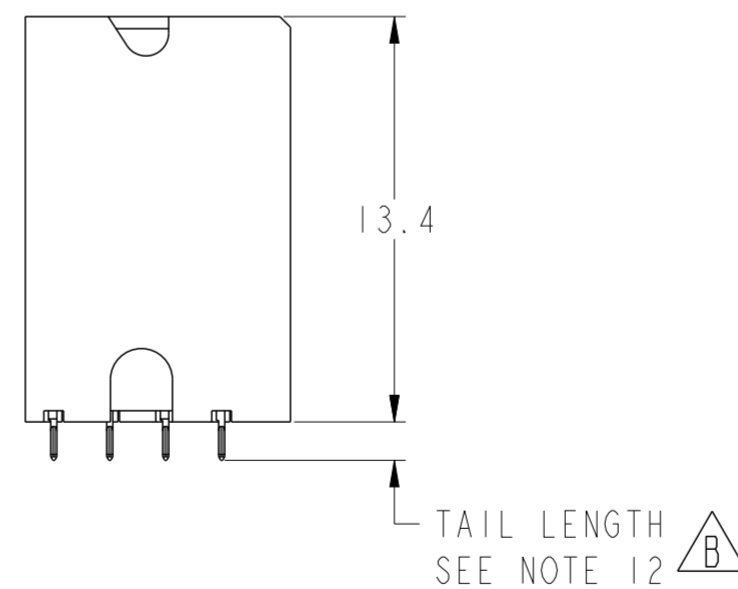
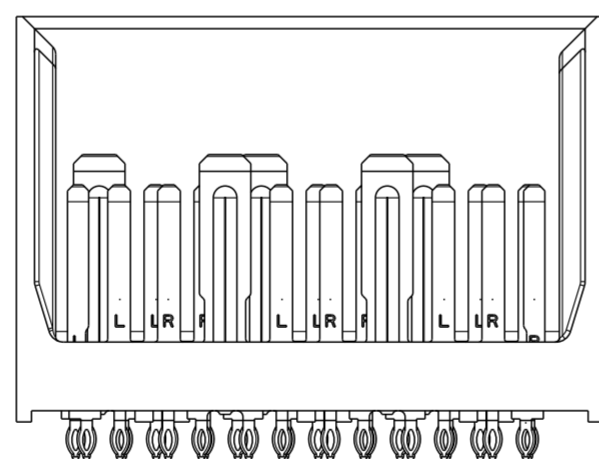

spec ref	-	dr	Roger Ng	2011/11/22	projection	MM	size	A2	scale	4:1
tolerance std	ASME Y14.5	eng	Sandar Soe	2014/10/02			ecn no	ELX-S-18843-1		
TOLERANCES UNLESS OTHERWISE SPECIFIED		chr	-	appr			Chen-Hong Tan	2014/12/10	product family	XCEDE
surface	ASME Y14.5	linear	0.X	±0.2		<b>MODULE ASSEMBLY</b> VERTICAL HEADER 4 COLUMN, 3 PAIR	dwg no	10119187		
		0.XX	±0.10	cat. no.			-	Product - Customer Drw	sheet 5 of 8	
		0.XXX	±0.050	angular			0°	±2°		



RIGHT WALL MODULE

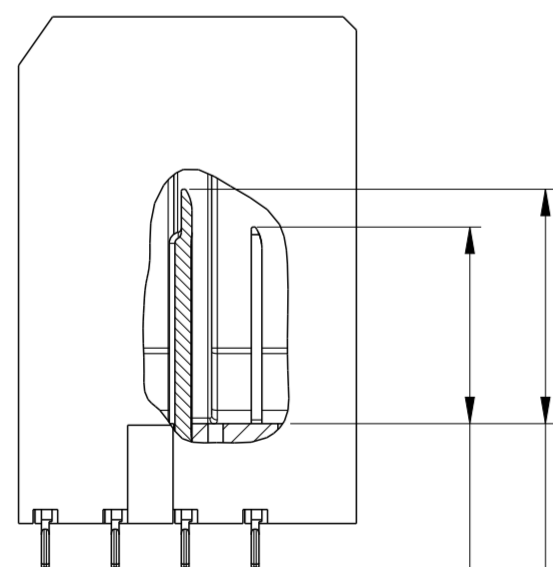
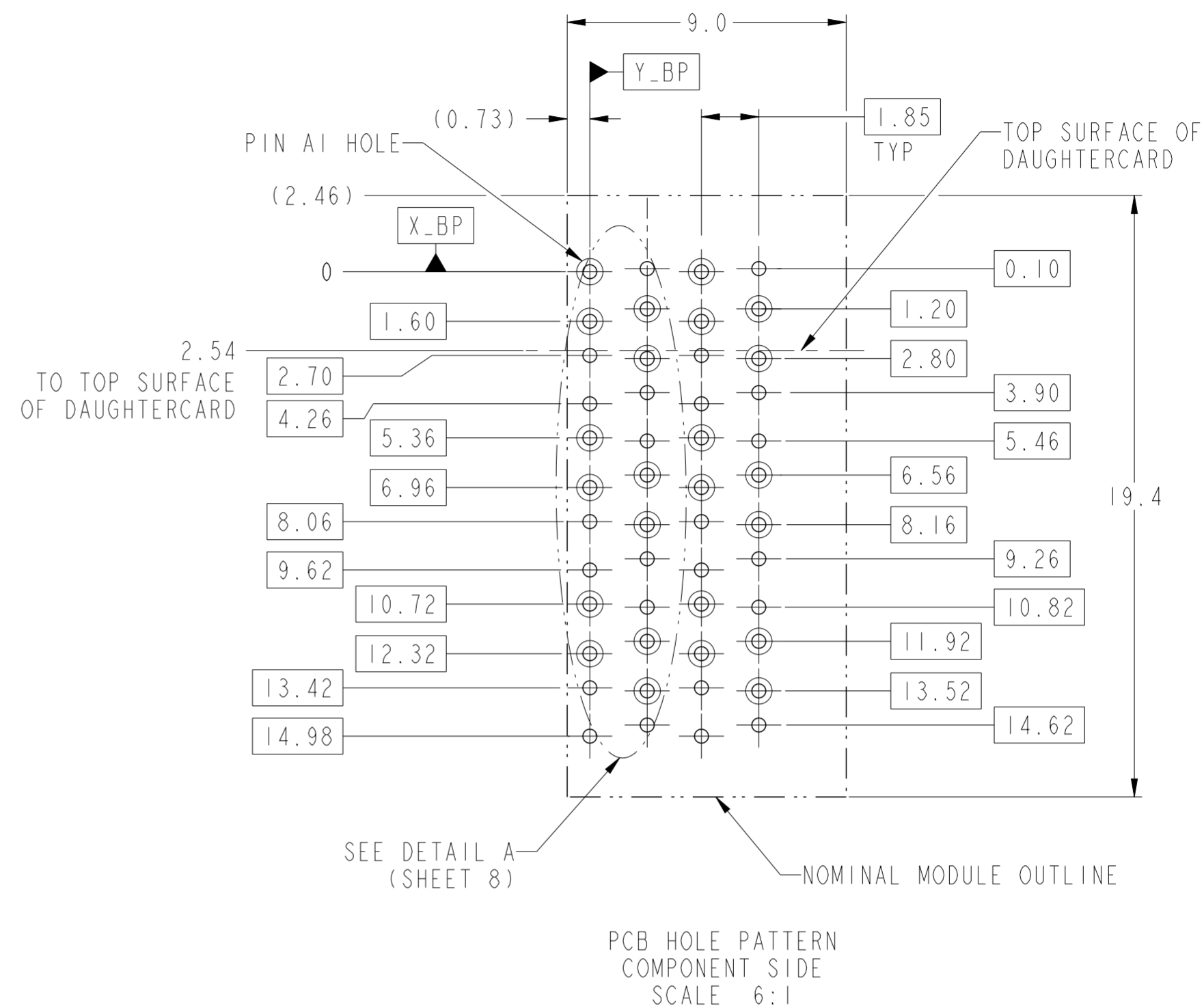
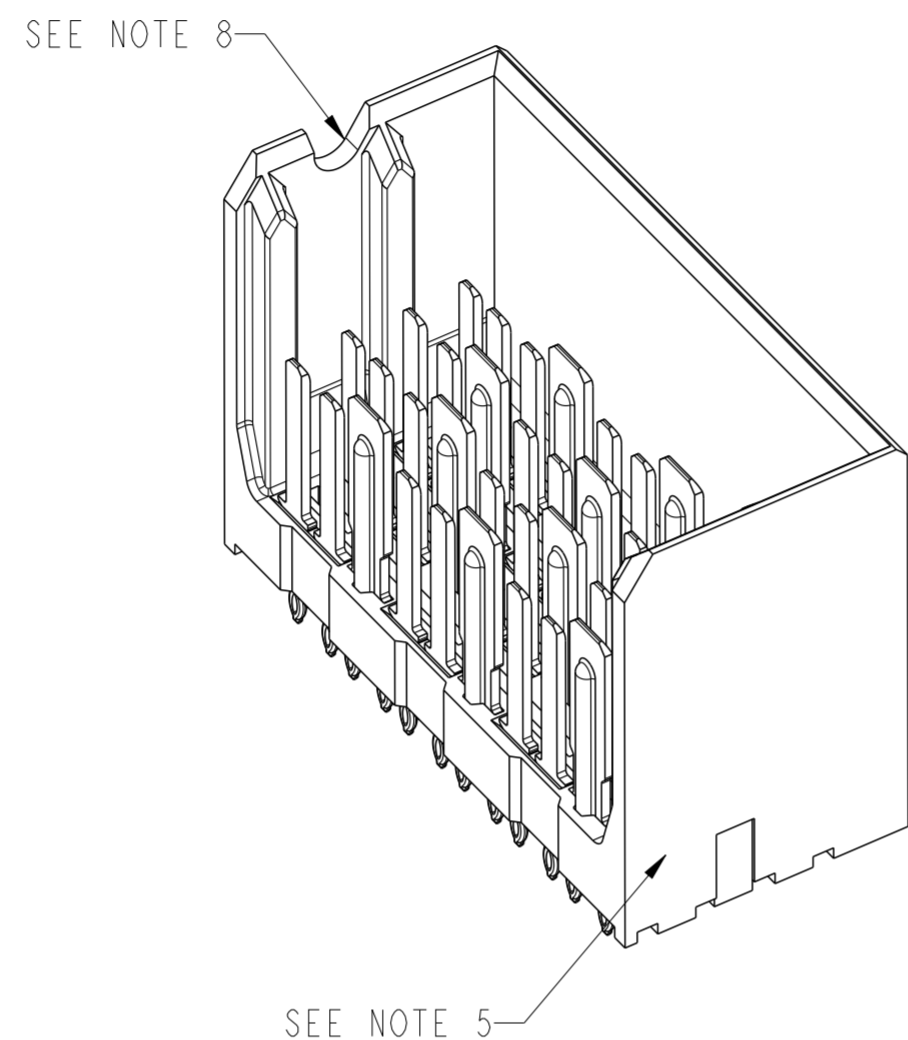
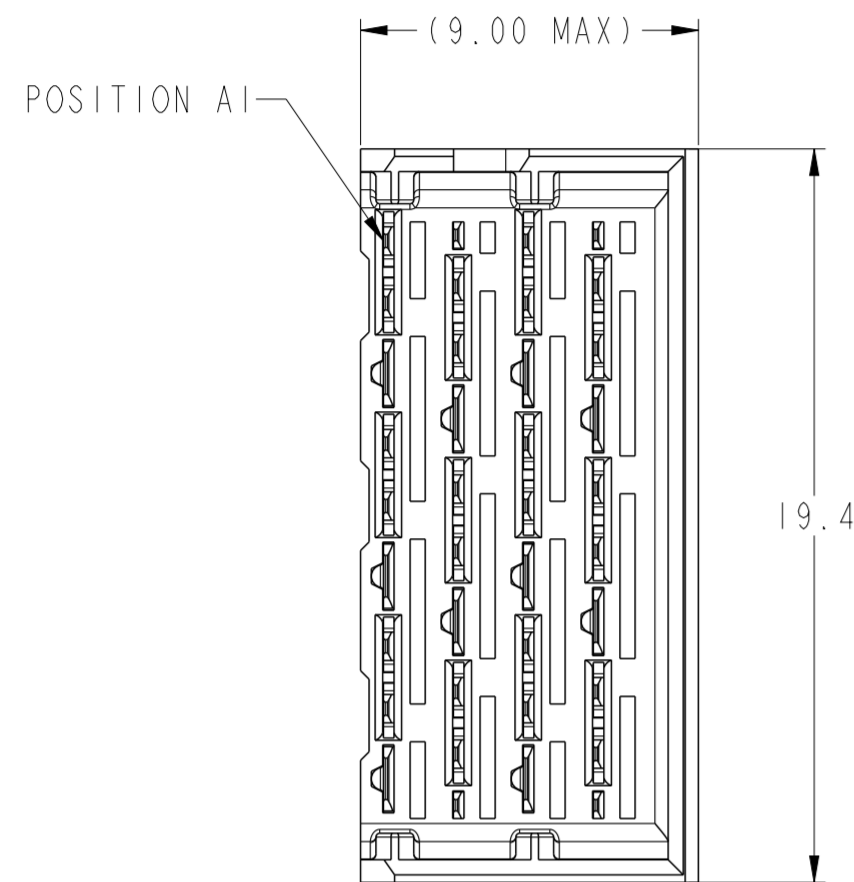

- 5.2 (3MM SMALL END GROUNDS)
- 5.2 (3MM WIPE SIGNALS)
- 4.2 (2MM WIPE SIGNALS)
- SEE P/N TREE
- 6.2 (4MM WIPE WIDE GROUNDS)
- 5.2 (3MM WIPE WIDE GROUNDS)

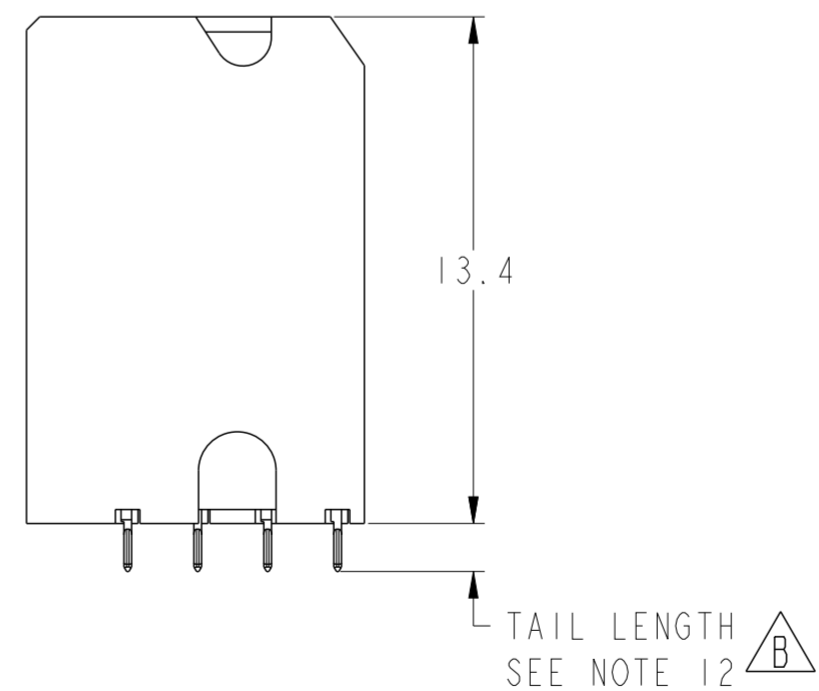
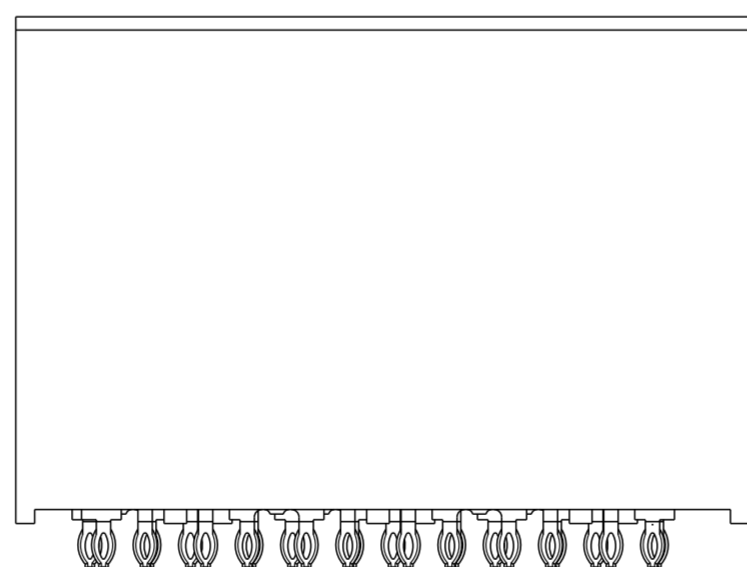

spec ref	-	dr	Roger Ng	2011/11/22	projection	MM	size	A2	scale	4:1									
tolerance std	ASME Y14.5	eng	Sandar Soe	2014/10/02			ecn no	ELX-S-18843-1	rel level	Released									
TOLERANCES UNLESS OTHERWISE SPECIFIED		chr	-	appr							Chen-Hong Tan	2014/12/10	product family	XCEDE					
surface	<table border="1"> <tr> <td>linear</td> <td>0.X</td> <td>±0.2</td> </tr> <tr> <td></td> <td>0.XX</td> <td>±0.10</td> </tr> <tr> <td></td> <td>0.XXX</td> <td>±0.050</td> </tr> <tr> <td>angular</td> <td>0°</td> <td>±2°</td> </tr> </table>	linear	0.X	±0.2		0.XX	±0.10		0.XXX	±0.050	angular	0°	±2°			title MODULE ASSEMBLY VERTICAL HEADER 4 COLUMN, 3 PAIR		dwg no 10119187	rev B
linear	0.X	±0.2																	
	0.XX	±0.10																	
	0.XXX	±0.050																	
angular	0°	±2°																	
ASME Y14.5		www.fci.com		cat. no.	-		Product - Customer Drw		sheet 6 of 8										

FOUR WALL MODULE

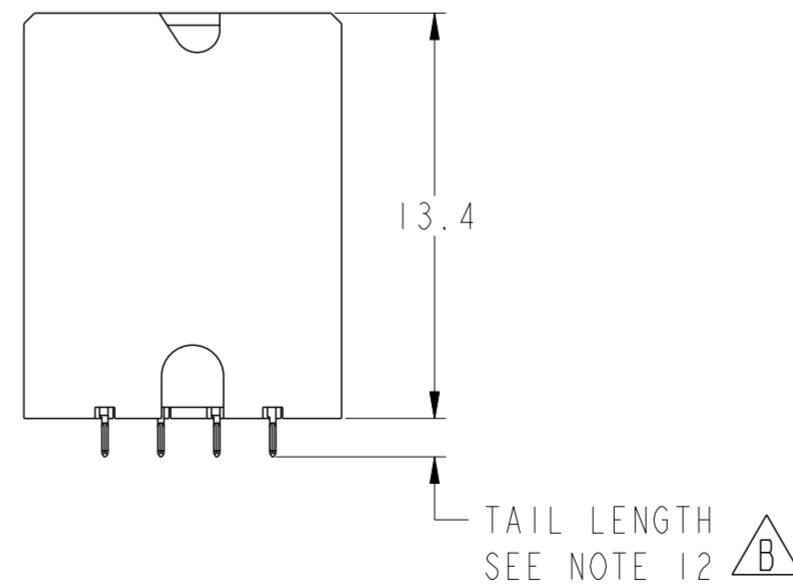
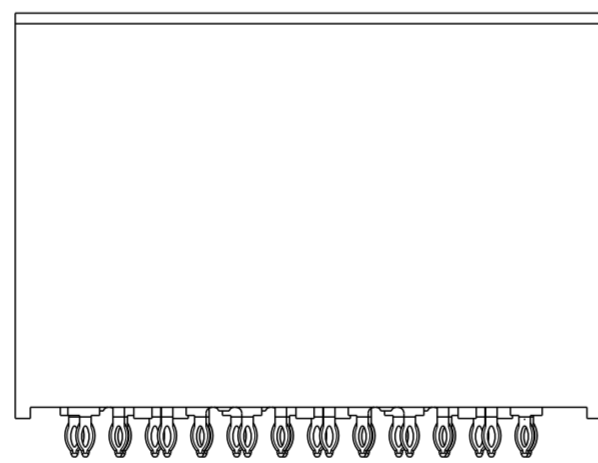
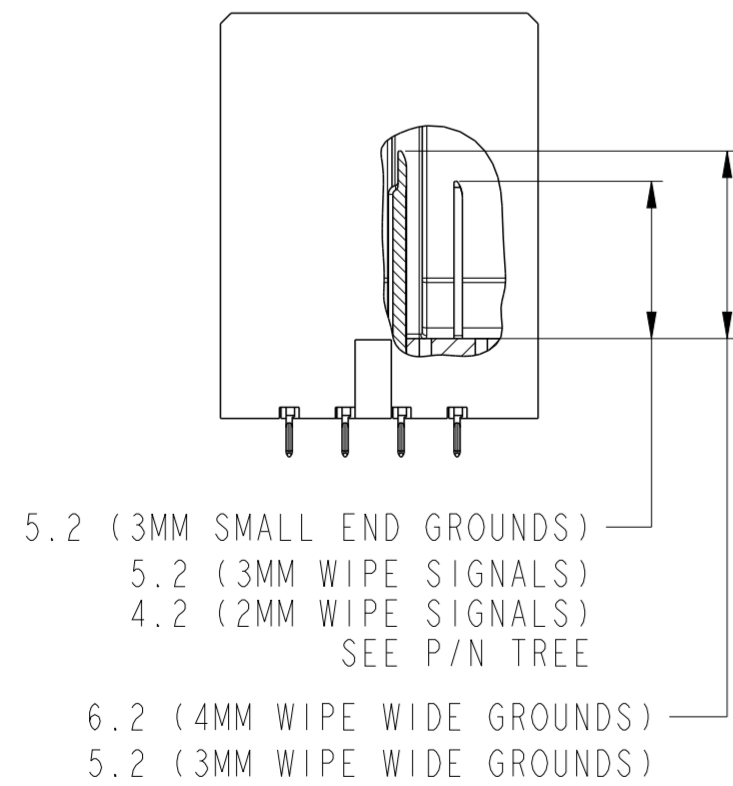
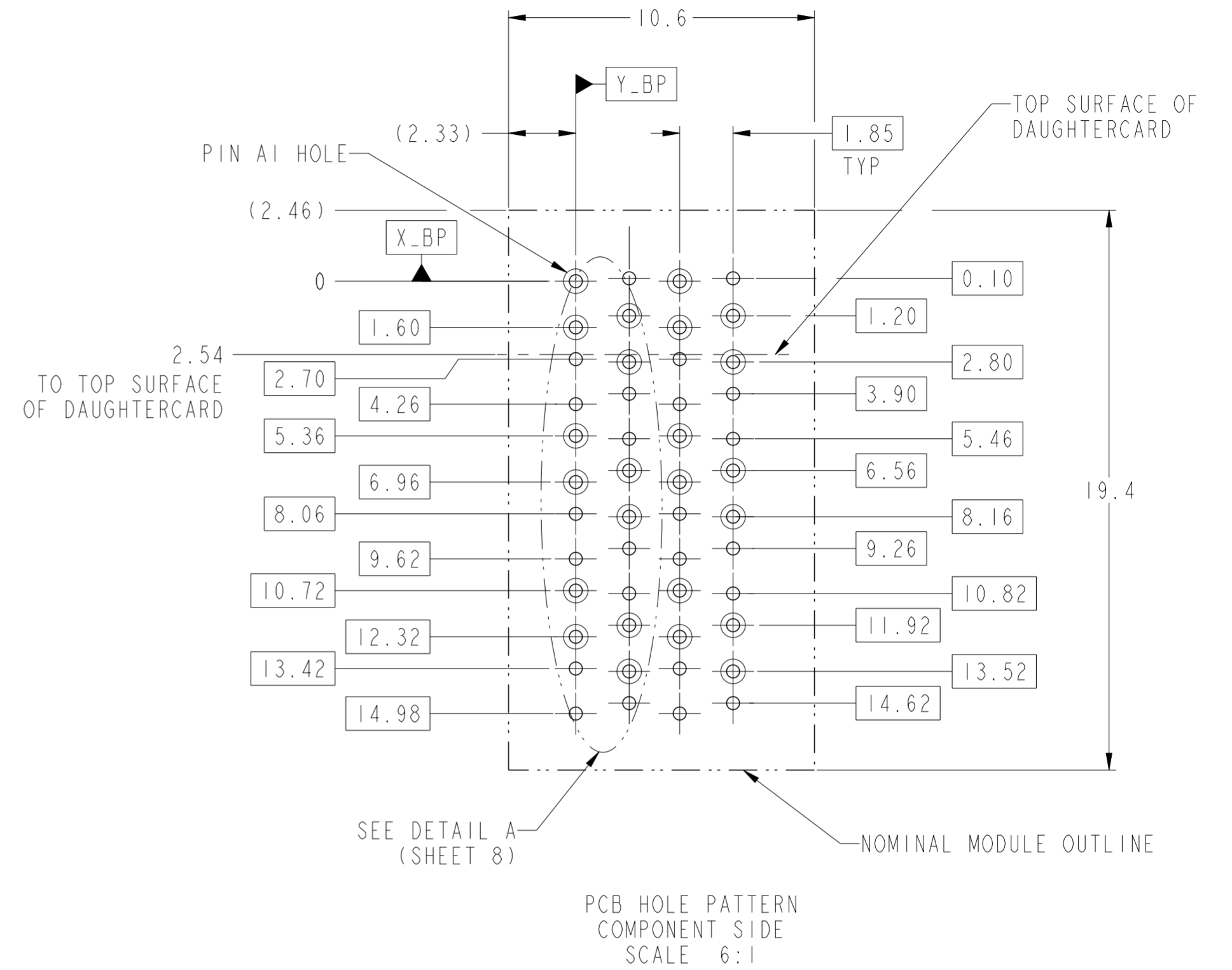
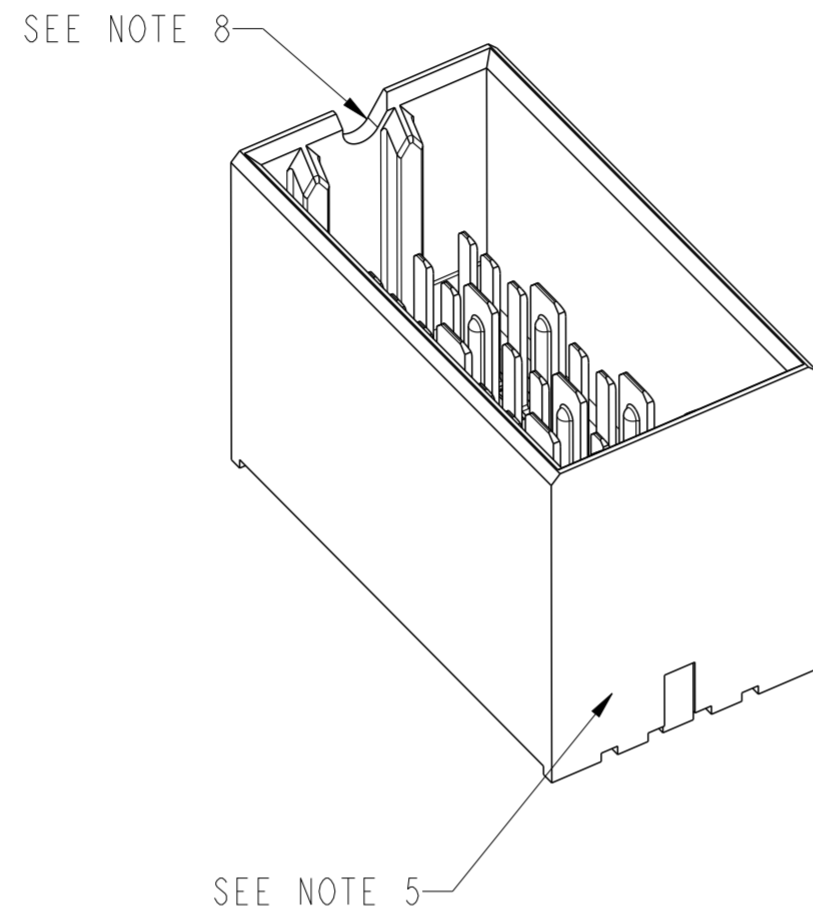
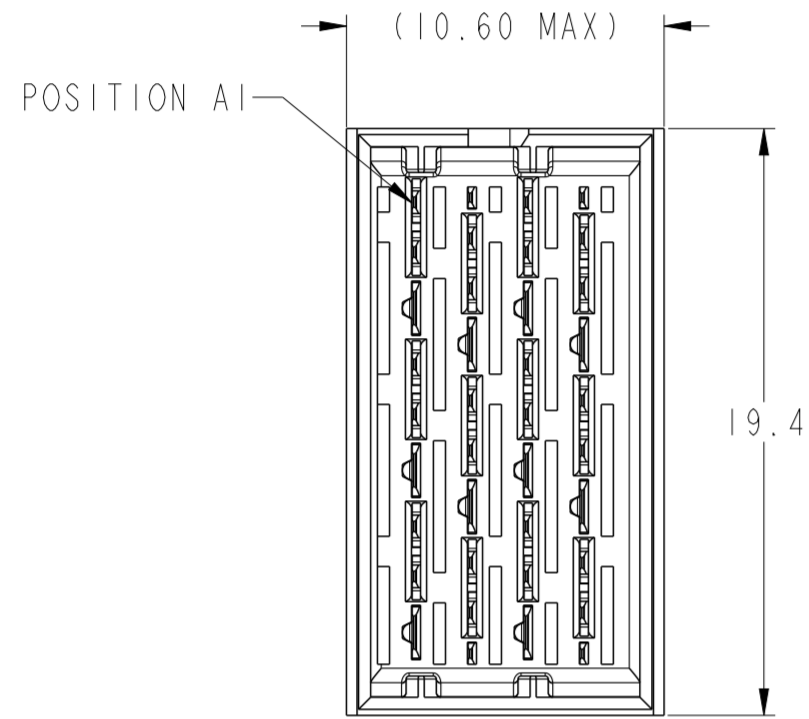

spec ref	-	dr	Roger Ng	2011/11/22	projection	MM	size	A2	scale	4:1		
tolerance std	ASME Y14.5	eng	Sandar Soe	2014/10/02			ecn no	ELX-S-18843-1				
TOLERANCES UNLESS OTHERWISE SPECIFIED		chr	-	appr			Chen-Hong Tan	2014/12/10	product family	XCEDE		
surface	ASME Y14.5	linear	0.X	±0.2	0.XX	±0.10	0.XXX	±0.050		TITLE MODULE ASSEMBLY VERTICAL HEADER 4 COLUMN, 3 PAIR	dwg no 10119187	rev B
angular	0°	±2°	www.fci.com		cat. no.	-	Product - Customer Drw	sheet 7 of 8				

NOTES:

1. CONNECTOR MATERIALS  
SHROUD: HIGH-TEMP THERMOPLASTIC, GRAY, UL94V-0  
CONTACTS: HIGH PERFORMANCE COPPER ALLOY
2. CONTACT PLATING:  
  
SEPARABLE INTERFACE: PERFORMANCE-BASED PLATING, QUALIFIED TO MEET THE REQUIREMENTS OF FCI PRODUCT SPECIFICATION GS-12-588, INCLUDING THE TELCORDIA GR-1217-CORE (NOVEMBER 1995) CENTRAL OFFICE (CO) OR UNCONTROLLED ENVIRONMENT (UE) TEST SEQUENCE AS NOTED IN P/N TREE.  
  
PRESS-FIT TAILS: TIN OVER NICKEL (LF), OR TIN-LEAD ALLOY OVER NICKEL (NON-LF). SEE P/N TREE.
3. PRODUCT SPECIFICATION: GS-12-588
4. APPLICATION SPECIFICATION: GS-20-121
5. PRODUCT MARKING (PART NUMBER AND LOT CODE) ON THESE SURFACES.
6. HOUSING MUST WITHSTAND EXPOSURE TO 260°C PEAK TEMPERATURE FOR 40 SECONDS IN A CONVECTION, INFRA-RED, OR VAPOR-PHASE REFLOW OVEN.
7. PACKAGING MEETS GS-14-920 LEAD-FREE LABELING SPECIFICATION.
8. NOTCH INDICATES "ROW A" SIDE OF CONNECTOR.
9. SEE APPLICATION SPECIFICATION FOR ROUTING GUIDELINES, ADDITIONAL PTH GUIDELINES, MATED DIMENSIONS, GUIDE PN SELECTION, ETC.
10. SCREW IS OPTIONAL AND ENGAGES WITH BOTTOM OF GUIDE-PIN FROM BENEATH THE PCB FOR ADDITIONAL GUIDE-PIN SUPPORT.
11. OPTIONAL HOLE LOCATION FOR GROUNDED PIN OR ADDITIONAL GUIDE-PIN SUPPORT. SEE TABLE 1 ON SHEET 1 FOR ADDITIONAL DETAILS.
12. TAIL LENGTH=1.3mm FOR  $\varnothing 0.55$ [0.0217"]COMPLIANT PIN DRILL  
TAIL LENGTH=1.5mm FOR  $\varnothing 0.45$ [0.0177"]COMPLIANT PIN DRILL
13. A  $\triangle$  SYMBOL WILL BE NEXT TO ANY DIMENSION, VIEW OR NOTE THAT HAS BEEN MODIFIED WITH THE CURRENT DRAWING REVISION.

TABLE 3: PTH AND PAD SIZES WITH REFERENCE TO COMPLIANT PIN DRILL		
COMPLIANT PIN DRILL	PTH	PAD
$\varnothing 0.55$ [0.0217"]	$\varnothing 0.45 \pm 0.05$	$\varnothing 0.85$
$\varnothing 0.45$ [0.0177"]	$\varnothing 0.36 \pm 0.05$	$\varnothing 0.75$

REFER TO TABLE 3 FOR PTH, DRILL & PAD SIZES

$\varnothing$	0.10	X_BP	Y_BP
---------------	------	------	------

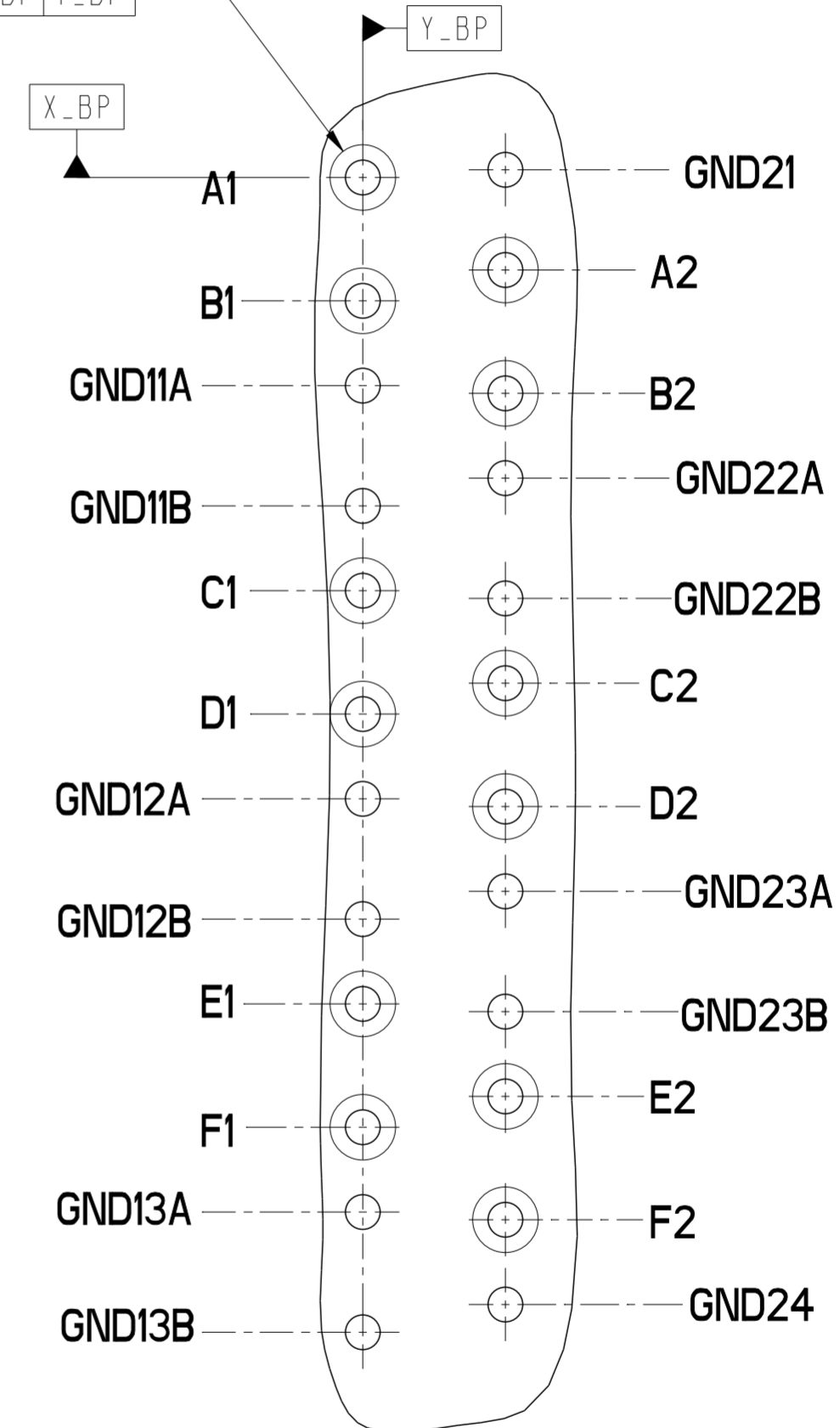

DETAIL A  
SCALE 12:1

spec ref	-	dr	Roger Ng	2011/11/22	projection	MM	size	A2	scale	4:1	
tolerance std	ASME Y14.5	eng	Sandar Soe	2014/10/02			ecn no	ELX-S-18843-1			
TOLERANCES UNLESS OTHERWISE SPECIFIED		chr	-	appr			Chen-Hong Tan	2014/12/10	product family	XCEDE	rel level
surface	✓	linear	0.X	±0.2		<b>MODULE ASSEMBLY</b> VERTICAL HEADER 4 COLUMN, 3 PAIR	cat. no.	-			
			0.XX	±0.10			Product	Customer Drw	sheet	8 of 8	
		angular	0°	±2°			www.fci.com	cat. no.	-		