

THIS DOCUMENT IS THE PROPERTY OF
KEYSTONE ELECTRONICS CORP. AND
SHALL NOT BE REPRODUCED, DISTRIBUTED
OR USED AS A BASIS FOR MANUFACTURE
WITHOUT PRIOR WRITTEN PERMISSION
FROM KEYSTONE ELECTRONICS CORP.

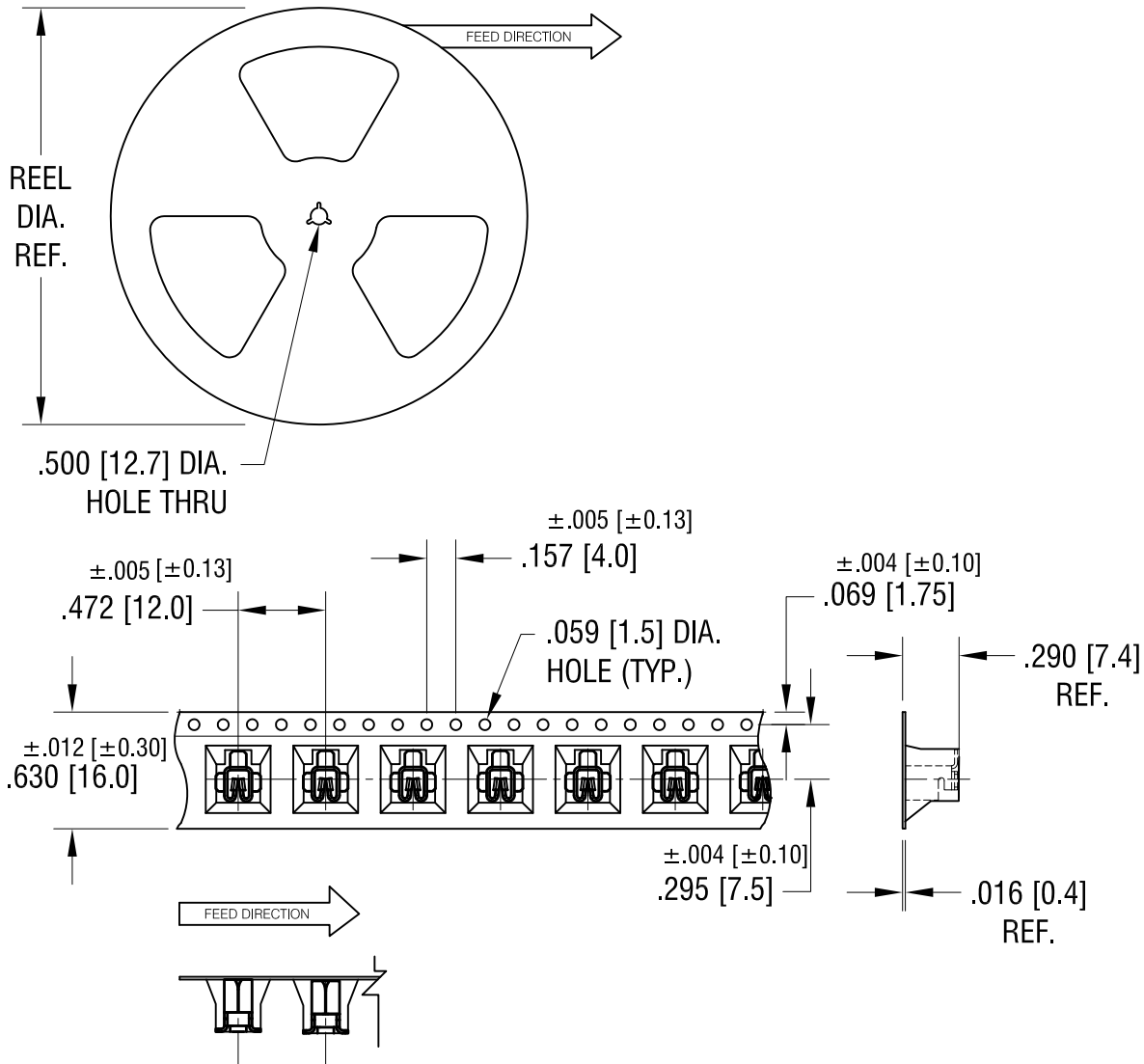

NOTES:

TAPE AND REEL SPECIFICATIONS:

1. TAPE:

MAT'L - ALL CONDUCTIVE POLYSTYRENE CARRIER
ANSI/EIA-481 STANDARD
.630 [16.0] WIDE; .472 [12.0] PITCH

2. REEL:

13.0 [330.2] DIA. 750 PIECES OF
PART NO. 3586 PER REEL.

KEYSTONE ELECTRONICS CORP.			
www.keyelco.com • ASTORIA, N.Y. 11105-2017 • Tel (718) 956-8900			
PART NAME			
SM UNIVERSAL AUTO FUSE, ON TAPE			
MATERIAL			
AS NOTED			
FINISH		DRN BY	DATE
AS NOTED		NT	10.7.09
		APP'D	SCALE
		LN	X
TOLERANCES	INCH	[MM]	CODE
DECIMAL	± .015	[± 0.38]	C
ANGULAR	± 1°		DWG NO.
UNLESS OTHERWISE SPECIFIED			3586TR

DATE	DESCRIPTION	REV.

THIS DOCUMENT IS THE PROPERTY OF KEYSTONE ELECTRONICS CORP. AND SHALL NOT BE REPRODUCED, DISTRIBUTED OR USED AS A BASIS FOR MANUFACTURE WITHOUT PRIOR WRITTEN PERMISSION FROM KEYSTONE ELECTRONICS CORP.

MOUNTING LAYOUT FOR TWO CLIPS
 L = .562 [14.27] FOR MINI FUSES
 L = .750 [19.04] FOR STANDARD AND LOW PROFILE FUSES

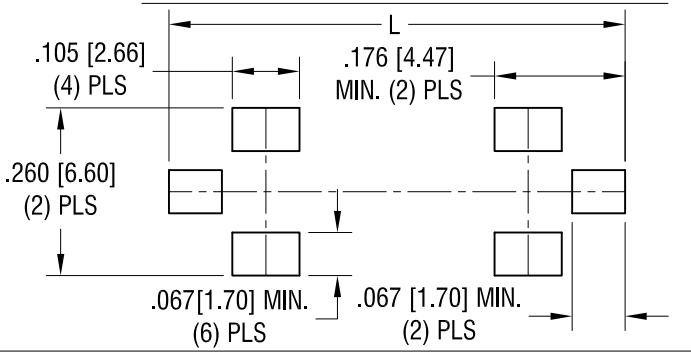

ACTUAL SIZE

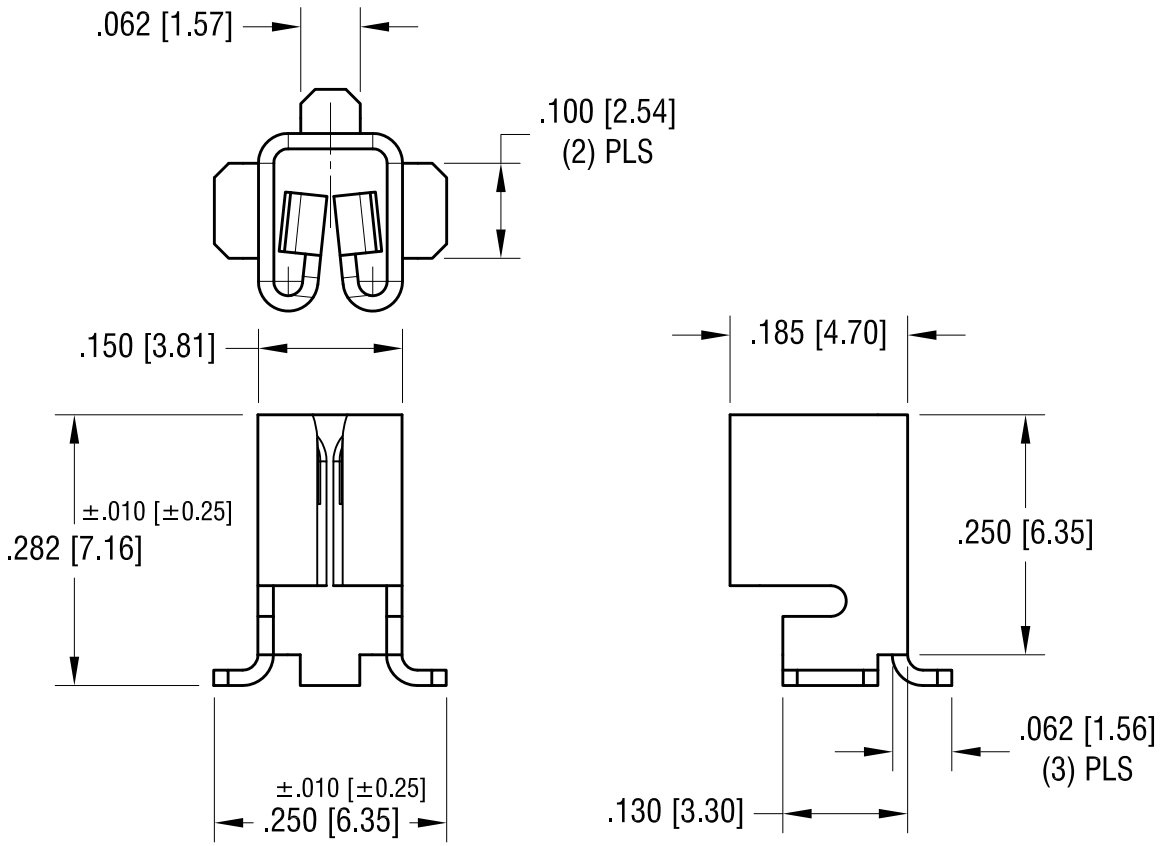

DATE	DESCRIPTION	REV.
12.15.15	CHANGE AS PER ECN 15-021	E
2.11.15	CHANGE AS PER ECN 15-021	D
4.09.14	CHANGE AS PER ECN 14-043	C
1.18.10	CHANGE AS PER ECN 10-004	B
10.06.09	CHANGE AS PER ECN 09-142	A

KEYSTONE ELECTRONICS CORP.			
www.keyelco.com • NEW HYDE PARK, NY 11040 • Tel (516) 328-7500			
PART NAME		SM UNIVERSAL AUTO FUSE CLIP	
MATERIAL		.016 [0.41] TH'K BRASS	
FINISH		DRN BY	DATE
TIN NICKEL PLATE		NT	5.06.09
		APP'D	SCALE
		RH	5X
TOLERANCES	INCH [MM]	CODE	DWG NO.
DECIMAL	± .005 [± 0.13]	C	3586
ANGULAR	± 1°		
UNLESS OTHERWISE SPECIFIED			