

This document is the property of Amphenol Corporation and is delivered on the express condition that is not to be disclosed, reproduced or used, in whole or in part, for manufacture or sale by anyone other than Amphenol Corporation without its prior consent, and that no right is granted to disclose or to use any information in this document.

The marking on this product doesn't contain environmental hazardous materials per Material Specification 55-00259 for Sony GP compliant or per directive 2011/65/EU for RoHS compliant.



ORIGINAL



REVISIONS				
SYM	ECN No.	DESCRIPTION	DATE	APPROVED
A	NE-17053	RELEASE TO PRODUCTION	03/21/2017	Arron Lin

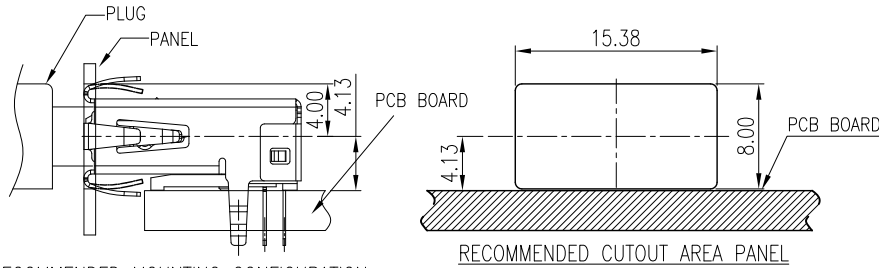

NOTES:

- MATERIAL:
 - HOUSING: THERMOPLASTIC PA9T , UL94V-0, COLOR: OPTION.
 - COVER: THERMOPLASTIC PA9T , UL94V-0, COLOR: OPTION.
 - USB 3.0 TERMINAL(5~9PIN): BRASS.
 - USB 2.0 TERMINAL(1~4PIN): PHOSPHOR BRONZE,
 - SHELL: STAINLESS STEEL
- FINISH:
 - TERMINAL:
 - CONTACT AREA: SELECTIVE GOLD PLATING ;
 - SOLDERING AREA: MATTE TIN PLATING 100 μ" THICKNESS MIN.;
 - UNDER PLATING: NICKEL PLATING 50 μ" THICKNESS MIN. OVERALL.
 - SHELL:
 - ELECTROLESS NICKEL PLATING 50 μ" THICKNESS MIN. OVERALL.
- THIS PRODUCT DOESN'T CONTAIN ENVIRONMENTAL HAZARDOUS PER DIRECTIVE 2011/65/EU FOR RoHS COMPLIANT.
- PRODUCT SPECIFICATION REFER TO : PS-7425.

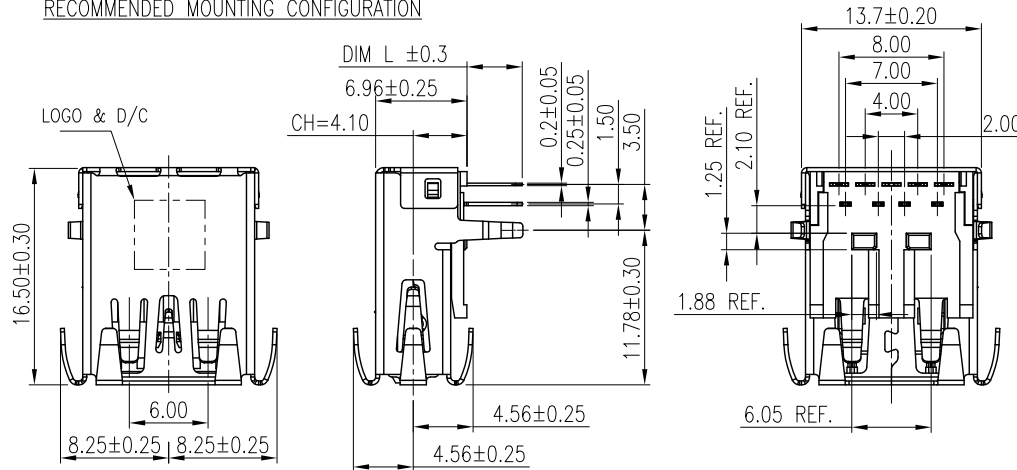

PIN #	SIGNAL NAME
1	VBUS
2	D-
3	D+
4	GND
5	SSRX-
6	SSRX+
7	GND_DRAIN
8	SSTX-
9	SSTX+
SHELL	SHIELD

PIN ASSIGNMENT

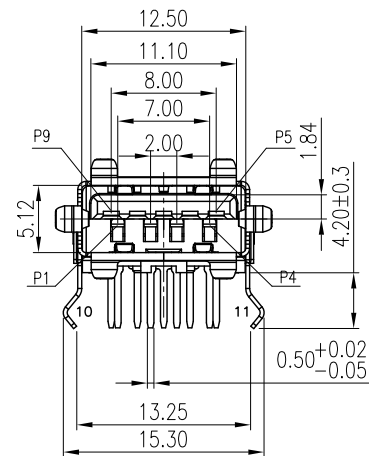
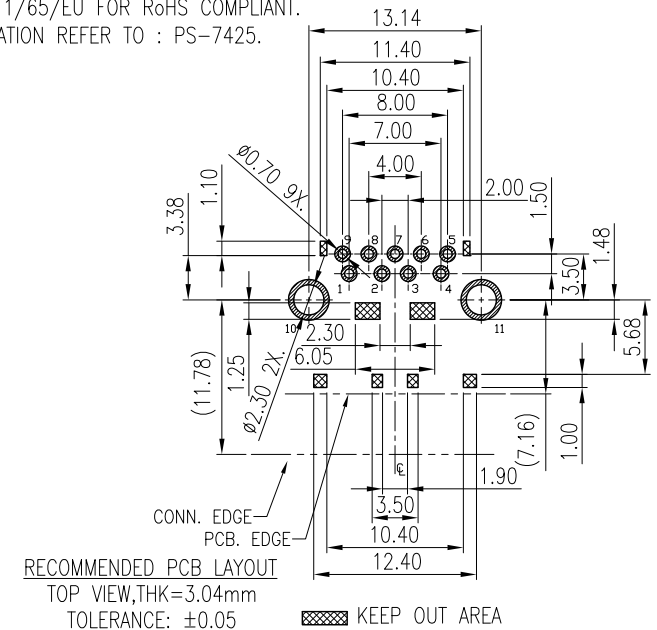

P/N: GSB311J X X X 2H4EU

CONTACT FINISH:

- FLASH GOLD
- 15u" GOLD
- 30u" GOLD

DIM L F: 4.20 MM

COLOR OPTION

- BLUE (300C)
- BLACK

TOLERANCE	APPROVALS	DATE	TITLE	UNIT	SIZE	PART No.
X. ±0.30	DRAWN Debby Hung	03/21/2017	USB 3.0 TYPE A CONN. HIGH-RISE R/A DIP TYPE (CH=4.1H)	mm	A3	Amphenol® Amphenol Corporation Amphenol Taiwan Corporation
X.X ±0.20	CHECKED Roger Tsai	03/21/2017				
X.XX ±0.10	APPROVED Arron Lin	03/21/2017				
ANGULAR ±1°	DWG TYPE CUST DWG	PROJECT CODE OTHER		SCALE NA	SHEET 1 OF 2	Part No. GSB311JXXX2H4EU
UNLESS OTHERWISE SPECIFIED						DWG No. GSB311JXXX2H4EU
						REV. A

This document is the property of Amphenol Corporation and is delivered on the express condition that is not to be disclosed, reproduced or used, in whole or in part, for manufacture or sale by anyone other than Amphenol Corporation without its prior consent, and that no right is granted to disclose or to use any information in this document.

The marking on this product doesn't contain environmental hazardous materials per Material Specification 55-00259 for Sony GP compliant or per directive 2011/65/EU for RoHS compliant.



ORIGINAL



REVISIONS				
SYM	ECN No.	DESCRIPTION	DATE	APPROVED
A	NE-17053	RELEASE TO PRODUCTION	03/21/2017	Arron Lin

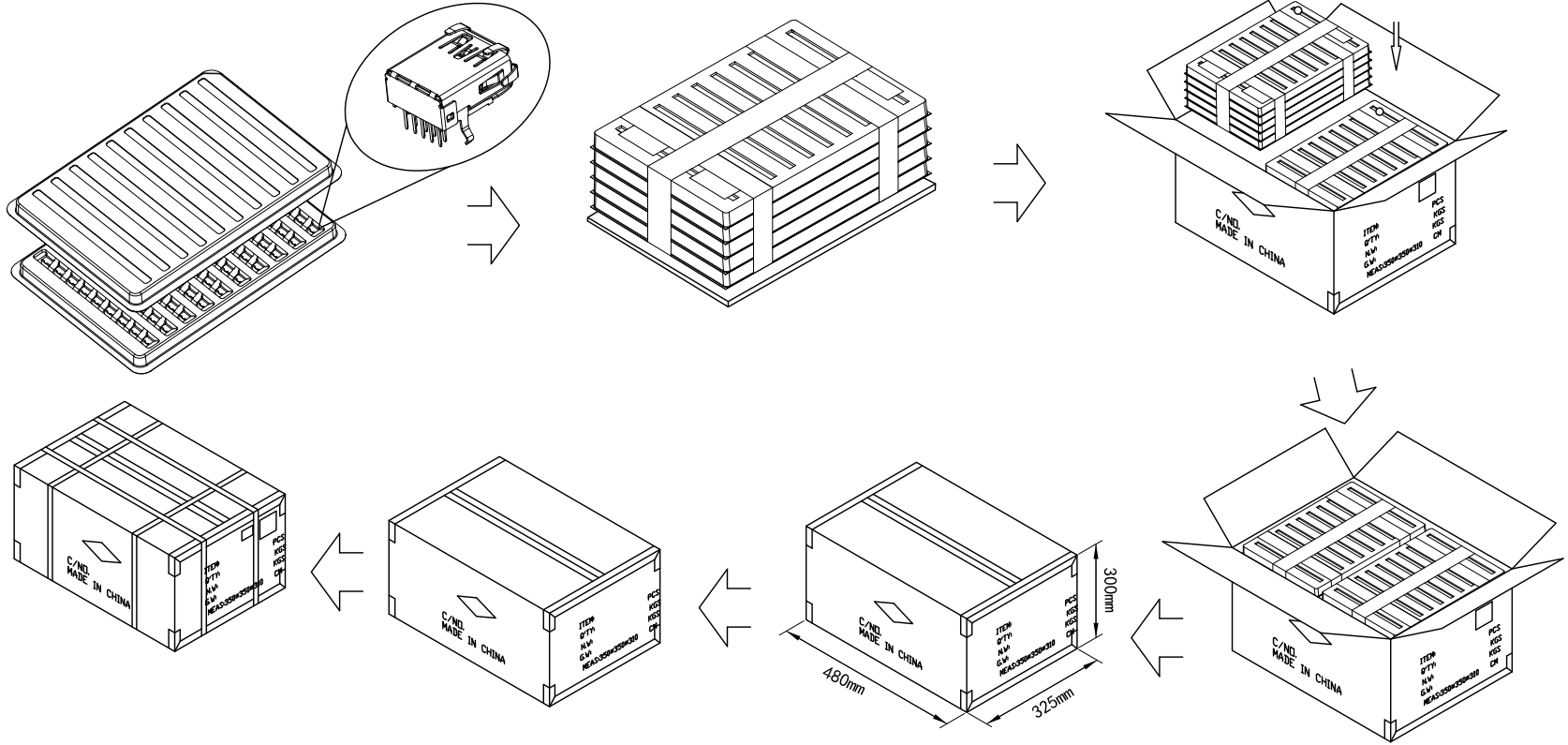

PACKAGING BY TRAY	11.0	7.1	80	36	2880	GSB311JXXX2H4EU
	G/W KG	N/W KG	PCS/ TRAY	TRAYS/ BOX	QUANTITY (PCS)	PART NUMBER

TOLERANCE	APPROVALS	DATE	TITLE	UNIT	SIZE	PART No.
X. ±0.30	DRAWN Debby Hung	03/21/2017	USB 3.0 TYPE A CONN. HIGH-RISE R/A DIP TYPE (CH=4.1H)	mm	A3	GSB311JXXX2H4EU
X.X ±0.20	CHECKED Roger Tsai	03/21/2017				
X.XX ±0.10	APPROVED Arron Lin	03/21/2017		NA	SHEET 2 OF 2	Dwg No. GSB311JXXX2H4EU REV. A
ANGULAR ±1°	DWG TYPE CUST DWG	PROJECT CODE OTHER				
UNLESS OTHERWISE SPECIFIED						

Amphenol[®]

Amphenol Corporation
Amphenol Taiwan Corporation