



ON Semiconductor®

<http://onsemi.com>

LV7109E

Bi-CMOS IC

AC Switch

Europe SCART Standard

Overview

The LV7109E is a rationalized IC of AC switch LV7108 complying with the Europe SCART standard.

Features and functions

- Video/Audio cannal-SW
- 6dB-VideoAmp
- 6/12MHz/27MHz-LowPassFilter
- 9ch VideoDriver (AV1/AV2/Line/RGB/Component)
- V-Sync. Detection
- 3ch Stereo Audio Input
- 2ch Stereo Audio Output

Specifications

Absolute Maximum Ratings at Ta = 25°C

Parameter	Symbol	Conditions	Ratings	Unit
Maximum supply voltage 1	V _{CC1} max		6.0	V
Maximum supply voltage 2	V _{CC2} max		13.0	V
Recommended supply voltage 1	V _{CC1}		5.0	V
Recommended supply voltage 2	V _{CC2}		12.0	V
Operating supply range 1	V _{CC1} opg		4.5 to 5.3	V
Operating supply range 2	V _{CC2} opg		11.1 to 12.5	V
Allowable power dissipation	Pd max	* With specified substrate	1070	mW
Operating temperature	Topr		-20 to +75	°C
Storage temperature	Tstg		-40 to +150	°C

* With specified substrate : 76.1mm × 114.3mm × 1.6mm, glass epoxy.

Stresses exceeding Maximum Ratings may damage the device. Maximum Ratings are stress ratings only. Functional operation above the Recommended Operating Conditions is not implied. Extended exposure to stresses above the Recommended Operating Conditions may affect device reliability.

LV7109E

Electrical Characteristics at Ta = 25°C, VCCV = 5.0V, VCCA = 12V

Parameter	Symbol	Input point	Output point	Test condition	Ratings			Unit
					min	typ	max	
Current dissipation 1 (5V)	I _{CC1}			Non-signal	69.7	82.0	94.3	mA
Current dissipation 2 (ALL5V)	I _{CC2}			Non-signal	11.1	13.0	15.0	mA
Current dissipation 3 (12V)	I _{CC3}			Non-signal	7.7	9.0	10.4	mA
Video CANAL SW part								
Output voltage 1	VDCC			AV1, AV2-OUT (Sync tip)	0.5	0.7	0.9	V
Voltage gain	VGC			V _{IN} = 1Vp-p, f = 100kHz, AV1, AV2-OUT	5.5	6.0	6.5	dB
Frequency characteristics 1	VFC1	17	12	V _{IN} = 1Vp-p, f = 10MHz/100kHz (P17, P19: Through)	-1.0	0.0	+1.0	dB
Frequency characteristics 2	VFC2	38	12	V _{IN} = 1Vp-p, f = 6MHz/100kHz (P38, P40: 6MHz-LPF)	-1.5	0.0	+1.5	dB
DG Differential gain	DGC	40	14	V _{IN} = Video : 1Vp-p	-1	0	+1	%
DP Differential phase	DPC	19	14	V _{IN} = Video : 1Vp-p	-1.5	0	+1.5	°C
Cross talk between channel	CTC	38	14	Selected input = GND Non-selected input = 1Vp-p, f = 4.43MHz		-60	-50	dB
Picture S/N	VSNC	40	14	V _{IN} = Video (50%White)		-70	-65	dB
Maximum output level 1	V _O MAXC1	17	12	Output level (Trough output) whose linearity exceeds 1%	2.8	3.0		Vp-p
		19	14	V _{IN} = Linearity (lamp) signal Output level at linearity 1%				
Maximum output level 2	V _O MAXC2	38	12	Output level (ENC output) whose linearity exceeds 1%	2.6	2.7		Vp-p
		40	14	V _{IN} = Linearity (lamp) signal Output level at linearity 1%				
Video INPUT SW part								
Output voltage 1	VDCI1	17, 19, 21	35	Composite (Sync-Tip)	0.8	1.0	1.2	V
Output voltage 2	VDCI2	17, 19, 21	35	Y (Sync-Tip)	0.8	1.0	1.2	V
Output voltage 3	VDCI3	3	33	Chroma (Center)	1.8	2.1	2.4	V
Voltage gain 1	VGI1	17, 19, 21	33	V _{IN} = 1Vp-p, f = 100kHz, load = 10kΩ	-0.5	0.0	+0.5	dB
		3	35					
Frequency characteristics	VFI	17, 19, 21	33	V _{IN} = 1Vp-p, f = 10MHz/100kHz	-1.0	0.0	+1.0	dB
		3	35					
DG Differential Gain	DGSW	17, 19, 21	35	V _{IN} = Video :1Vp-p	-1	0	+1	%
DP Differential Phase	DPSW	17, 19, 21	35	V _{IN} = Video :1Vp-p	-1.5	0	+1.5	°C
Cross talk between channel	CTAD	17, 19, 21	33	Selected input = GND		-60	-50	dB
		3	35	Non-selected input = 1Vp-p, f = 4.43MHz				
Picture S/N	VSNC	17, 19, 21	35	V _{IN} = Video (50%White)		-66	-60	dB
Maximum output level	V _O MAXSW	17, 19, 21	35	Output level (ENC output) whose linearity exceeds 1%	1.8	2.0		Vp-p
				V _{IN} = Linearity (lamp) signal Output level at linearity 1%				
Video Driver part								
Output voltage 1	VDCD1	64, 46	6	RGB (Pedestal)	0.6	0.8	1.0	V
		1, 44	8					
		3, 42	10					
Output voltage 2	VDCD2	40	16	CVBS (Sync tip)	0.5	0.7	0.9	V
			27	Y (Sync tip)				
Output voltage 3	VDCD3	3	10	C, Pr, Pb (Center)	1.7	2.0	2.3	V
		46	23					
		42	25					
Output voltage 4	VDCD4	40	27	Y (Sync tip)	0.8	1.0	1.2	V
Voltage gain 1	VGD1	64, 46	6, 23	For V _{IN} = 1Vp-p and f = 100kHz Line	5.5	6.0	6.5	dB
		1, 44	8, 27	output only: 2 drives, Other outputs: 1drive				
		3, 42	10, 25					
		40, 38	12, 14, 16					

Continued on next page.

LV7109E

Continued from preceding page.

Parameter	Symbol	Input point	Output point	Test condition	Ratings			Unit
					min	typ	max	
Frequency characteristics 1	VFD1	46, 44, 42 40, 38	6, 8, 10 23, 27, 25 12, 14 16	$V_{IN} = 1V_{p-p}$, $f = 6MHz/100kHz$ when 6MHzLPF is selected	-1.5	0.0	+1.5	dB
Frequency characteristics 2	VFD2	46 44 42	6 8 10	$f = 27MHz/100kHz$ when 6MHzLPF is selected		-35	-25	dB
Frequency characteristics 3	VFD3	46 44 42	23 27 25	$f = 12MHz/100kHz$ when 12MHzLPF is selected	-1.5	0.0	+1.5	dB
Frequency characteristics 4	VFD4	46 44 42	23 27 25	$f = 54MHz/100kHz$ when 12MHzLPF is selected		-40	-30	dB
Frequency characteristics 5	VFD5	46 42	23 25	$f = 13.5MHz/100kHz$ when 13.5MHzLPF is selected	-1.5	0.0	+1.5	dB
Frequency characteristics 6	VFD6	46 42	23 25	$f = 74MHz/100kHz$ when 13.5MHzLPF is selected		-40	-30	dB
Frequency characteristics 7	VFD7	44	27	$f = 25MHz/100kHz$ when 27MHzLPF is selected	-1.5	0.0	+1.5	dB
Frequency characteristics 8	VFD8	44	27	$f = 74MHz/100kHz$ when 27MHzLPF is selected		-40	-30	dB
Group delay 1	VGDD1	46, 44, 42 40, 38	6, 8, 10 23, 27, 25 12, 14 16	$f = 6MHz/100kHz$ when 6MHzLPF is selected		20	35	ns
Group delay 2	VGDD2	46 44 42	23 27 25	$f = 12MHz/100kHz$ when 12MHzLPF is selected		14	25	ns
Group delay 3	VGDD3	46 42	23 25	$f = 27MHz/100kHz$ when 13.5MHzLPF is selected		10	18	ns
Group delay 4	VGDD4	44	27	$f = 27MHz/100kHz$ when 27MHzLPF is selected		10	18	ns
Mute attenuation	VMUD		ALL	$V_{IN} = 1V_{p-p}$, $f = 4.43MHz$		-60	-50	dB
DG Differential gain	DG1		ALL	$V_{IN} = \text{Video} : 1V_{p-p}$	-1	0	+1	%
DP Differential phase	DP1		ALL	$V_{IN} = \text{Video} : 1V_{p-p}$	-1.5	0	+1.5	°C
Cross talk between channel	CTD		ALL	$V_{IN} = 1V_{p-p}$, $f = 4.43MHz$ Driver output terminated with 75Ω		-60	-50	dB
Picture S/N	VSND		ALL	$V_{IN} = \text{Video} (50\% \text{White})$		-70	-65	dB
Maximum output level 1	$V_{O}MAXD1$	64, 46 1, 44 3, 42	6 8 10	Output level (RGB) whose linearity exceeds 1% $V_{IN} = \text{Linearity (lamp) signal}$ Output level at linearity 1%	2.5	2.7		Vp-p
Maximum output level 2	$V_{O}MAXD2$	40	16 27	Output level (brightness, CVBS) whose linearity exceeds 1% $V_{IN} = \text{Linearity (lamp) signal}$ Output level at linearity 1%	2.6	2.8		Vp-p
Maximum output level 3	$V_{O}MAXD3$	46 42	23 25	Output level (color difference) whose linearity exceeds 1% $V_{IN} = \sin 10kHz$ Output level at linearity 1%	2.0	2.5		Vp-p
Sync-SEP part								
V.SYNC output High voltage	VVSH	17, 19, 21	34		4.3	4.7	5.0	V
V.SYNC output Low voltage	VVSL	17, 19, 21	34		0.0	0.3	0.6	V
V.SYNC output delay time	TDVS	17, 19, 21	34	Note 2)	7	15	25	μs
V.SYNC output pulse width	TWVS	17, 19, 21	34	$V_{IN} = \text{PAL Video} : 1V_{p-p}$ Note 2)	125	155	185	μs

Note 2) When pin 10 is open

Continued on next page.

LV7109E

Continued from preceding page.

Parameter	Symbol	Input point	Output point	Test condition	Ratings			Unit
					min	typ	max	
Audio canal switches part								
Maximum output level	V _O MAXC	R-Ch. 49, 50, 51	R-Ch. 58, 61	AV1, AV2-OUT (L, R) Output level at f = 1kHz, THD = 1% BW = 400 to 30kHz	2.2	2.5		Vrms
Channel balance	CVSW			V _{IN} = 2Vrms, f = 1kHz Lch Gain-Rch Gain	-1.5	0.0	+1.5	dB
Total harmonic distortion	THDAC			V _{IN} = 2Vrms, f = 1kHz, BW = 400 to 30kHz		0.003	0.01	%
Output noise voltage	VNAC			Rg = 0Ω, BW = JIS-A		-100	-80	dBV
Mute attenuation	VMUAC	L-Ch. 54, 55, 56	L-Ch. 59, 62	V _{IN} = 2Vrms, f = 1kHz, BW = JIS-A 20log (V _{OUT} /V _{IN})		-90	-75	dB
Input impedance	Z _{IN}				80	100	120	kΩ
Cross talk between channel and selectors	CTSW			V _{IN} = 2Vrms, f = 1kHz Rg = 0Ω, BW = JIS-A		-110	-80	dB
Output off set voltage	V _O FSET			Off set voltage at the time of changeover SW.	-20	0	+20	mV
External control part								
I ² C-BUS High level input voltage	V _I H	36 37			2.5		V _{CC} ⁵	V
I ² C-BUS Low level input voltage	V _I L	36 37			GND		0.8	V
FSS output H voltage	VHFSS		7	Serial control select FSS OUT H, load = 10kΩ external output resistor 470 recommended	10.6	11.1	11.6	V
FSS output M voltage	VMFSS		7	Serial control select FSS OUT M, load = 10kΩ external output resistor 470 recommended	5.5	6.3	7.0	V
FSS output L voltage	VLSS		7	Serial control select FSS OUT, load = 10kΩ	0.0	0.1	0.5	V
FSS rising time	TFSSLH		7				1.0	ms
FB output H voltage	VHFB		18	Serial control select FB OUT H, load = 150Ω	3.0	4.0	5.0	V
FB output L voltage	VLFB		18	Serial control select FB OUT L, load = 150Ω	0.0	0.2	0.4	V
FB external control L range	VLFBIN	20	18	Pin 20 input voltage range at which the pin 18 output becomes "L".	0.0		0.5	V
FB external control H range	VHFBIN	20	18	Pin 20 input voltage range at which the pin 18 output becomes "H".	1.0		3.0	V
External control output H voltage	V _{EXT} H		26	2kΩ load for data 1	4.0	4.5	5.0	V
External control output L voltage	V _{EXT} L		26	2kΩ load for data 0	0.0	0.3	1.0	V
Internal reference regulator								
REG2.5V	VREG25		2 31		2.3	2.5	2.7	V
REG9.0V	VREG90		52 57		8.7	9.0	9.3	V
VRE4.5	VREG45		48		4.3	4.5	4.7	V

LV7109E

Video Power Supply Block Diagram

The thick line indicates the circuit operative in the power save mode.

Applied power to VCC5V_All, VCC5V_SW and VCC_LOGIC only in the power save mode.

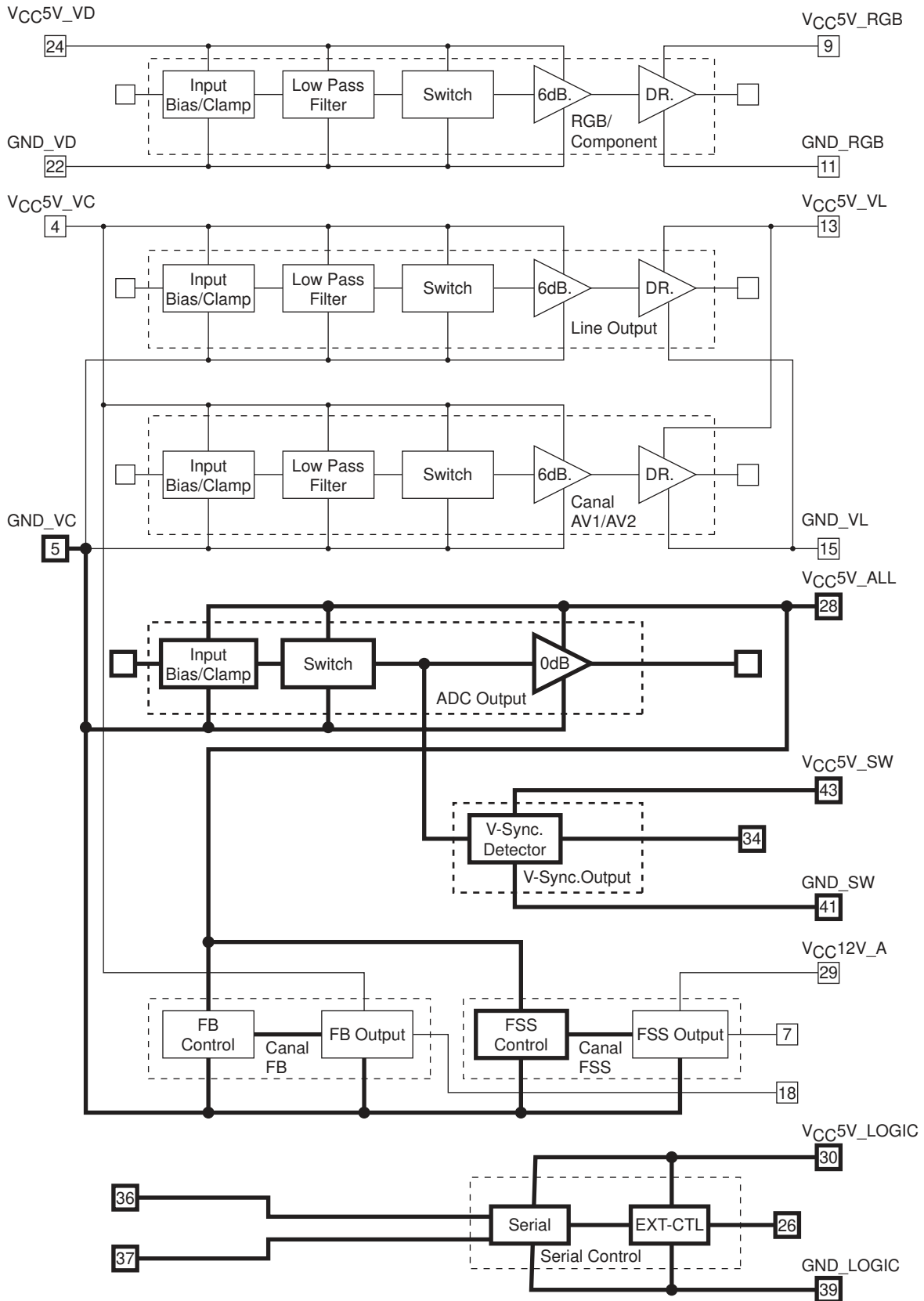

Block Diagram

- ⊗ LV7109 PIN (for Power Save)
- ⊗ LV7109 PIN (always Power ON)
- ⊗ SCART PIN

Marks of switches are assigned alphabetically from LSB.
 ex.) assign 3bit register
 a=000, b=001, c=010, d=011, e=100, f=101

Pin List Bold parts are for Always Power ON

1	AV2_G_IN	33	C_ADC
2	REG2.5V	34	V-Sync_OUT
3	AV2_R/C_IN	35	Y/V_ADC
4	GND_VC	36	SDA_IN
5	VCC5V_VC	37	SCL_IN
6	AV1_B_OUT	38	ENC C_IN
7	AV1_FSS_OUT	39	GND_LOGIC
8	AV1_G_OUT	40	ENC Y_IN
9	VCC5V_RGB	41	GND_V_SW
10	AV1_R/C_OUT	42	ENC R_IN
11	GND_RGB	43	VCC5V_SW
12	AV2_V_OUT	44	ENC G_IN
13	VCC5V_VL	45	GND_REF
14	AV1_VY_OUT	46	ENC B_IN
15	GND_VL	47	Audio_Mute_Filter
16	V_OUT(Line)	48	REF4.5V
17	AV1_V_IN	49	A-DAC_R_IN
18	AV1_FB_OUT	50	AV2_R_IN
19	AV2_VY_IN	51	AV1_R_IN
20	AV2_FB_IN	52	REGV_AR
21	AV3_V_IN	53	GND_REG
22	GND_VD	54	A-DAC_L_IN
23	PB_OUT(Component)	55	AV2_L_IN
24	VCC5V_VD	56	AV1_L_IN
25	PR_OUT(Component)	57	REG9V_AL
26	EXT_CTL1	58	AV2_R_OUT
27	PY_OUT(Component)	59	AV2_L_OUT
28	VCC5V_ALL	60	GND_AR
29	VCC12V_A	61	AV1_R_OUT
30	VCC5V_LOGIC	62	AV1_L_OUT
31	REG2.5V_ALL	63	GND_AL
32	Sync_Sep_Filter	64	AV2_B_IN

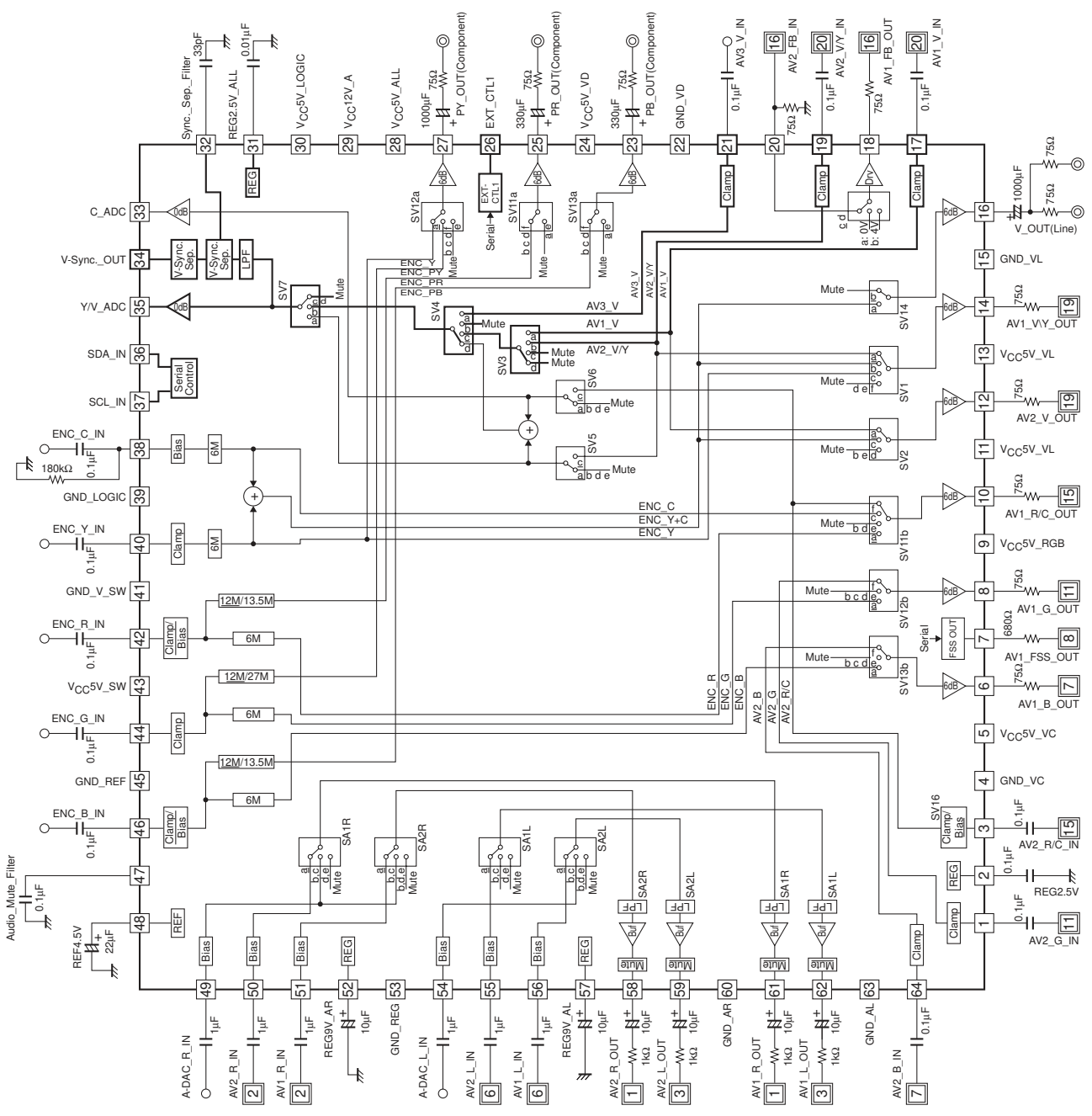

LV7109E

LV7109E Serial Control Table

* indicates initial.

ADDRESS	8	7	6	5	4	3	2	1	Symbol	Input	Output	Remarks	
Group 1 0000 0001 VIDEO CANAL-SW VIDEO	SV1	0	0	0	0	0	0	0	a	P19	AV2_V/Y_IN	P10: AV1_R/C_OUT	*
		0	0	0	1	0	0	0	b	-	ENC_Y+C_MIX		
		0	1	0	0	0	0	0	C	P40	ENC_Y		
		0	1	1	0	0	0	0	d	-	MUTE		
		1	0	0	0	0	0	0	e	-	MUTE		
		1	0	0	1	0	0	0	f	-	MUTE		
	1	1	0	0	0	0	0	-	-	PROHIBIT			
	SV2	0	0	0	0	0	0	0	a	P17	AV1_V_IN	P12: AV2_V_OUT	*
		0	0	1	0	0	0	0	b	-	MUTE		
		0	1	0	0	0	0	0	c	-	ENC_Y+C_MIX		
		0	1	1	0	0	0	0	d	-	MUTE		
		1	0	0	0	0	0	0	e	-	MUTE		
	1	0	1	0	0	0	0	-	-	PROHIBIT			
	SV3	0	0	0	0	0	0	0	a	P17	AV1_V_IN	SV4	
		0	1	0	0	0	0	0	b	P19	AV2_V/Y_IN		*
1		0	0	0	0	0	0	c	-	N/A			
1		1	0	0	0	0	0	d	-	N/A			

ADDRESS	8	7	6	5	4	3	2	1	Symbol	Input	Output	Remarks		
Group 2 0000 0010 VIDEO INPUT-SW	SV4	0	0	0	0	0	0	0	a	P21	AV3_V_IN	SV7		
		0	1	0	0	0	0	0	b	-	N/A			
		1	0	0	0	0	0	0	C	According to SV3 control			*	
		1	1	0	0	0	0	0	d	-	SV5/6 MIX			
	SV2	0	0	0	0	0	0	0	a	-	MUTE	MUTE	Y+C MIX SV7 P33: C_ADC	
		0	0	1	0	0	0	0	b	-	MUTE	MUTE		
		0	1	0	0	0	0	0	c	P19	AV2_V/Y_IN	AV2_R/C_IN		
		0	1	1	0	0	0	0	d	-	MUTE	MUTE		
		1	0	0	0	0	0	0	e	-	MUTE	MUTE		*
	1	0	1	0	0	0	0	-	-	PROHIBIT	PROHIBIT			
	SV3	0	0	0	0	0	0	0	a	SV5	Y	P35: Y/V_ADC		
		0	1	0	0	0	0	0	b	SV4	Composit Video			
		1	0	0	0	0	0	0	c	-	MUTE		*	
	SV16 Note 1)	0	0	0	0	0	0	0	-	-	THROUGH		*	
		1	0	0	0	0	0	0	-	-	CLAMP input			

ADDRESS	8	7	6	5	4	3	2	1	Symbol	Input	Output	Remarks				
Group 3 0000 0011 VIDEO OTHER-1	12/27MHz LPF SW	0	0	0	0	0	0	0	-				x = 12MHz			
		1	0	0	0	0	0	0	-				x = 27MHz			
	RGB output	0	0	0	0	0	0	0	-	According to G3D3-5 control						
		1	0	0	0	0	0	0	-	Switch of SV11b-13b set to "f"			f: AV2_RGB (EXTERNAL)			
	SV11a SV12a SV13a	0	0	0	0	0	0	0	a	-	MUTE	P40	ENC_Y_IN	-	MUTE	a: ENC_Y
		0	0	1	0	0	0	0	b	P42	ENC_R_IN	P44	ENC_G_IN	P46	ENC_B_IN	b: Component (x MLPF)
		0	1	0	0	0	0	0	c	P42	ENC_R_IN	P44	ENC_G_IN	P46	ENC_B_IN	c: Component (x MLPF)
		0	1	1	0	0	0	0	d	P42	ENC_R_IN	P44	ENC_G_IN	P46	ENC_B_IN	d: Component (x MLPF)
		1	0	0	0	0	0	0	e	-	MUTE	-	MUTE	-	MUTE	e: mute
		1	0	1	0	0	0	0	f	P42	ENC_R_IN	P44	ENC_G_IN	P46	ENC_B_IN	f: Component (x MLPF)
		1	1	0	0	0	0	0	-	-	PROHIBIT	-	PROHIBIT	-	PROHIBIT	
	SV11b SV12b SV13b * effective at G3D2 = "0"	0	0	0	0	0	0	0	a	P42	ENC_R_IN	P44	ENC_G_IN	P46	ENC_B_IN	a: ENC_RGB (6MLPF)
		0	0	1	0	0	0	0	b	-	MUTE	-	MUTE	-	MUTE	b: mute
		0	1	0	0	0	0	0	c	P38	ENC_C_IN	-	MUTE	-	MUTE	c: ENC_C
		0	1	1	0	0	0	0	d	-	MUTE	-	MUTE	-	MUTE	d: mute
		1	0	0	0	0	0	0	e	-	MUTE	-	MUTE	-	MUTE	e: mute
		1	0	1	0	0	0	0	f	P3	AV2_R/C_IN	P1	AV2_G_IN	P64	AV2_B_IN	f: AV2_RGB (EXTERNAL)
		1	1	0	0	0	0	0	-	-	PROHIBIT	-	PROHIBIT	-	PROHIBIT	
	SV14	0	0	0	0	0	0	0	a	-	ENC_Y+C					
		1	0	0	0	0	0	0	b	-	MUTE				*	
	N/A	0	0	0	0	0	0	0	a	-	-	-	-	-	*	
		1	0	0	0	0	0	0	b	-	-	-	-	-	*	
	SV16 Note 1)	0	0	0	0	0	0	0	-	-	THROUGH				*	
		1	0	0	0	0	0	0	-	-	BIAS input				*	

Note 1) G2D8/G3D8 = "11" is prohibited. Follow the AV2 (16) FB_IN (Pin32) control in case of THROUGH.

- AV2_16pin SV16
- H a : Clamp input (RGB)
- L b : Bias input (Y+C)

LV7109E

* indicates initial.

ADDRESS	8	7	6	5	4	3	2	1	Symbol	Input				Output	Remarks
Group 4 0000 0100 VIDEO & AUDIO OTHER-1	N/A							0	a	-	N/A	-	N/A		*
								1	b	-	N/A	-	N/A		*
	N/A							0	a	-	N/A	-	N/A		*
								1	b	-	N/A	-	N/A		*
	FB AV1 (16) Note 2)				0					a	-	0V		P18: AV1_FB_OUT	
					0	1				b	-	5V			*
	FSS AV1 (8)				1	0				c	P20	THROUGH		P7: AV1_FSS_OUT	*
					1	1				d	P20	THROUGH			*
				0	0					-	-	LOW (0.5V)			*
	N/A				0	1				-	-	MID (6.0V)		*	
					1	0				-	-	HIGH (11.0V)		*	
					1	1				-	-	HIGH (11.0V)		*	
	N/A				0					-	-	-		*	
					1					-	-	-		*	
A-MUTE				0					-	-	THROUGH				
				1					-	-	MUTE		P58,59,61,62 output MUTE	*	

Note 2) Same polarity as the AV2 (16) FB_IN (Pin20) control in case of THROUGH.

ADDRESS	8	7	6	5	4	3	2	1	Symbol	Input				Output	Remarks	
Group 5 0000 0101 AUDIO CANAL-SW	SA1L/R						0	0	a	P55	AV2_L_IN	P50	AV2_R_IN	P62: AV1_L_OUT P61: AV1_R_OUT	*	
							0	0	1	b	P54	A-DAC_L_IN	P49		A-DAC_R_IN	
							0	1	0	c	P54	A-DAC_L_IN	P49		A-DAC_R_IN	
							0	1	1	d	-	MUTE	-		MUTE	
							1	0	0	e	-	MUTE	-		MUTE	
							and after	1	0	1	f	-	PROHIBIT		-	PROHIBIT
	SA2L/R			0	0	0				a	P56	AV1_L_IN	P51	AV1_R_IN	P59: AV2_L_OUT P58: AV2_R_OUT	*
				0	0	1				b	-	MUTE	-	MUTE		
				0	1	0				c	P54	A-DAC_L_IN	P49	A-DAC_R_IN		
				0	1	1				d	-	MUTE	-	MUTE		
			1	0	0				e	-	MUTE	-	MUTE			
N/A			1	0	1				and after	-	PROHIBIT	-	PROHIBIT			
			0	0					a	-	N/A	-	N/A			
			0	1					b	-	N/A	-	N/A			
			1	0					c	-	N/A	-	N/A	*		
		1	1					d	-	N/A	-	N/A				

ADDRESS	8	7	6	5	4	3	2	1	Symbol	Input				Output	Remarks	
Group 6 0000 0110	N/A							0	0	a	-	N/A	-	N/A		
								0	0	1	b	-	N/A	-	N/A	*
								0	1	0	c	-	N/A	-	N/A	
								0	1	1	d	-	N/A	-	N/A	
								1	0	0	e	-	N/A	-	N/A	
							and after	1	0	1	-	PROHIBIT	-	PROHIBIT		
	N/A				0					a	-	N/A				
					1					b	-	N/A			*	
	N/A			0	0					a	-	N/A				
				0	1					b	-	N/A			*	
			1	0					c	-	N/A					
		1	1						-	PROHIBIT						
N/A			0	0					a	-	N/A					
			0	1					b	-	N/A			*		
			1	0					c	-	N/A					
			1	1					-	-	PROHIBIT					

ADDRESS	8	7	6	5	4	3	2	1	Symbol	Input				Output	Remarks		
Group 7 0000 0111	N/A			0	0	0	0	0		-	-	N/A					
				0	0	1	1	0	0		-	-	N/A				
				1	1	1	1	1	1		-	-	N/A		*		
				Other than above							-	-	PROHIBIT				
	EXT-CTL1			0							-	-	L	P26: EXT_CTL1	General purpose OUT1		
				1							-	-	H				
	Changeover of VIDEO input BIAS/CLAMP		-	-	-	-	-	-	-		P42	ENC_R_IN	P44	ENC_G_IN	P46	ENC_B_IN	Input changeover
			0								-	BIAS input		CLAMP input		BIAS input	Component
			1								-	CLAMP input		CLAMP input		CLAMP input	RGB

LV7109E

* indicates initial.

ADDRESS	8	7	6	5	4	3	2	1	Symbol	Input	Output	Remarks
Group 8 0000 1000	N/A	0	0	0	0	0	0	0	-	-	N/A	
		0	0	1	1	0	0	0	-	-	N/A	
		1	1	1	1	1	1	1	-	-	N/A	*
		Other than above							-	-	PROHIBIT	
N/A	N/A	0							-	-	N/A	*
		1							-	-	N/A	*
		0							-	-	N/A	*
		1							-	-	N/A	*

Cautions for Use

1. Drive capacity of video driver

Line outputs can drive two systems through capacitive coupling.

Component outputs can drive one systems through capacitive coupling.

Scart output can drive one system only through DC coupling.

2. Audio Mute

This IC incorporates a mute transistor to reduce the POP noise of audio output when power is turned ON/OFF.

Mute control can be made by serial control.

3. Resistor to limit the Audio input

When the large signal is input in the input pin with power OFF, cross-talk between input and output occurs through the protective diode and parasitic elements. Because of the structure of LSI, such cross-talk is difficult to avoid.

If cross-talk at a time of power OFF presents a problem, the cross-talk amount can be reduced by inserting the limiting resistor in the input.

In this case, the input signal level changes depending on the resistance value. Determine the constant while taking both the cross-talk amount and input level into account.

4. Pin treatment when external control is not to be used

When external control pins (Pins 26) are not used, pull-down to GND is recommended.

5. Audio 9V_REG pin external capacitance

Use the Audio 9V_REG pins (pins 52 and 57) external capacitance of 10 μ F or more and with the equivalent series resistance component of 7 Ω or less.

6. Power application and disconnection sequences

The recommended power application sequence to this IC is V_{CC}ALL5V (Pin28) → V_{CC}5V (Pins 5, 9, 13, 24, 30 and 43), V_{CC}12V (Pin29).

(No particular order is established between V_{CC}5V and V_{CC}12V.) It is recommended to reverse the above sequence when power supply is turned OFF.

Serial Control Specification

1. Slave address

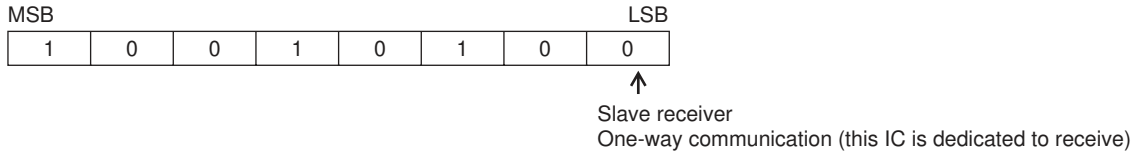

2. DATA TRANSFER MANUAL : [1] is High level. [0] is Low level.

I²C-BUS control system is adopted in SW LSI. SW LSI is controlled by SCL (Serial Clock) and SDA (Serial Data) At first, please set up the START condition^{*1} by these two terminals (SCL and SDA). And next, please input the 8bits data, which should be synchronized with SCL into SDA terminal. Still more, please give priority to high rank bit at data transfer order (MSB→LSB). The 9th bit is called as ACK (Acknowledge), SW LSI sends [0] to the SDA terminal during SCL [1] period. So, please open the port of microprocessor during this period. LV7107M adopt auto-increment, so you input only first group-address and you can transfer data in order. As thus the Data transfer Stop condition^{*2} is finished.

^{*1} SDA rise up during SCI is [1]

^{*2} SDA fall down during SCL is [1]

3. TRANSFER DATA FORMAT

The transfer data is composed by START condition, Slave address, Group address^{*4}, data, and STOP condition. After setting up the START condition, please transfer the Slave Address (regulated as “1001000” in SW LSI). Group and next control data (Please see the Fig.1)

Slave Address is composed by 7bits, and this bit 8th bit^{*5} should be set as [0].

The both of Group address and control data are composed by 8bits, and the one control action is defined with combination of these two data. And if you want to control 2 or more groups at the same mode, you can realize it by sending some control data together.

The data makes meaning with all bits, so you cannot stop the sending until all data transfer is over.

But LV7107M adopt auto-increment, for example you can stop to transfer STOP condition after group 2 data.

If you want to stop transfer action, please transfer the STOP condition without fail.

^{*4} There are 8 control groups.

^{*5} This 8th bit called as R/W bit, and this bit shows the data transmission direction. [0] means send mode (accept mode with SW LSI) and [1] means accept mode (send mode with SW LSI) fundamentally. But SW LSI is not equipped with such a data out function, please keep this bit as [0].

Fig. 1 DATA STRUCTURE

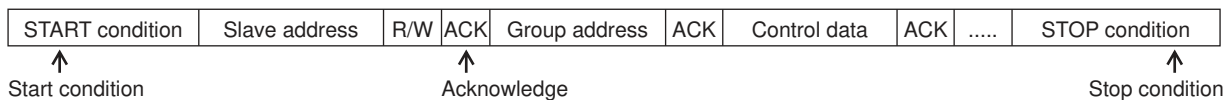

LV7109E

4. INITIALIZE AND OTHERS

SW LSI is initialized as the following mode for circuit protection. Please see “SERIAL CONTROL TABLE”.

Characteristics of the SDA and SCL I/O stages for SW LSI

Parameter	Symbol	Min	Max	Unit
LOW level input voltage	V_{IL}	0	0.8	V
HIGH level input voltage	V_{IH}	3.0	5.0	V
LOW level output current	I_{OL}		3.0	mA
SCL clock frequency	f_{SCL}		400	kHz
Set-up time for a repeated START condition	$t_{SU : STA}$	0.6		μs
Hold time START condition. After this period, the first clock pulse is generated.	$t_{HD : STA}$	0.6		μs
LOW period of the SCL clock	t_{LOW}	1.3		μs
Rise time of both SDA and SDL signals	t_R	0	0.3	μs
HIGH period of the SCL clock	t_{HIGH}	0.6		μs
Fall time of both SDA and SDL signals	t_F	0	0.3	μs
Data hold time:	$t_{HD : DAT}$	0	0.9	μs
Data set-up time	$t_{SU : DAT}$	100		ns
Set-up time for STOP condition	$t_{SU : STO}$	0.6		μs
BUS fredd time between a STOP and START condition	t_{BUF}	1.3		μs

Fig.2 Definition of timing.

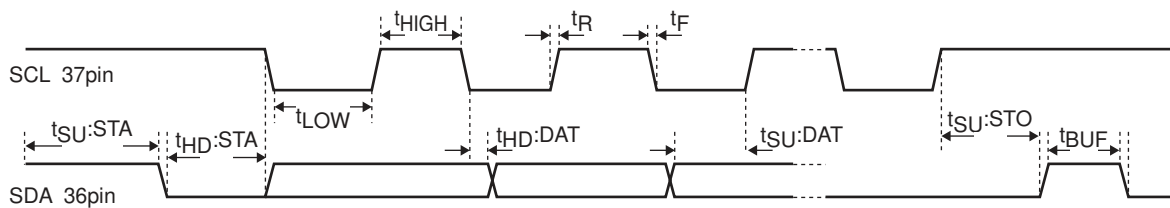

LV7109E

Pin Function

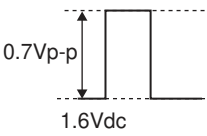
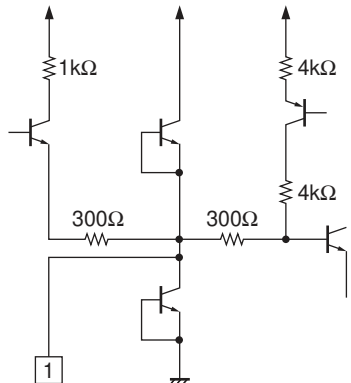
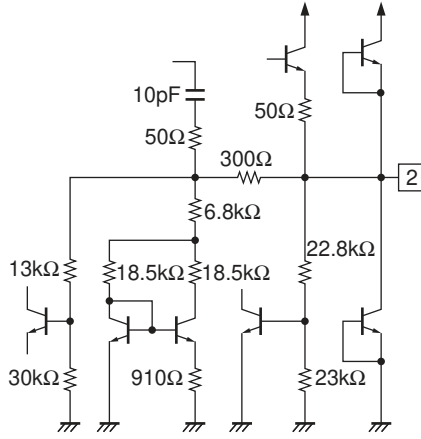
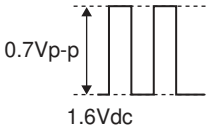
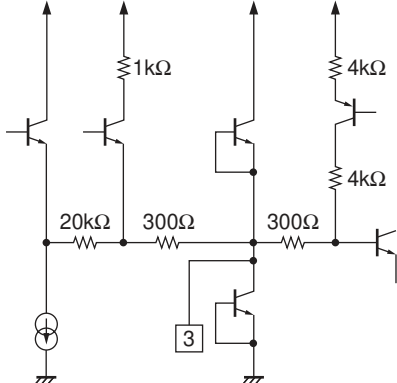
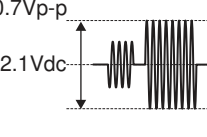
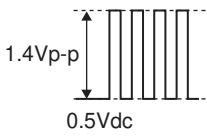
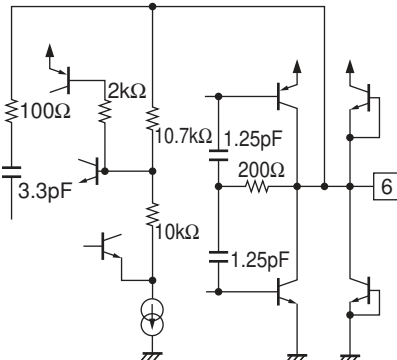
Pin No.	Pin name	DC voltage	Signal wave form	Input/Output form	Note
P1	AV2_G_IN	1.6Vdc +Green			
P2	REG2.5V	2.5Vdc	DC		
P3	AV2_R/C_IN	1.6Vdc +Red			
		2.1Vdc +Chroma			
P4	GND_VC				
P5	V _{CC} 5V_VC				
P6	AV1_B_OUT	0.5V +Blue			

Continued on next page.

LV7109E

Continued from preceding page.

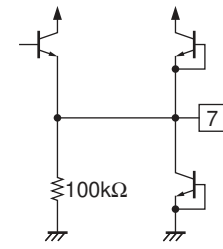
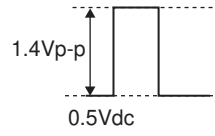
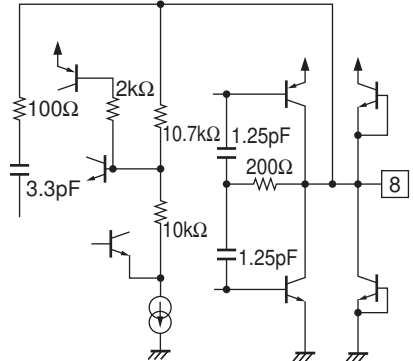
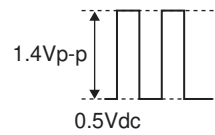
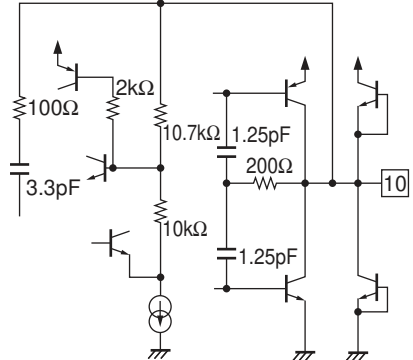
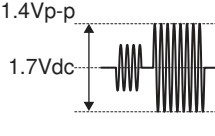
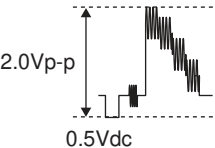
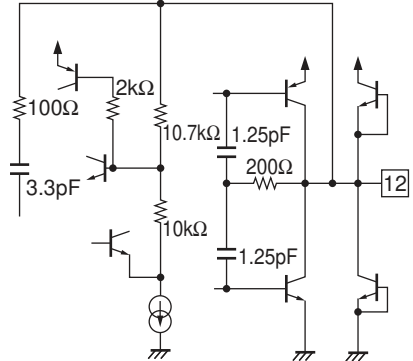
Pin No.	Pin name	DC voltage	Signal wave form	Input/Output form	Note
P7	AV1_FSS_OUT	Low : 0.5V Mid : 6.0V High : 11.1V	DC		
P8	AV1_G_OUT	0.5Vdc +Green			
P9	V _{CC_RGB}				
P10	AV1_R/C_OUT	0.5Vdc +Red			
		1.7Vdc +Chroma			
P11	GND_RGB				
P12	AV2_V_OUT	0.5Vdc +Video			
P13	V _{CC5V_VL}				

Continued on next page.

LV7109E

Continued from preceding page.

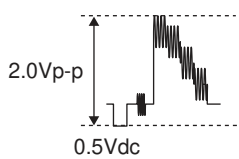
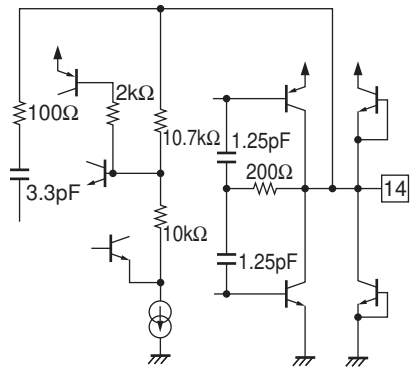
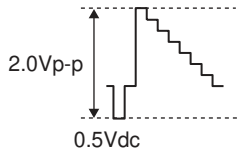
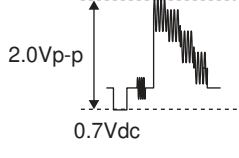
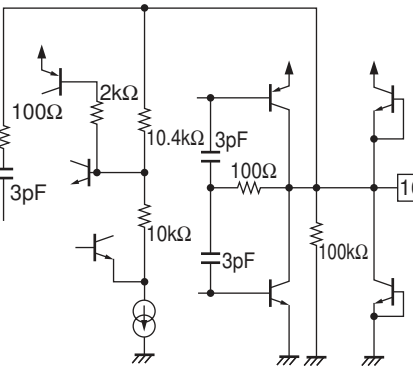
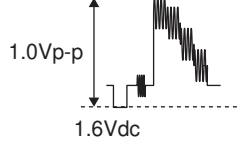
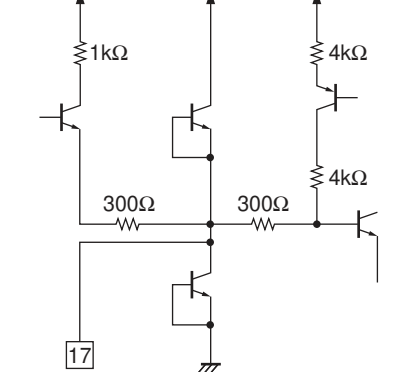
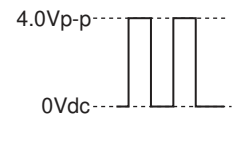
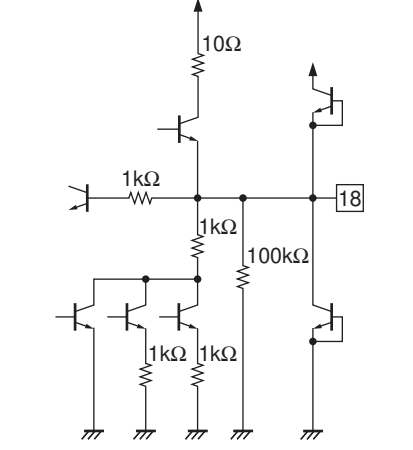
Pin No.	Pin name	DC voltage	Signal wave form	Input/Output form	Note
P14	AV1_V/Y_OUT	0.5Vdc +Video			
		0.5Vdc +Y			
P15	GND_VL				
P16	V_OUT (Line_OUT)	0.7Vdc +CVBS			
P17	AV1_V_IN	1.6Vdc +CVBS			
P18	AV1_FB_OUT	Low : 0V High : 4.0V Through : 0/4.0V			

Continued on next page.

LV7109E

Continued from preceding page.

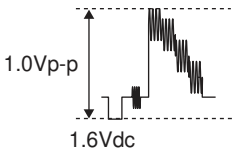
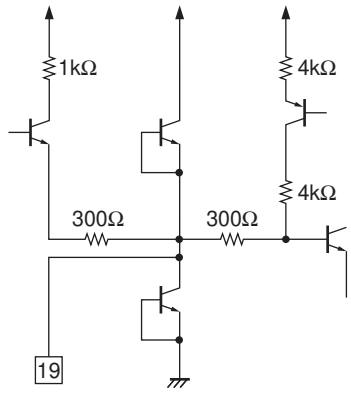
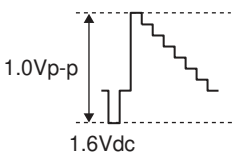
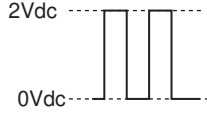
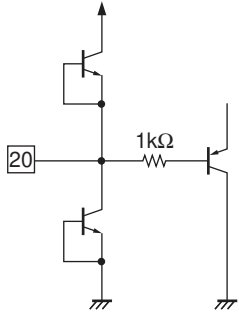
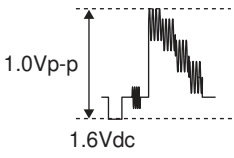
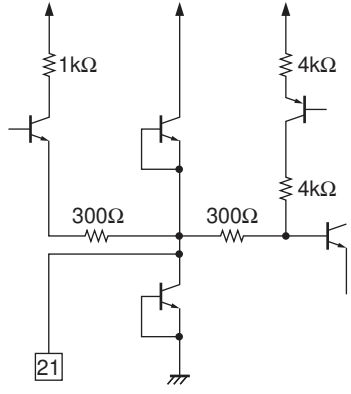
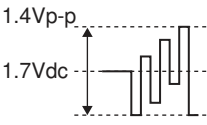
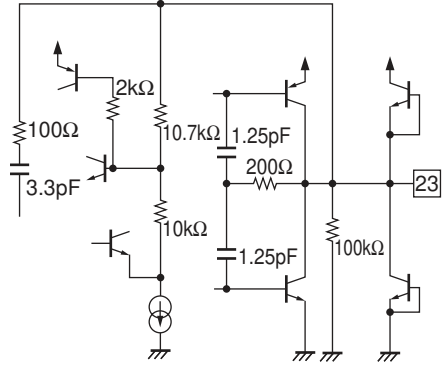
Pin No.	Pin name	DC voltage	Signal wave form	Input/Output form	Note
P19	AV2_V/Y_IN	1.6Vdc +CVBS			
		1.6Vdc +Y			
P20	AV1_FB_IN	Low : 0V High : 2V			
P21	AV3_V_IN	1.6Vdc +CVBS			
P22	GND_VD				
P23	PB_OUT (Component)	1.7V +Pb			
P24	VCC5V_VD				

Continued on next page.

LV7109E

Continued from preceding page.

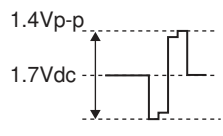
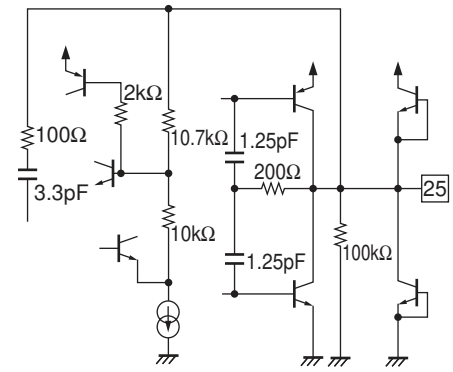
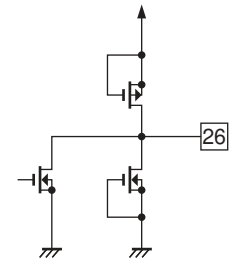
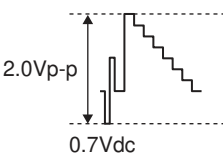
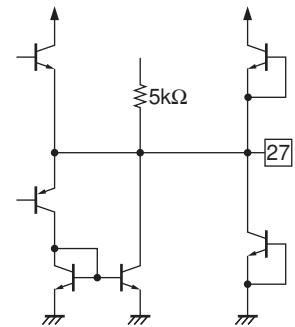
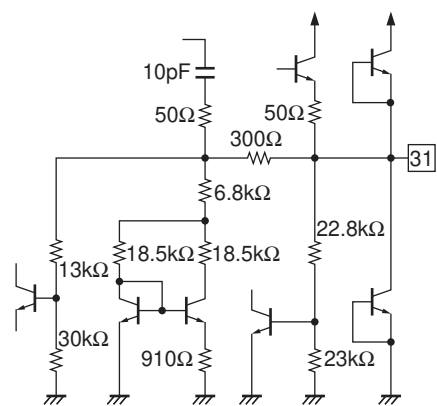
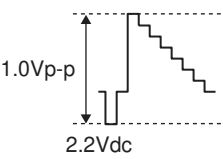
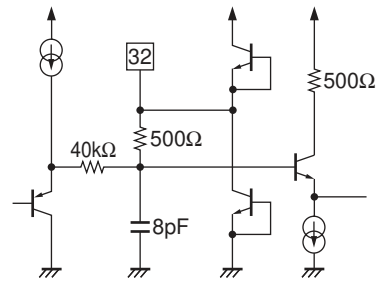
Pin No.	Pin name	DC voltage	Signal wave form	Input/Output form	Note
P25	PR_OUT (Component)	1.7V +Pr			
P26	EXT-CTL1 (OUT)	Low : 0V High : 5V			
P27	PY_OUT (Component)	0.7Vdc +Py			
P28	V _{CC} 5V_ALL				
P29	V _{CC} 12V_A				
P30	V _{CC} 5V_LOGIC				
P31	REG2.5V_ALL	2.5Vdc	DC		
P32	SYNC_SEP _FILTER	2.2Vdc +Y			

Continued on next page.

LV7109E

Continued from preceding page.

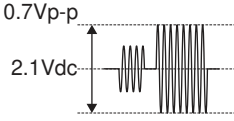
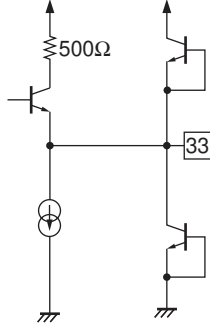
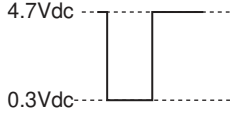
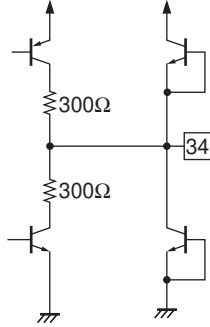
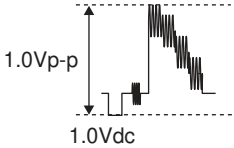
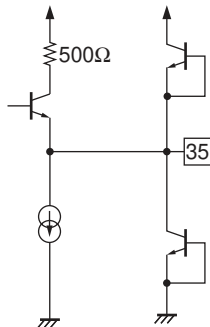
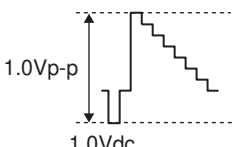
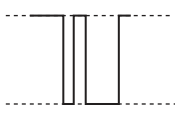
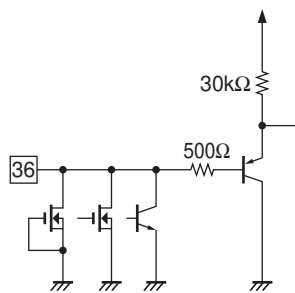
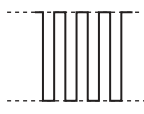
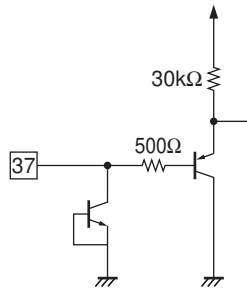
Pin No.	Pin name	DC voltage	Signal wave form	Input/Output form	Note
P33	ADC_C_OUT	2.1Vdc +Chroma			
P34	V_SYNC_OUT	Low : 0.3V High : 4.7V			
P35	ADC_V/Y_OUT	1.0Vdc +CVBS			
		1.0Vdc +Y			
P36	SDA_IN	I ² C DATA			ACK_OUT
P37	SCL_IN	I ² C CLOCK			

Continued on next page.

LV7109E

Continued from preceding page.

Pin No.	Pin name	DC voltage	Signal wave form	Input/Output form	Note
P38	ENC_C_IN	2.1Vdc +Chroma			
P39	GNG_LOGIC				
P40	ENC_Y_IN	1.6Vdc +Y			
P41	GND_VSW				
P42	ENC_R/PR_IN	1.6Vdc +Red			
		2.1Vdc +Pr			
P43	VCC5V_SW				
P44	ENC_G/PY_IN	1.6Vdc +Green			
		1.6Vdc +Py			
P45	GNG_REF				

Continued on next page.

LV7109E

Continued from preceding page.

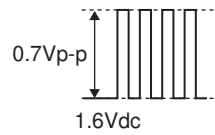
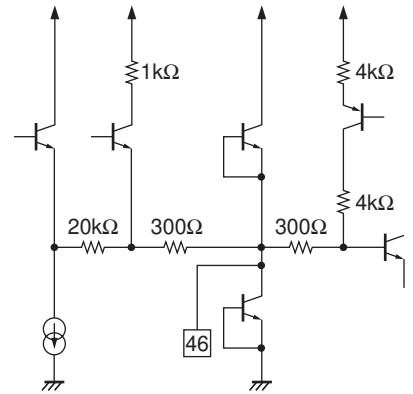
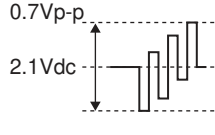
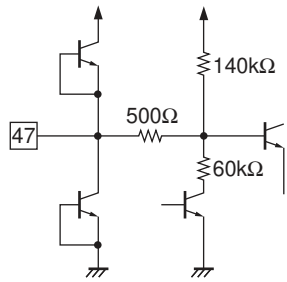
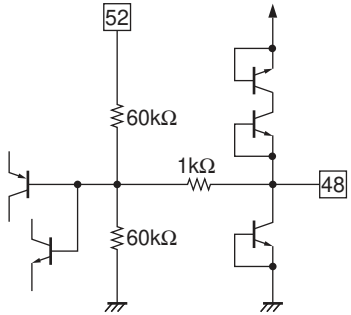
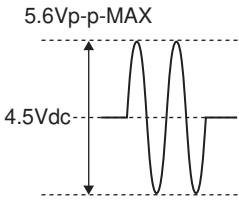
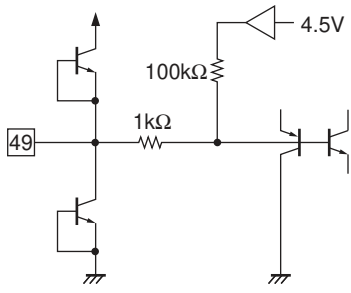
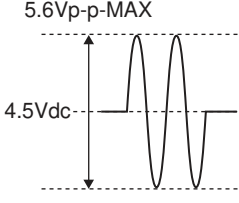
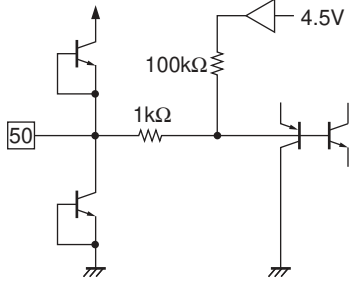
Pin No.	Pin name	DC voltage	Signal wave form	Input/Output form	Note
P46	ENC_B/PB_IN	1.6Vdc +Blue			
		2.1Vdc +Pb			
P47	Audio_Mute_Filter				
P48	REF4.5V	4.5Vdc	DC		
P49	A-DAC_R_IN	4.5Vdc +Right			
P50	AV2_R_IN	4.5Vdc +Right			

Continued on next page.

LV7109E

Continued from preceding page.

Pin No.	Pin name	DC voltage	Signal wave form	Input/Output form	Note
P51	AV1_R_IN	4.5Vdc +Right			
P52	REG9V_AR	9Vdc	DC		
P53	GND_REG				
P54	A-DAC_L_IN	4.5Vdc +Left			
P55	AV2_L_IN	4.5Vdc +Left			
P56	AV1_L_IN	4.5Vdc +Left			

Continued on next page.

LV7109E

Continued from preceding page.

Pin No.	Pin name	DC voltage	Signal wave form	Input/Output form	Note
P57	REG9V_AL	9Vdc	DC		
P58	AV2_R_OUT	4.5Vdc +Right			
P59	AV2_L_OUT	4.5Vdc +Left			
P60	GND_AR				
P61	AV1_R_OUT	4.5Vdc +Right			
P62	AV1_L_OUT	4.5Vdc +Left			
P63	GND_AL				

Continued on next page.

LV7109E

Continued from preceding page.

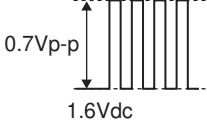
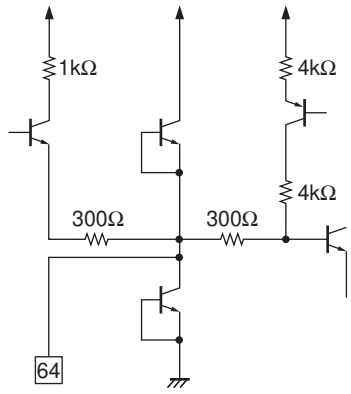
Pin No.	Pin name	DC voltage	Signal wave form	Input/Output form	Note
P64	AV2_B_IN	1.6Vdc +Blue			

ON Semiconductor and the ON logo are registered trademarks of Semiconductor Components Industries, LLC (SCILLC). SCILLC owns the rights to a number of patents, trademarks, copyrights, trade secrets, and other intellectual property. A listing of SCILLC's product/patent coverage may be accessed at www.onsemi.com/site/pdf/Patent-Marking.pdf. SCILLC reserves the right to make changes without further notice to any products herein. SCILLC makes no warranty, representation or guarantee regarding the suitability of its products for any particular purpose, nor does SCILLC assume any liability arising out of the application or use of any product or circuit, and specifically disclaims any and all liability, including without limitation special, consequential or incidental damages. "Typical" parameters which may be provided in SCILLC data sheets and/or specifications can and do vary in different applications and actual performance may vary over time. All operating parameters, including "Typicals" must be validated for each customer application by customer's technical experts. SCILLC does not convey any license under its patent rights nor the rights of others. SCILLC products are not designed, intended, or authorized for use as components in systems intended for surgical implant into the body, or other applications intended to support or sustain life, or for any other application in which the failure of the SCILLC product could create a situation where personal injury or death may occur. Should Buyer purchase or use SCILLC products for any such unintended or unauthorized application, Buyer shall indemnify and hold SCILLC and its officers, employees, subsidiaries, affiliates, and distributors harmless against all claims, costs, damages, and expenses, and reasonable attorney fees arising out of, directly or indirectly, any claim of personal injury or death associated with such unintended or unauthorized use, even if such claim alleges that SCILLC was negligent regarding the design or manufacture of the part. SCILLC is an Equal Opportunity/Affirmative Action Employer. This literature is subject to all applicable copyright laws and is not for resale in any manner.