

THIS DRAWING IS UNPUBLISHED. RELEASED FOR PUBLICATION
 © COPYRIGHT - By - ALL RIGHTS RESERVED.

LOC	DIST	REVISIONS					
FT	47	P	LTR	DESCRIPTION	DATE	DWN	APVD
		E1		REVISED PER ECO-14-001124	24JAN2014	NK	MZ

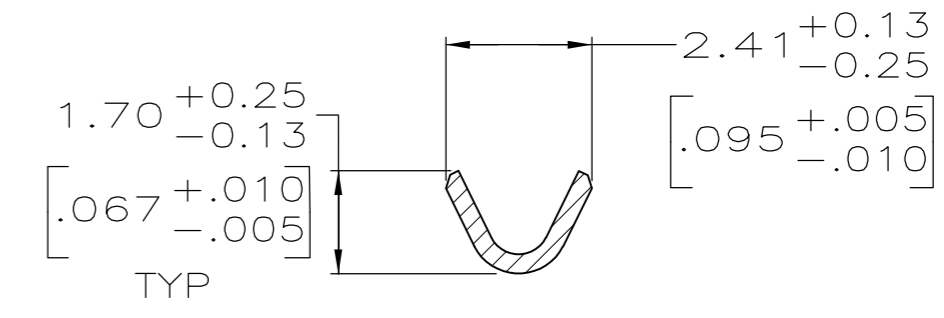

SECTION A-A

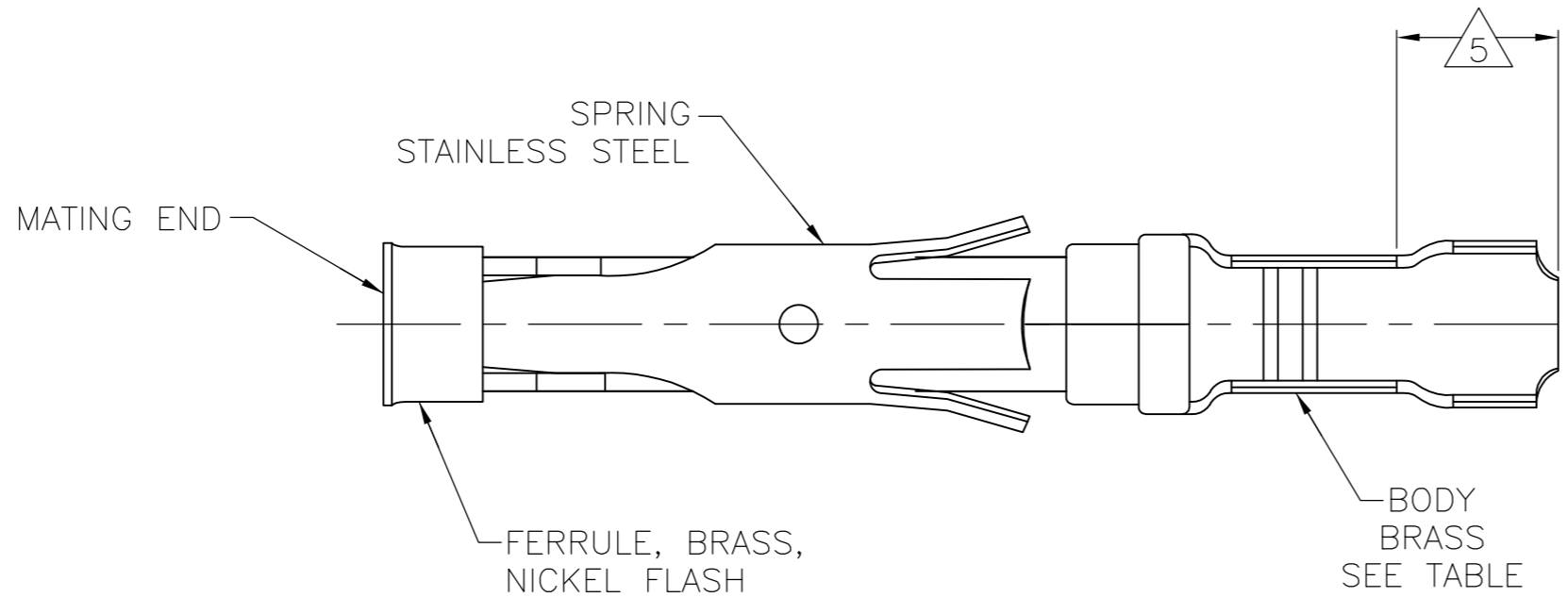
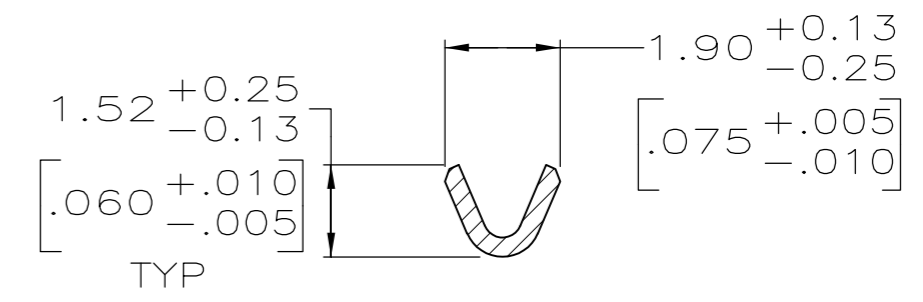
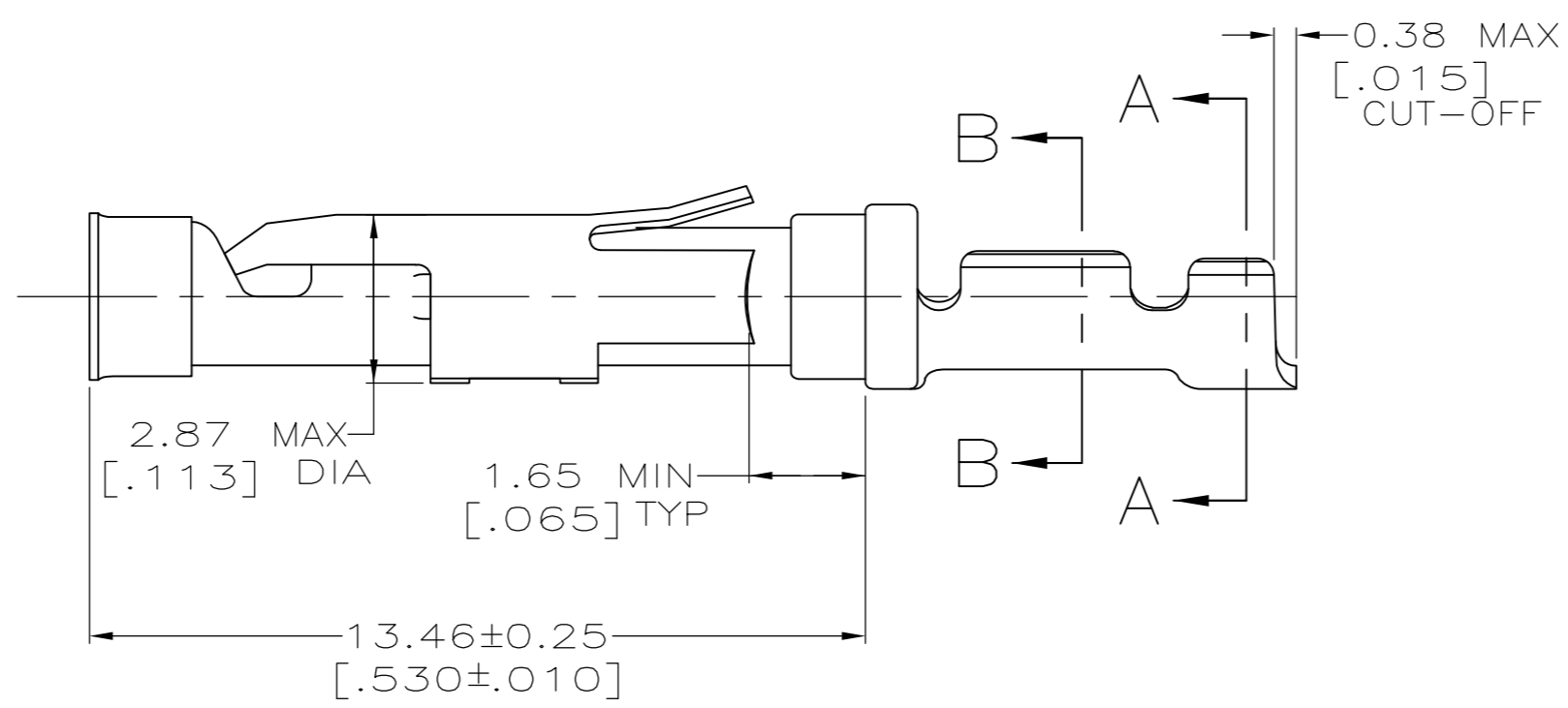
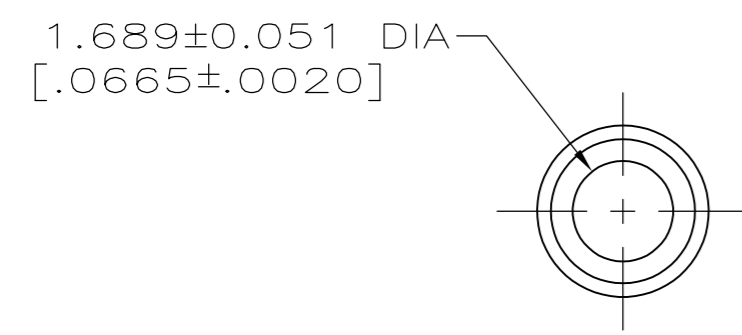

SECTION B-B

- 1 0.76µm [.000030] MIN GOLD PER MIL-G-45204 ON MATING END FOR A LENGTH OF 5.08 [.200] MIN WITH 1.27µm [.000050] MIN MATTE TIN PLATE IN WIRE CRIMP AREA, BOTH OVER 0.76µm [.000030] MIN NICKEL PER QQ-N-290.
- 2 1.27µm [.000050] MIN TIN-LEAD PER MIL-T-10727 OVER 0.76µm [.000030] MIN NICKEL PER QQ-N-290.
- 3 0.76µm [.000030] MIN GOLD PER MIL-G-45204 ON MATING END FOR A LENGTH OF 5.08 [.200] MIN WITH A UNIFORM GRADIENT TO 0.25µm [.000010] MIN GOLD PER MIL-G-45204 ON THE REMAINDER OVER 0.76µm [.000030] MIN NICKEL PER QQ-N-290.
- 4 0.38µm [.000015] MIN GOLD PER MIL-G-45204 ON MATING END FOR A LENGTH OF 5.08 [.200] MIN WITH 1.27µm [.000050] MIN MATTE TIN PLATE IN WIRE CRIMP AREA, BOTH OVER 0.76µm [.000030] MIN NICKEL PER QQ-N-290.
- 5 GOLD PLATING NOT REQUIRED IN THIS AREA.
- 6 WIRE RANGE 26-24 AWG. INSULATION RANGE 0.89[.035]-1.40[.055].
- 7 0.38µm [.000015] MIN GOLD PER MIL-G-45204 ON MATING END FOR A LENGTH OF 5.08 [.200] MIN, 1.27µm [.000050] MIN TIN-LEAD PER MIL-T-10727 FOR A LENGTH OF 5.69 [.224] MIN ON OPPOSITE END, BOTH OVER 1.27µm [.000050] MIN NICKEL PER QQ-N-290 ON ENTIRE CONTACT.
- 8 1.27µm [.000050] MIN TIN PER MIL-T-10727 OVER 0.76µm [.000030] MIN NICKEL PER QQ-N-290.
- 9 OBSOLETE PARTS: OBSOLETE CIS STREAMLINING PER D.RENAUD/D.SINISI

	SMALL PACK	8	1-66108-5 OR 1-66108-7	1-66109-8
	STANDARD	8	1-66108-5 OR 1-66108-7	1-66109-7
	SMALL PACK	1	66108-4	1-66109-6
	SMALL PACK	2	66108-2	1-66109-5
9	OBSOLETE - SMALL PACK	3	66108-1	1-66109-4
	OBSOLETE - STANDARD	7	1-66108-4	1-66109-3
	STANDARD	1	66108-4	66109-4
	STANDARD	4	66108-3	66109-3
	STANDARD	2	66108-2	66109-2
	STANDARD	3	66108-1	66109-1
	PACKAGING TYPE	BODY FINISH	STRIP P/N REF	PART NO

THIS DRAWING IS A CONTROLLED DOCUMENT.

DIMENSIONS: mm [INCHES]	TOLERANCES UNLESS OTHERWISE SPECIFIED:	DWN L.SIPE 06/02/92	TE Connectivity
0 PLC ± -	1 PLC ± -	CHK W.LENKER 6-11-92	
2 PLC ± 0.13 [.005]	3 PLC ± -	APVD G.STEINHAUER 7-8-92	NAME
4 PLC ± -	ANGLES ± -	PRODUCT SPEC	SOCKET ASSEMBLY, LOOSE PIECE, TYPE III+
MATERIAL SEE CALLOUTS	FINISH SEE CALLOUTS	APPLICATION SPEC	SIZE CAGE CODE DRAWING NO RESTRICTED TO
		WEIGHT	A2 00779 C=66109
		CUSTOMER DRAWING	SCALE 8:1 SHEET 1 OF 1 REV E1