

LOC		DIST		REVISIONS			
AD	00	REV	DATE	BY	CHK	APPV	
02		REVISED PER ECO-08-009171	22APR08	DH	AS		

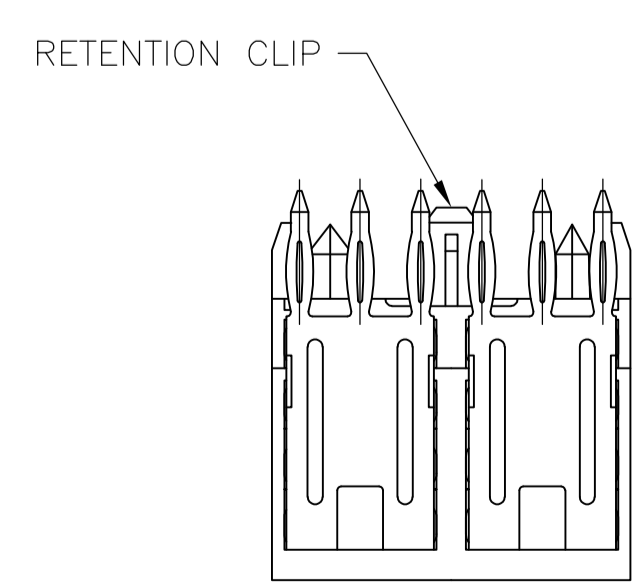

- ① HOUSING MATERIAL: LIQUID CRYSTAL POLYMER.
- ② CONTACT MATERIAL: PHOSPHOR-BRONZE.
- ③ CONTACT FINISH:(D)  
 UNDERPLATE (ENTIRE CONTACT):  
 0.00127 MIN NICKEL PER SAE-AMS-QQ-N-290  
 ON MATING SURFACES:  
 FLASH GOLD PER ASTM B 488, OVER  
 0.00076 MIN PALLADIUM-NICKEL OVER UNDERPLATE, OR  
 0.00076 MIN GOLD PER ASTM B 488 OVER UNDERPLATE.  
 ON LEADS:  
 0.00127 MIN MATTE TIN PER ASTM B 545 OVER UNDERPLATE.  
 LUBRICATION (MIN MATING SURFACES):  
 SURFACE CONDITIONER AFTER PLATING.

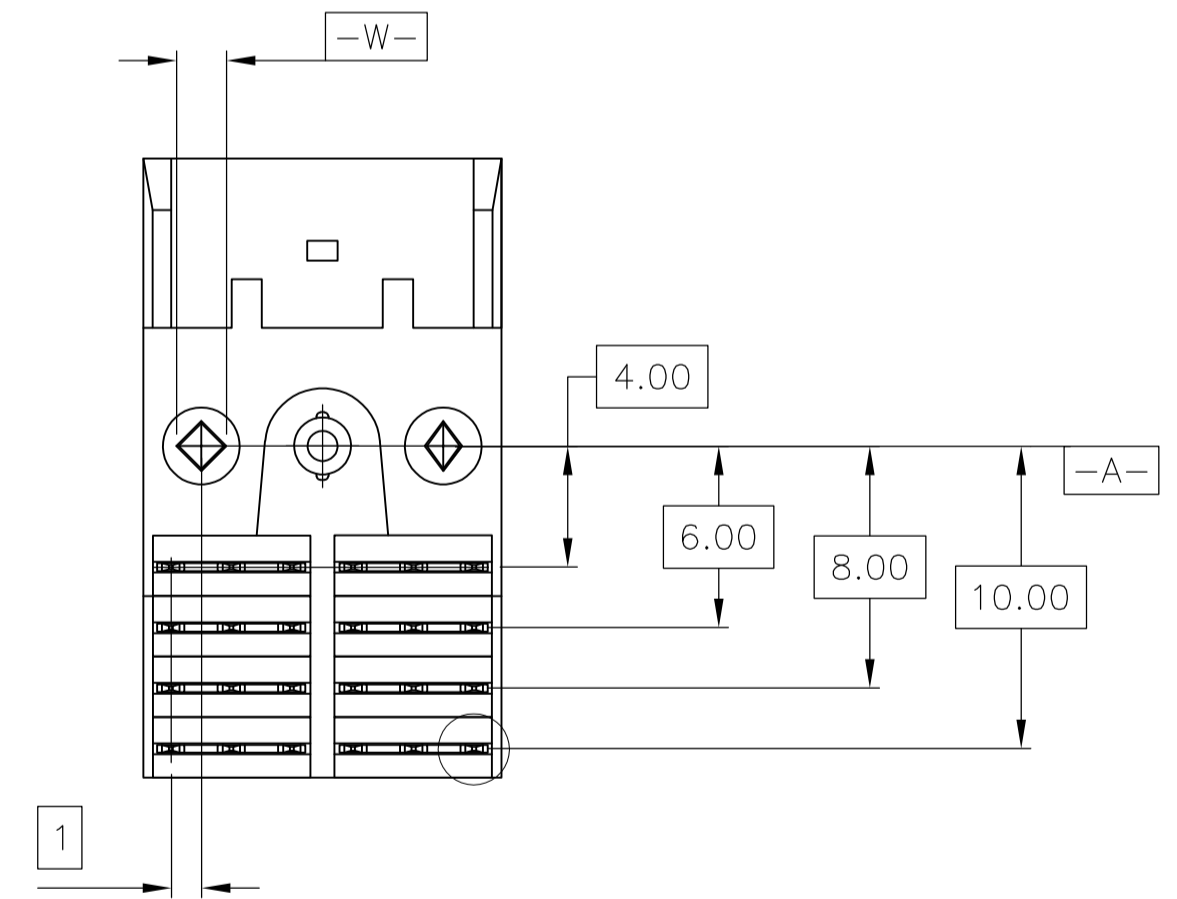
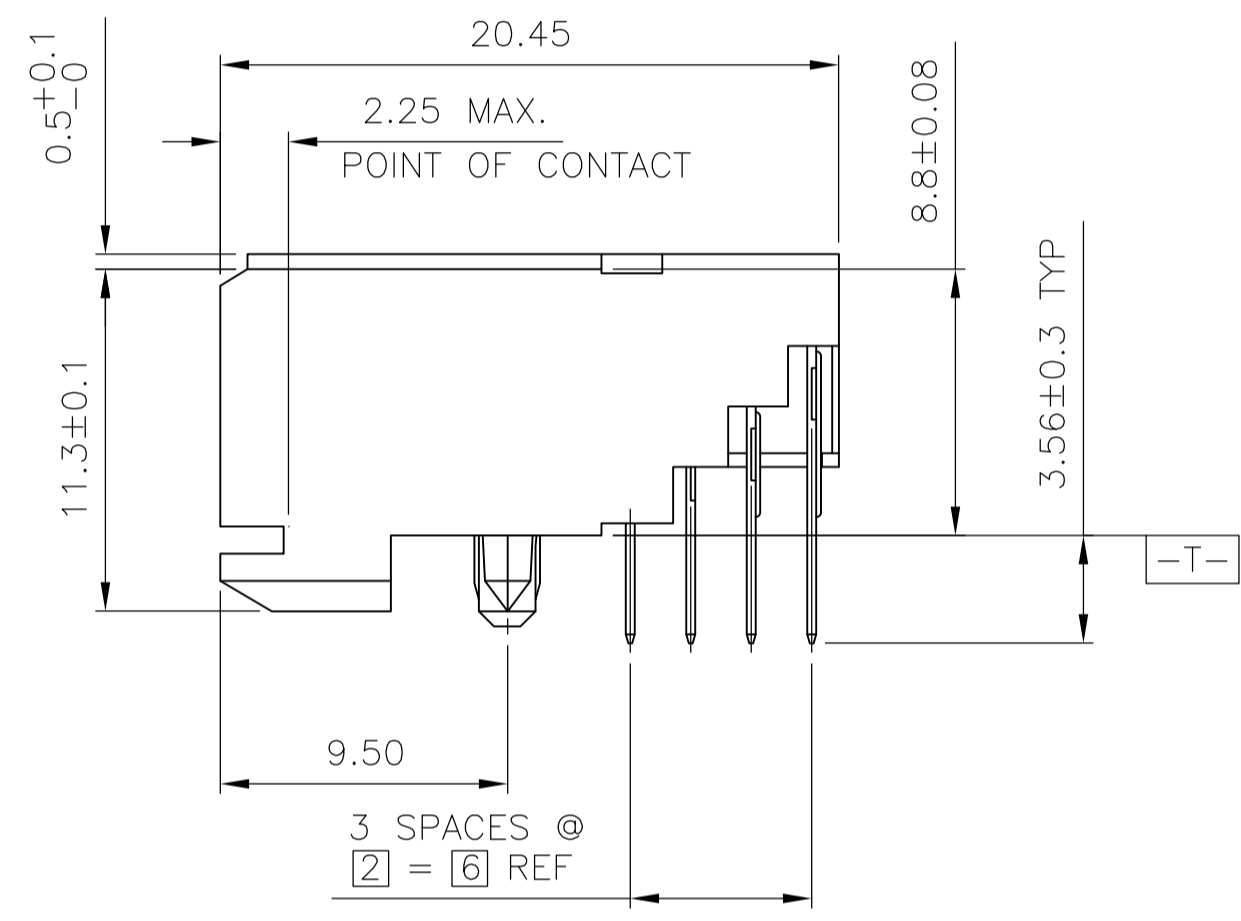
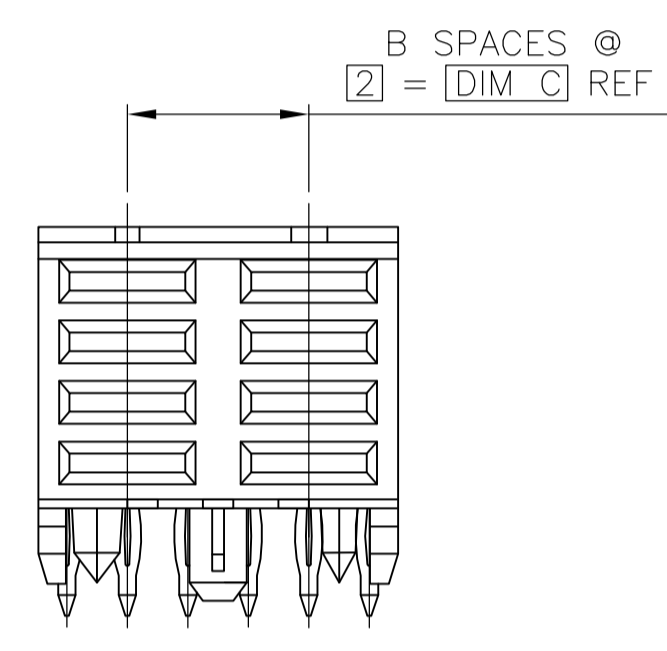
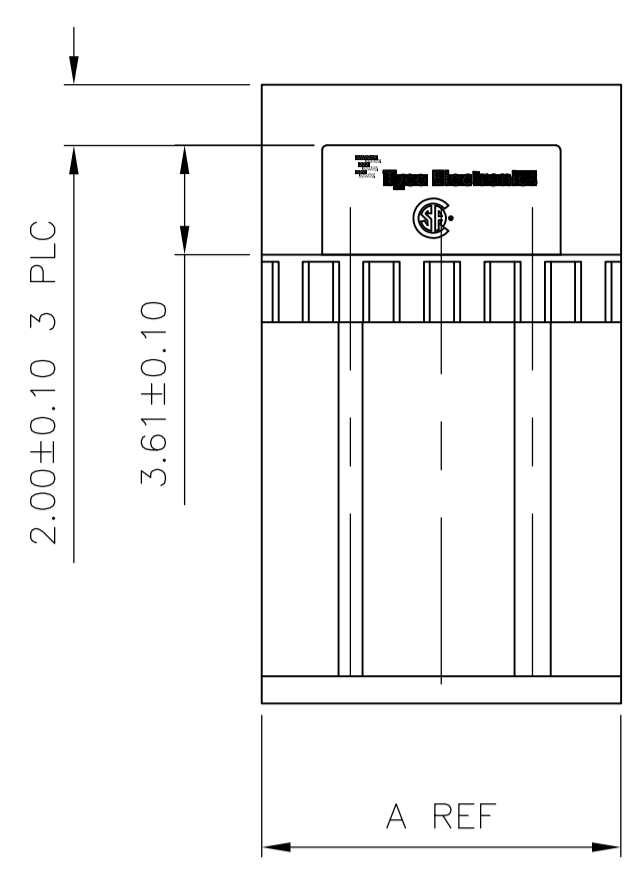
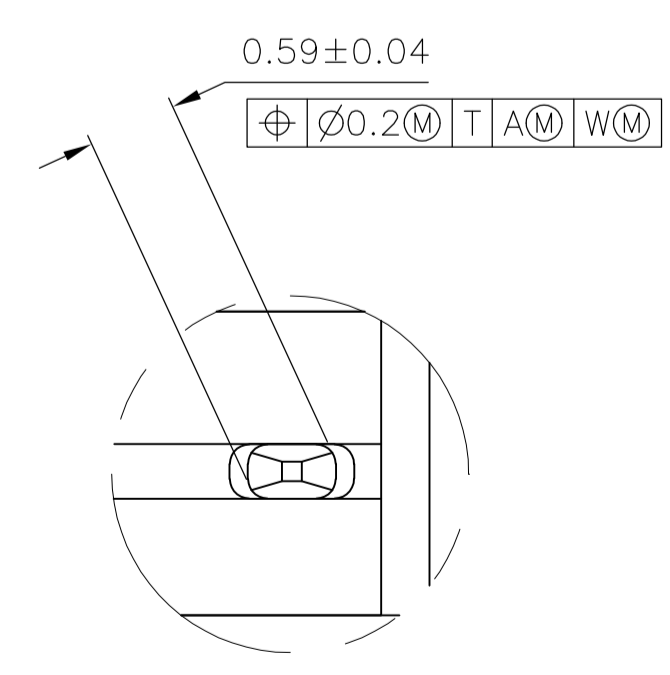
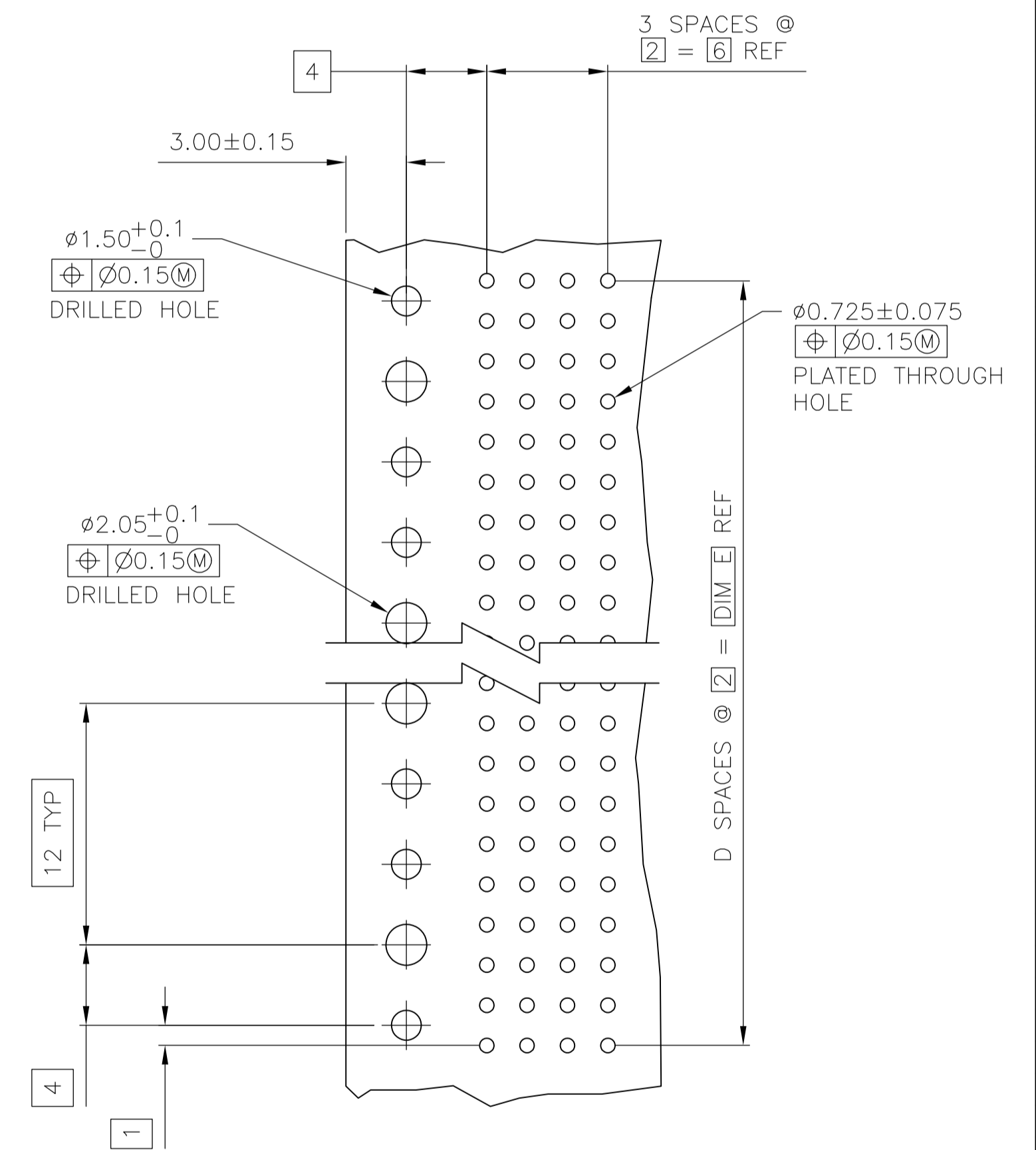

DETAIL Z  
SCALE 20:1

RECOMMENDED CIRCUIT PATTERN  
PER IPC-D300 TYPE II, CLASS C  
(COMPONENT SIDE)

10	5	6	1	11.88	③	8	5536614-1																		
E	D	C	B	A	FINISH	NO OF POSN	PART NUMBER																		
THIS DRAWING IS A CONTROLLED DOCUMENT.		DIN D.R.BENDER 11/04/92		S.HAEFER 04/20/93		Tyco Electronics Corporation Harrisburg, PA 17105-3608																			
DIMENSIONS: mm		TOLERANCES UNLESS OTHERWISE SPECIFIED:		PRODUCT SPEC		NAME: Z-PACK 2mm FB, POWER MODULE, RCPT. ASSY. 4 ROW, 3.56mm LEAD LENGTH PRESS FIT LEAD																			
<table border="1"> <tr><td>0 PLC</td><td>±</td><td>-</td></tr> <tr><td>1 PLC</td><td>±</td><td>-</td></tr> <tr><td>2 PLC</td><td>±</td><td>0.13</td></tr> <tr><td>3 PLC</td><td>±</td><td>-</td></tr> <tr><td>4 PLC</td><td>±</td><td>-</td></tr> <tr><td>ANGLES</td><td>±</td><td>-</td></tr> </table>		0 PLC	±	-	1 PLC	±	-	2 PLC	±	0.13	3 PLC	±	-	4 PLC	±	-	ANGLES	±	-	APPLICATION SPEC		SIZE: A1		CAGE CODE: 00779	
0 PLC	±	-																							
1 PLC	±	-																							
2 PLC	±	0.13																							
3 PLC	±	-																							
4 PLC	±	-																							
ANGLES	±	-																							
MATERIAL: ① ② ③		FINISH: ③		WEIGHT: -		DRAWING NO: 5536614																			
CUSTOMER DRAWING		SCALE: 4:1		SHEET: 1 OF 1		REV: 02																			