

PD-1160

57/60mm | NEMA23/24
 Stepper Motor with
 Controller / Driver
 0.55 - 3.1Nm / 48V
 sensOstep™ Encoder
 Serial Interface

INFO The PANdrive **PD57-1160** and **PD60-1160** family is a mechatronic solution including a 57mm or 60mm flange motor, a control-board and a **sensOstep™** encoder. It can be controlled via serial interface or operated in standalone mode. Power supply, external encoder, interface and I/Os can be connected with JST connectors.

With the advanced **stallGuard2™** the motor load can be detected with high resolution. The outstanding **coolStep™** technology for sensorless load dependent current control allows efficient motor operation.

The PC based software development environment **TMCL-IDE** for the Trinamic Motion Control Language **TMCL™** can be downloaded free of charge from the **TRINAMIC** website.

MAIN CHARACTERISTICS

- ELECTRICAL DATA**
 - Supply voltage 9V to 51V
- MOTOR DATA**
 - flange size 57/60mm | NEMA23/24
- INTERFACE**
 - USB, RS485, CAN
 - step&direction interface
 - inputs for ref. & stop switches
 - 4 general purpose I/Os
 - incremental a/b/n encoder interface
- FEATURES**
 - up to 256 times microstepping
 - memory for 2048 **TMCL™** commands
 - **stallGuard2™** sensorless load detection
 - **coolStep™** sensorless load dependent current control
 - **microPlyer™** 16 to 256 times microstepping interpolation
 - integrated absolute **sensOstep™** encoder with 1024 ppr.
 - automatic ramp generation in hardware
 - on the fly alteration of motion parameters
- SOFTWARE**
 - standalone operation using **TMCL** or remote controlled operation
 - PC-based (Windows) application development software **TMCL-IDE** downloadable
 - ready for **CANopen**
- OTHER**
 - RoHS compliant
 - size 60 x 60mm²

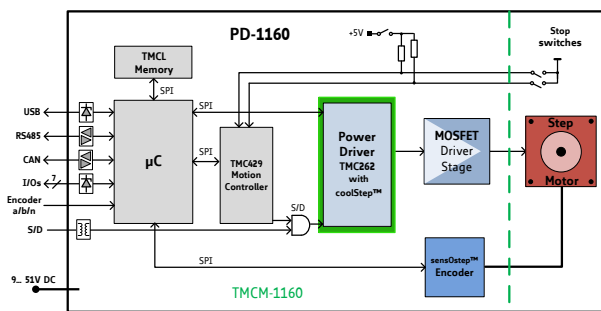

ORDER CODE	DESCRIPTION
PD57-1-1160	0.55 Nm / QMot motor QSH5718-41-28-055
PD57-2-1160	1.01 Nm / QMot motor QSH5718-51-28-101
PD60-3-1160	2.10 Nm / QMot motor QSH6018-65-28-210
PD60-4-1160	3.10 Nm / QMot motor QSH6018-86-28-310
PD-1160-CABLE	Cable loom including all necessary cables (single ended)