

# 74AUP2T1326

Low-power dual supply buffer/line driver; 3-state

Rev. 2 — 3 July 2012

Product data sheet

## 1. General description

---

The 74AUP2T1326 is a high-performance, dual supply, low-power, low-voltage, dual buffer/line driver with output enable circuitry.

The 74AUP2T1326 is designed for logic-level translation and combines the functions of the 74AUP1G32 and 74AUP2G126. The buffer/line driver is controlled by two output enable inputs (1OE and 2OE). A logic LOW on input 1OE causes the output 2Y to assume a high-impedance OFF-state, a logic LOW on 2OE causes the output 3Y to assume a high-impedance OFF-state. The output 1Y is the result of a logic OR of the two output enable inputs.

The output enable inputs (1OE and 2OE) are Schmitt trigger inputs, they switch at different voltages for positive and negative-going signals. The difference between the positive voltage  $V_{T+}$  and the negative voltage  $V_{T-}$  is defined as the input hysteresis voltage  $V_H$ . The output enable inputs accept standard input signals and are capable of transforming slowly changing input signals into sharply defined, jitter-free output signals.

Both  $V_{CC(A)}$  and  $V_{CC(B)}$  can be supplied at any voltage between 1.1 V and 3.6 V making the device suitable for interfacing between any of the low voltage nodes (1.2 V, 1.5 V, 1.8 V, 2.5 V and 3.3 V) with compatible input levels. Pins 1OE, 2OE and 1Y are referenced to  $V_{CC(A)}$  and pins A, 2Y and 3Y are referenced to  $V_{CC(B)}$ .

The device ensures low static and dynamic power consumption and is fully specified for partial power down applications using  $I_{OFF}$ . The  $I_{OFF}$  circuitry disables the outputs, preventing any damaging backflow current through the device when it is powered down.

## 2. Features and benefits

---

- Wide supply voltage range:
  - ◆  $V_{CC(A)}$ : 1.1 V to 3.6 V;  $V_{CC(B)}$ : 1.1 V to 3.6 V.
- High noise immunity
- Complies with JEDEC standards:
  - ◆ JESD8-7 (1.2 V to 1.95 V)
  - ◆ JESD8-5 (1.8 V to 2.7 V)
  - ◆ JESD8-B (2.7 V to 3.6 V)
- ESD protection:
  - ◆ HBM JESD22-A114F Class 2A exceeds 2000 V
  - ◆ MM JESD22-A115-A exceeds 200 V
  - ◆ CDM JESD22-C101E exceeds 1000 V
- Low static power consumption;  $I_{CC} = 0.9 \mu\text{A}$  (maximum)
- Latch-up performance exceeds 100 mA per JESD 78 Class II

- Inputs accept voltages up to 3.6 V
- Low noise overshoot and undershoot < 10 % of  $V_{CC}$
- $I_{OFF}$  circuitry provides partial Power-down mode operation
- Multiple package options
- Specified from  $-40\text{ }^{\circ}\text{C}$  to  $+85\text{ }^{\circ}\text{C}$

### 3. Ordering information

Table 1. Ordering information

Type number	Package			Version
	Temperature range	Name	Description	
74AUP2T1326GF	$-40\text{ }^{\circ}\text{C}$ to $+85\text{ }^{\circ}\text{C}$	XSON10	plastic extremely thin small outline package; no leads; 10 terminals; body 1 x 1.7 x 0.5 mm	SOT1081-2

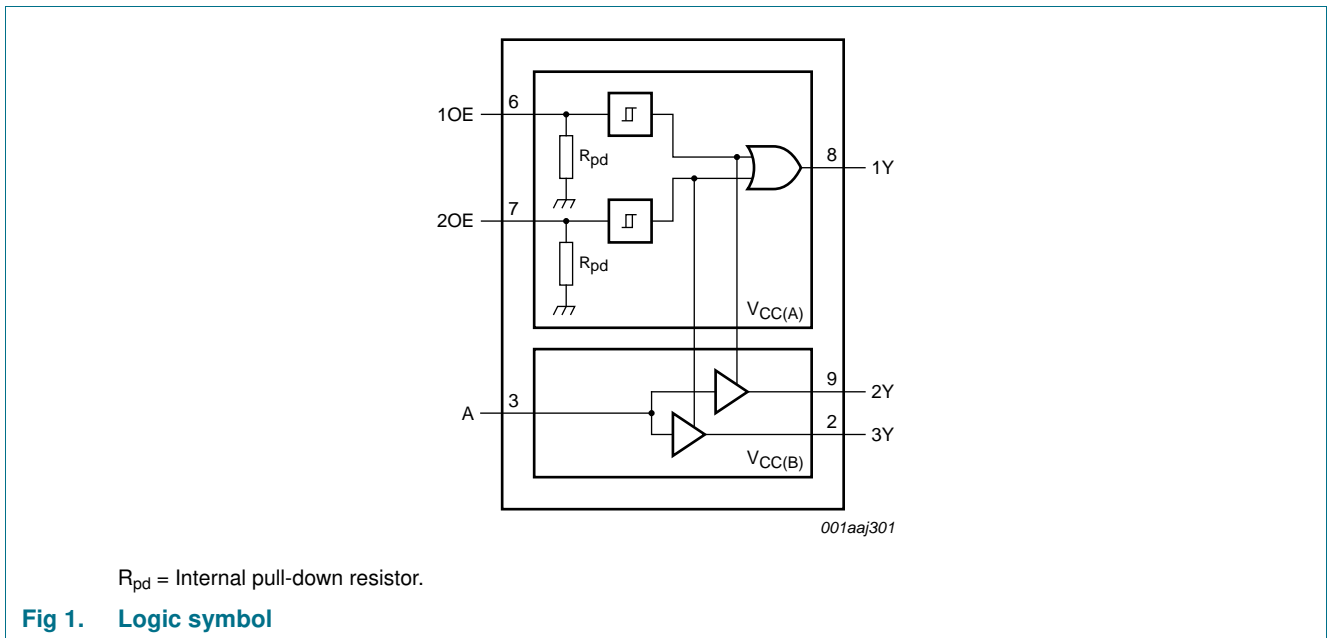
### 4. Marking

Table 2. Marking

Type number	Marking code <sup>[1]</sup>
74AUP2T1326GF	pf

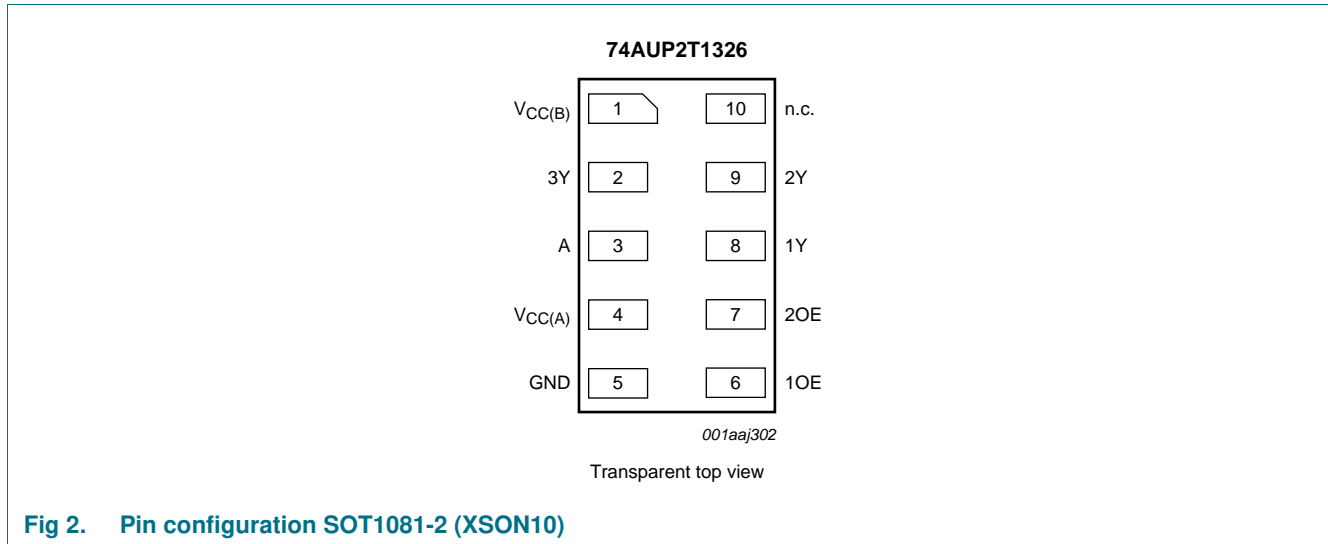
[1] The pin 1 indicator is located on the lower left corner of the device, below the marking code.

### 5. Functional diagram



## 6. Pinning information

### 6.1 Pinning



### 6.2 Pin description

**Table 3. Pin description**

Symbol	Pin	Description
V <sub>CC(B)</sub>	1	supply voltage B
3Y	2	data output
A	3	data input
V <sub>CC(A)</sub>	4	supply voltage A
GND	5	ground (0 V)
1OE	6	output enable input (Schmitt trigger input)
2OE	7	output enable input (Schmitt trigger input)
1Y	8	data output
2Y	9	data output
n.c.	10	not connected

## 7. Functional description

Table 4. Function table<sup>[1]</sup>

Input			Output		
1OE	2OE	A	1Y	2Y	3Y
L	L	X	L	Z	Z
L	H	L	H	Z	L
L	H	H	H	Z	H
H	L	L	H	L	Z
H	L	H	H	H	Z
H	H	L	H	L	L
H	H	H	H	H	H

[1] H = HIGH voltage level; L = LOW voltage level; X = don't care; Z = high-impedance OFF-state.

## 8. Limiting values

Table 5. Limiting values

In accordance with the Absolute Maximum Rating System (IEC 60134). Voltages are referenced to GND (ground = 0 V).

Symbol	Parameter	Conditions	Min	Max	Unit
$V_{CC(A)}$	supply voltage A		-0.5	+4.6	V
$V_{CC(B)}$	supply voltage B		-0.5	+4.6	V
$I_{IK}$	input clamping current	$V_I < 0$ V	-50	-	mA
$V_I$	input voltage		<sup>[1]</sup> -0.5	+4.6	V
$I_{OK}$	output clamping current	$V_O < 0$ V	<sup>[2]</sup> -50	-	mA
$V_O$	output voltage	Active mode and Power-down mode	<sup>[1]</sup> -0.5	+4.6	V
$I_O$	output current	$V_O = 0$ V to $V_{CCO}$	<sup>[2]</sup> -	±20	mA
$I_{CC}$	supply current		-	50	mA
$I_{GND}$	ground current		-50	-	mA
$T_{stg}$	storage temperature		-65	+150	°C
$P_{tot}$	total power dissipation	$T_{amb} = -40$ °C to +85 °C	<sup>[3]</sup> -	250	mW

[1] The minimum input and output voltage ratings may be exceeded if the input and output current ratings are observed.

[2]  $V_{CCO}$  is the supply voltage associated with an output pin.

[3] For XSON10 package: above 45 °C the value of  $P_{tot}$  derates linearly with 2.4 mW/K.

## 9. Recommended operating conditions

Table 6. Recommended operating conditions

Symbol	Parameter	Conditions	Min	Max	Unit
$V_{CC(A)}$	supply voltage A		1.1	3.6	V
$V_{CC(B)}$	supply voltage B		1.1	3.6	V
$V_I$	input voltage		0	3.6	V
$V_O$	output voltage		<sup>[1]</sup> 0	$V_{CCO}$	V

Table 6. Recommended operating conditions ...continued

Symbol	Parameter	Conditions	Min	Max	Unit
$T_{amb}$	ambient temperature		-40	+85	°C
$\Delta t/\Delta V$	input transition rise and fall rate	input A; $V_{CCI} = 1.1 \text{ V to } 3.6 \text{ V}$	[2] -	200	ns/V
		input nOE; $V_{CCI} = 1.1 \text{ V to } 3.6 \text{ V}$	[2] -	30	ms/V

[1]  $V_{CCO}$  is the supply voltage associated with an output pin.

[2]  $V_{CCI}$  is the supply voltage associated with an input pin.

## 10. Static characteristics

Table 7. Static characteristics

At recommended operating conditions; voltages are referenced to GND (ground = 0 V).

Symbol	Parameter	Conditions	25 °C			-40 °C to +85 °C		Unit
			Min	Typ	Max	Min	Max	
$V_{IH}$	HIGH-level input voltage	input A; [1][3] $V_{CCI} = 1.65 \text{ V to } 1.95 \text{ V}$	$0.65V_{CCI}$	-	-	$0.65V_{CCI}$	-	V
		$V_{CCI} = 2.3 \text{ V to } 2.7 \text{ V}$	1.6	-	-	1.6	-	V
$V_{IL}$	LOW-level input voltage	input A; [1][3] $V_{CCI} = 1.65 \text{ V to } 1.95 \text{ V}$	-	-	$0.35V_{CCI}$	-	$0.35V_{CCI}$	V
		$V_{CCI} = 2.3 \text{ V to } 2.7 \text{ V}$	-	-	0.7	-	0.7	V
$V_{OH}$	HIGH-level output voltage	$V_I = V_{IL}$ or $V_I$ or $V_I = V_{T+}$ or $V_{T-}$						
		$I_O = -20 \mu\text{A}$ ; $V_{CCO} = 1.65 \text{ V to } 2.7 \text{ V}$ [2]	$V_{CCO} - 0.1$	-	-	$V_{CCO} - 0.1$	-	V
		$I_O = -3 \text{ mA}$ ; $V_{CCO} = 1.65 \text{ V}$	1.2	-	-	1.2	-	V
		$I_O = -2.3 \text{ mA}$ ; $V_{CCO} = 2.3 \text{ V}$	1.97	-	-	1.97	-	V
		$I_O = -4.0 \text{ mA}$ ; $V_{CCO} = 2.3 \text{ V}$	2.0	-	-	2.0	-	V
$V_{OL}$	LOW-level output voltage	$V_I = V_{IL}$ or $V_I$ or $V_I = V_{T+}$ or $V_{T-}$ [2]						
		$I_O = 20 \mu\text{A}$ ; $V_{CCO} = 1.65 \text{ V to } 2.7 \text{ V}$	-	-	0.10	-	0.10	V
		$I_O = 3.0 \text{ mA}$ ; $V_{CCO} = 1.65 \text{ V}$	-	-	0.45	-	0.45	V
		$I_O = 2.3 \text{ mA}$ ; $V_{CCO} = 2.3 \text{ V}$	-	-	0.33	-	0.33	V
		$I_O = 4.0 \text{ mA}$ ; $V_{CCO} = 2.3 \text{ V}$	-	-	0.40	-	0.40	V
$I_I$	input leakage current	input A; $V_I = 0 \text{ V to } 2.7 \text{ V}$ ; $V_{CCI} = 1.65 \text{ V to } 2.7 \text{ V}$ [1]	-	-	$\pm 0.1$	-	$\pm 0.5$	$\mu\text{A}$
$I_{OZ}$	OFF-state output current	output 2Y, 3Y; $V_I = V_{IH}$ or $V_{IL}$ ; $V_O = 0 \text{ V to } 2.7 \text{ V}$ ; $V_{CC(A)} = 1.65 \text{ V to } 2.7 \text{ V}$ ; $V_{CC(B)} = 1.65 \text{ V to } 2.7 \text{ V}$	-	-	$\pm 0.1$	-	$\pm 0.5$	$\mu\text{A}$
$I_{OFF}$	power-off leakage current	1Y; $V_{CC(A)} = 0 \text{ V}$ ; $V_O = 0 \text{ V to } 2.7 \text{ V}$ ; $V_{CC(B)} = 1.65 \text{ V to } 2.7 \text{ V}$	-	-	$\pm 0.2$	-	$\pm 0.5$	$\mu\text{A}$
		A, 2Y, 3Y; $V_{CC(B)} = 0 \text{ V}$ ; $V_I$ or $V_O = 0 \text{ V to } 2.7 \text{ V}$ ; $V_{CC(A)} = 1.65 \text{ V to } 2.7 \text{ V}$	-	-	$\pm 0.2$	-	$\pm 0.5$	$\mu\text{A}$

**Table 7. Static characteristics ...continued**

At recommended operating conditions; voltages are referenced to GND (ground = 0 V).

Symbol	Parameter	Conditions	25 °C			–40 °C to +85 °C		Unit
			Min	Typ	Max	Min	Max	
$\Delta I_{OFF}$	additional power-off leakage current	1Y; $V_{CC(A)} = 0\text{ V to }0.2\text{ V}$ ; $V_O = 0\text{ V to }2.7\text{ V}$ ; $V_{CC(B)} = 1.65\text{ V to }2.7\text{ V}$	-	-	$\pm 0.2$	-	$\pm 0.6$	$\mu\text{A}$
		A, 2Y, 3Y; $V_{CC(B)} = 0\text{ V to }0.2\text{ V}$ ; $V_I$ or $V_O = 0\text{ V to }2.7\text{ V}$ ; $V_{CC(A)} = 1.65\text{ V to }2.7\text{ V}$	-	-	$\pm 0.2$	-	$\pm 0.6$	$\mu\text{A}$
$I_{CC(A)}$	supply current A	$V_I = 0\text{ V or }V_{CC(A)}$ ; $I_O = 0\text{ A}$ [1]	-	-	0.5	-	0.9	$\mu\text{A}$
		$V_{CC(A)} = 1.65\text{ V to }2.7\text{ V}$ ; $V_{CC(B)} = 0\text{ V to }2.7\text{ V}$	-	-	0.5	-	0.9	$\mu\text{A}$
$I_{CC(B)}$	supply current B	$V_I = 0\text{ V or }V_{CC(B)}$ ; $I_O = 0\text{ A}$ [1]	-	-	0.5	-	0.9	$\mu\text{A}$
		$V_{CC(A)} = V_{CC(B)} = 1.65\text{ V to }2.7\text{ V}$ ;	-	-	0.5	-	0.9	$\mu\text{A}$
		$V_{CC(A)} = 1.71\text{ V}$ ; $V_{CC(B)} = 2.6\text{ V}$	-	-	500	-	750	$\mu\text{A}$
$\Delta I_{CC}$	additional supply current	nOE; $V_{CC(A)} = V_{CC(B)} = 2.7\text{ V}$ ; $V_I = V_{CC(A)} - 0.6\text{ V}$	-	-	40	-	50	$\mu\text{A}$
		A; $V_{CC(A)} = V_{CC(B)} = 2.7\text{ V}$ ; $V_I = V_{CC(B)} - 0.6\text{ V}$ ;	-	-	80	-	100	$\mu\text{A}$
		A; $V_I = \text{GND to }2.7\text{ V}$ ; nOE = GND; $V_{CC(A)} = 1.65\text{ V to }2.7\text{ V}$ ; $V_{CC(B)} = 1.65\text{ V to }2.7\text{ V}$	[4]	-	2	-	2	$\mu\text{A}$
$R_{pd}$	pull-down resistance		145	200	255	140	260	k $\Omega$
$C_I$	input capacitance	input A; $V_I = 0\text{ V or }V_{CCI}$ ; $V_{CCI} = 1.65\text{ V to }2.7\text{ V}$	[1]	-	0.9	-	-	pF
		input nOE; $V_I = 0\text{ V or }V_{CCI}$ ; $V_{CCI} = 1.65\text{ V to }2.7\text{ V}$	[1]	-	0.8	-	-	pF
$C_O$	output capacitance	1Y; $V_O = \text{GND}$ ; $V_{CCO} = 0\text{ V}$	[2]	-	1.7	-	-	pF
		2Y, 3Y enabled; $V_O = \text{GND}$ ; $V_{CCO} = 0\text{ V}$	[2]	-	1.7	-	-	pF
		2Y, 3Y disabled; $V_{CCO} = 0\text{ V to }2.7\text{ V}$ ; $V_O = \text{GND or }V_{CCO}$	[2]	-	1.5	-	-	pF

[1]  $V_{CCI}$  is the supply voltage associated with the input pin.[2]  $V_{CCO}$  is the supply voltage associated with the output pin.[3] For  $V_{CCI}$  values not specified in the data sheet: minimum  $V_{IH} = 0.7 \times V_{CCI}$  and maximum  $V_{IL} = 0.3 \times V_{CCI}$ .[4] To show  $I_{CC}$  remains very low when the input-disable feature is enabled.

## 11. Dynamic characteristics

**Table 8. Dynamic characteristics**

Voltages are referenced to GND (ground = 0 V); for test circuit see [Figure 5](#).

Symbol	Parameter	Conditions	25 °C			−40 °C to +85 °C		Unit
			Min	Typ <sup>[1]</sup>	Max	Min	Max	
<b><math>C_L = 5 \text{ pF}</math></b>								
$t_{pd}$	propagation delay	A to 2Y, 3Y; see <a href="#">Figure 3</a>	<a href="#">[2]</a>					
		$V_{CC(B)} = 1.65 \text{ V to } 1.95 \text{ V}$	1.9	3.2	4.5	1.7	5.0	ns
		$V_{CC(B)} = 2.3 \text{ V to } 2.7 \text{ V}$	1.5	2.6	3.4	1.3	3.8	ns
		nOE to 1Y; see <a href="#">Figure 3</a>	<a href="#">[2]</a>					
		$V_{CC(A)} = 1.65 \text{ V to } 1.95 \text{ V}$	2.4	4.0	5.4	2.2	6.0	ns
		$V_{CC(A)} = 2.3 \text{ V to } 2.7 \text{ V}$	2.2	3.2	3.9	2.0	4.3	ns
<b><math>C_L = 10 \text{ pF}</math></b>								
$t_{pd}$	propagation delay	A to 2Y, 3Y; see <a href="#">Figure 3</a>	<a href="#">[2]</a>					
		$V_{CC(B)} = 1.65 \text{ V to } 1.95 \text{ V}$	2.3	3.8	5.3	2.0	5.8	ns
		$V_{CC(B)} = 2.3 \text{ V to } 2.7 \text{ V}$	1.8	3.2	4.1	1.5	4.5	ns
		nOE to 1Y; see <a href="#">Figure 3</a>	<a href="#">[2]</a>					
		$V_{CC(A)} = 1.65 \text{ V to } 1.95 \text{ V}$	2.9	4.6	6.1	2.5	6.7	ns
		$V_{CC(A)} = 2.3 \text{ V to } 2.7 \text{ V}$	2.5	3.7	4.6	2.2	5.0	ns
<b><math>C_L = 5 \text{ pF}; V_{CC(A)} = 1.65 \text{ V to } 1.95 \text{ V}</math></b>								
$t_{en}$	enable time	nOE to 2Y, 3Y; see <a href="#">Figure 4</a>	<a href="#">[3]</a>					
		$V_{CC(B)} = 1.65 \text{ V to } 1.95 \text{ V}$	2.4	4.4	9.7	2.1	10.1	ns
		$V_{CC(B)} = 2.3 \text{ V to } 2.7 \text{ V}$	2.2	3.9	8.2	1.9	8.8	ns
$t_{dis}$	disable time	nOE to 2Y, 3Y; see <a href="#">Figure 4</a>	<a href="#">[4]</a>					
		$V_{CC(B)} = 1.65 \text{ V to } 1.95 \text{ V}$	2.4	4.5	8.9	2.1	9.4	ns
		$V_{CC(B)} = 2.3 \text{ V to } 2.7 \text{ V}$	2.2	3.8	7.8	1.9	8.4	ns
<b><math>C_L = 5 \text{ pF}; V_{CC(A)} = 2.3 \text{ V to } 2.7 \text{ V}</math></b>								
$t_{en}$	enable time	nOE to 2Y, 3Y; see <a href="#">Figure 4</a>	<a href="#">[3]</a>					
		$V_{CC(B)} = 1.65 \text{ V to } 1.95 \text{ V}$	2.4	4.0	8.7	2.1	9.0	ns
		$V_{CC(B)} = 2.3 \text{ V to } 2.7 \text{ V}$	2.2	3.4	7.2	1.9	7.7	ns
$t_{dis}$	disable time	nOE to 2Y, 3Y; see <a href="#">Figure 4</a>	<a href="#">[4]</a>					
		$V_{CC(B)} = 1.65 \text{ V to } 1.95 \text{ V}$	2.4	4.2	7.9	2.1	8.3	ns
		$V_{CC(B)} = 2.3 \text{ V to } 2.7 \text{ V}$	2.2	3.5	6.8	1.9	7.3	ns
<b><math>C_L = 10 \text{ pF}; V_{CC(A)} = 1.65 \text{ V to } 1.95 \text{ V}</math></b>								
$t_{en}$	enable time	nOE to 2Y, 3Y; see <a href="#">Figure 4</a>	<a href="#">[3]</a>					
		$V_{CC(B)} = 1.65 \text{ V to } 1.95 \text{ V}$	2.9	4.9	11.0	2.5	11.7	ns
		$V_{CC(B)} = 2.3 \text{ V to } 2.7 \text{ V}$	2.5	4.4	9.7	2.2	10.5	ns
$t_{dis}$	disable time	nOE to 2Y, 3Y; see <a href="#">Figure 4</a>	<a href="#">[4]</a>					
		$V_{CC(B)} = 1.65 \text{ V to } 1.95 \text{ V}$	2.9	5.6	10.8	2.5	11.5	ns
		$V_{CC(B)} = 2.3 \text{ V to } 2.7 \text{ V}$	2.5	4.6	9.5	2.2	10.1	ns

**Table 8. Dynamic characteristics ...continued**

Voltages are referenced to GND (ground = 0 V); for test circuit see [Figure 5](#).

Symbol	Parameter	Conditions	25 °C			–40 °C to +85 °C		Unit
			Min	Typ <sup>[1]</sup>	Max	Min	Max	
<b><math>C_L = 10 \text{ pF}</math>; <math>V_{CC(A)} = 2.3 \text{ V to } 2.7 \text{ V}</math></b>								
$t_{en}$	enable time	nOE to 2Y, 3Y; see <a href="#">Figure 4</a> <sup>[3]</sup>						
		$V_{CC(B)} = 1.65 \text{ V to } 1.95 \text{ V}$	2.9	4.5	10.0	2.5	10.5	ns
		$V_{CC(B)} = 2.3 \text{ V to } 2.7 \text{ V}$	2.5	3.9	8.7	2.2	9.3	ns
$t_{dis}$	disable time	nOE to 2Y, 3Y; see <a href="#">Figure 4</a> <sup>[4]</sup>						
		$V_{CC(B)} = 1.65 \text{ V to } 1.95 \text{ V}$	2.9	5.3	9.8	2.5	10.3	ns
		$V_{CC(B)} = 2.3 \text{ V to } 2.7 \text{ V}$	2.5	4.3	8.4	2.2	8.9	ns
<b><math>C_L = 5 \text{ pF and } 10 \text{ pF}</math></b>								
$C_{PD}$	power dissipation capacitance	per active output; <sup>[5]</sup> output 2Y, 3Y; $f_i = 1 \text{ MHz}$ ; $V_I = 0 \text{ V to } V_{CC}$						
		$V_{CC(A)} = V_{CC(B)} = 1.8 \text{ V}$	-	3.0	-	-	-	pF
		$V_{CC(A)} = V_{CC(B)} = 2.5 \text{ V}$	-	3.6	-	-	-	pF

[1] All typical values are measured at nominal  $V_{CC(A)}$  and  $V_{CC(B)}$ .

[2]  $t_{pd}$  is the same as  $t_{PLH}$  and  $t_{PHL}$ .

[3]  $t_{en}$  is the same as  $t_{PZH}$  and  $t_{PZL}$ .

[4]  $t_{dis}$  is the same as  $t_{PHZ}$  and  $t_{PLZ}$ .

[5]  $C_{PD}$  is used to determine the dynamic power dissipation ( $P_D$  in  $\mu\text{W}$ ).

$$P_D = C_{PD} \times V_{CC}^2 \times f_i \times N + \Sigma(C_L \times V_{CC}^2 \times f_o) \text{ where:}$$

$f_i$  = input frequency in MHz;

$f_o$  = output frequency in MHz;

$C_L$  = load capacitance in pF;

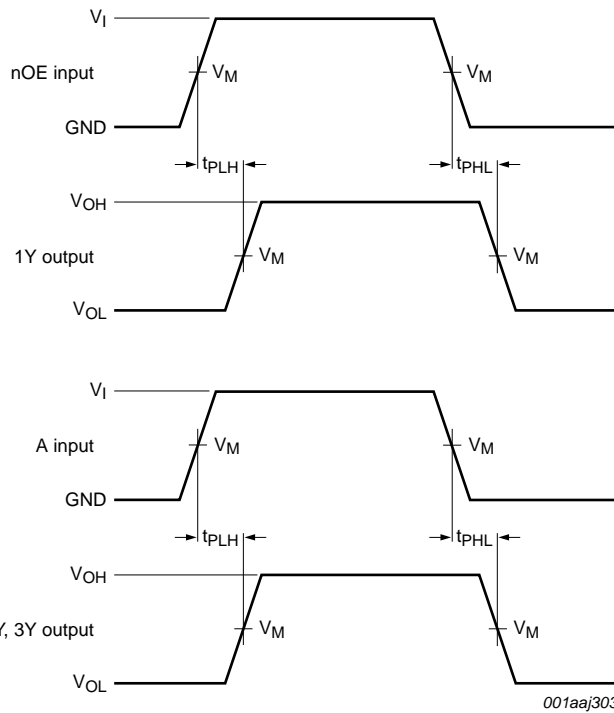
$V_{CC}$  = supply voltage in V;

$N$  = number of inputs switching;

$\Sigma(C_L \times V_{CC}^2 \times f_o)$  = sum of the outputs.

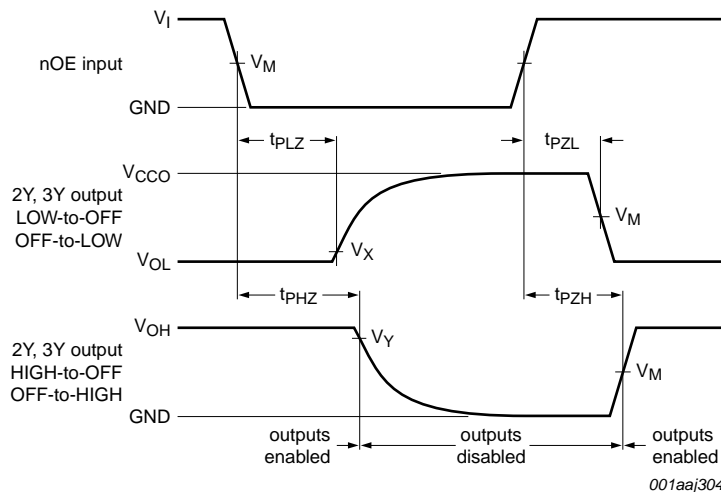


12. Waveforms



Measurement points are given in [Table 9](#).  
 $V_{OL}$  and  $V_{OH}$  are typical output voltage levels that occur with the output load.

**Fig 3. Input nOE to output 1Y and A to output 2Y, 3Y propagation delay times**



Measurement points are given in [Table 9](#).  
 $V_{OL}$  and  $V_{OH}$  are typical output voltage levels that occur with the output load.  
 $V_{CC0}$  is the supply voltage associated with the output pin.

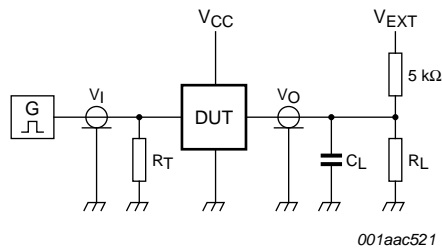
**Fig 4. Enable and disable times**

**Table 9. Measurement points**

Supply voltage	Input <sup>[1]</sup>	Output <sup>[2]</sup>		
$V_{CC(A)}, V_{CC(B)}$	$V_M$	$V_M$	$V_X$	$V_Y$
1.65 V to 2.7 V	$0.5V_{CCI}$	$0.5V_{CCO}$	$V_{OL} + 0.15 V$	$V_{OH} - 0.15 V$

[1]  $V_{CCI}$  is the supply voltage associated with the data input port.

[2]  $V_{CCO}$  is the supply voltage associated with the output port.



001aac521

Test data is given in [Table 10](#).

Definitions for test circuit:

$R_L$  = Load resistance.

$C_L$  = Load capacitance including jig and probe capacitance.

$R_T$  = Termination resistance should be equal to the output impedance  $Z_o$  of the pulse generator.

$V_{EXT}$  = External voltage for measuring switching times.

**Fig 5. Test circuit for measuring switching times**

**Table 10. Test data**

Supply voltage	Input		Load <sup>[2]</sup>		$V_{EXT}$		
$V_{CC(A)}, V_{CC(B)}$	$V_I$ <sup>[1]</sup>	$t_r = t_f$	$C_L$	$R_L$ <sup>[3]</sup>	$t_{PLH}, t_{PHL}$	$t_{PZH}, t_{PHZ}$	$t_{PZL}, t_{PLZ}$ <sup>[4]</sup>
1.65 V to 2.7 V	$V_{CCI}$	$\leq 3.0 \text{ ns}$	5 pF, 10 pF	5 kΩ or 1 MΩ	open	GND	$2V_{CCO}$

[1]  $V_{CCI}$  is the supply voltage associated with the data input port.

[2] For measuring enable and disable times,  $C_L$  and  $R_L$  are connected to pin 2Y and 3Y.

[3] For measuring enable and disable times  $R_L = 5 \text{ k}\Omega$ , for measuring propagation delays  $R_L = 1 \text{ M}\Omega$ .

[4]  $V_{CCO}$  is the supply voltage associated with the output port.

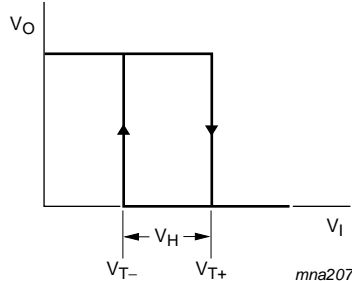
### 13. Transfer characteristics

**Table 11. Transfer characteristics**

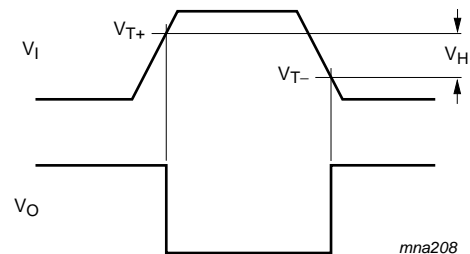
Voltages are referenced to GND (ground = 0 V; for test circuit see [Figure 5](#)).

Symbol	Parameter	Conditions	25 °C			-40 °C to +85 °C		Unit
			Min	Typ	Max	Min	Max	
$V_{T+}$	positive-going threshold voltage	nOE inputs; see <a href="#">Figure 6</a> and <a href="#">Figure 7</a>						
		$V_{CC(A)} = 1.65 \text{ V}$	0.91	-	1.29	0.91	1.29	V
		$V_{CC(A)} = 2.3 \text{ V}$	1.37	-	1.77	1.37	1.77	V
$V_{T-}$	negative-going threshold voltage	nOE inputs; see <a href="#">Figure 6</a> and <a href="#">Figure 7</a>						
		$V_{CC(A)} = 1.65 \text{ V}$	0.47	-	0.84	0.47	0.84	V
		$V_{CC(A)} = 2.3 \text{ V}$	0.69	-	1.04	0.69	1.04	V
$V_H$	hysteresis voltage	nOE inputs; ( $V_{T+} - V_{T-}$ ); see <a href="#">Figure 6</a> , <a href="#">Figure 7</a> and <a href="#">Figure 8</a>						
		$V_{CC(A)} = 1.65 \text{ V}$	0.27	-	0.66	0.27	0.66	V
		$V_{CC(A)} = 2.3 \text{ V}$	0.53	-	0.92	0.53	0.92	V

### 14. Waveforms transfer characteristics

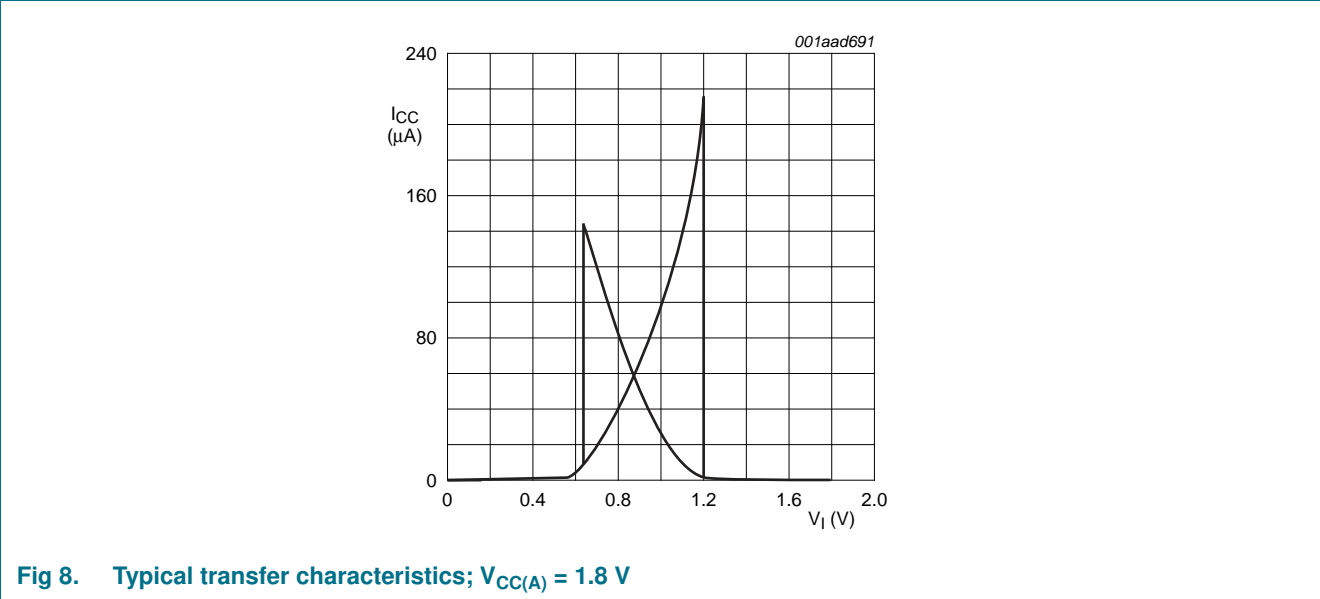


**Fig 6. Transfer characteristic**



$V_{T+}$  and  $V_{T-}$  limits at 70 % and 20 %.

**Fig 7. Definition of  $V_{T+}$ ,  $V_{T-}$  and  $V_H$**



15. Package outline

XSON10: plastic extremely thin small outline package; no leads;  
10 terminals; body 1.0 x 1.7 x 0.5 mm

SOT1081-2

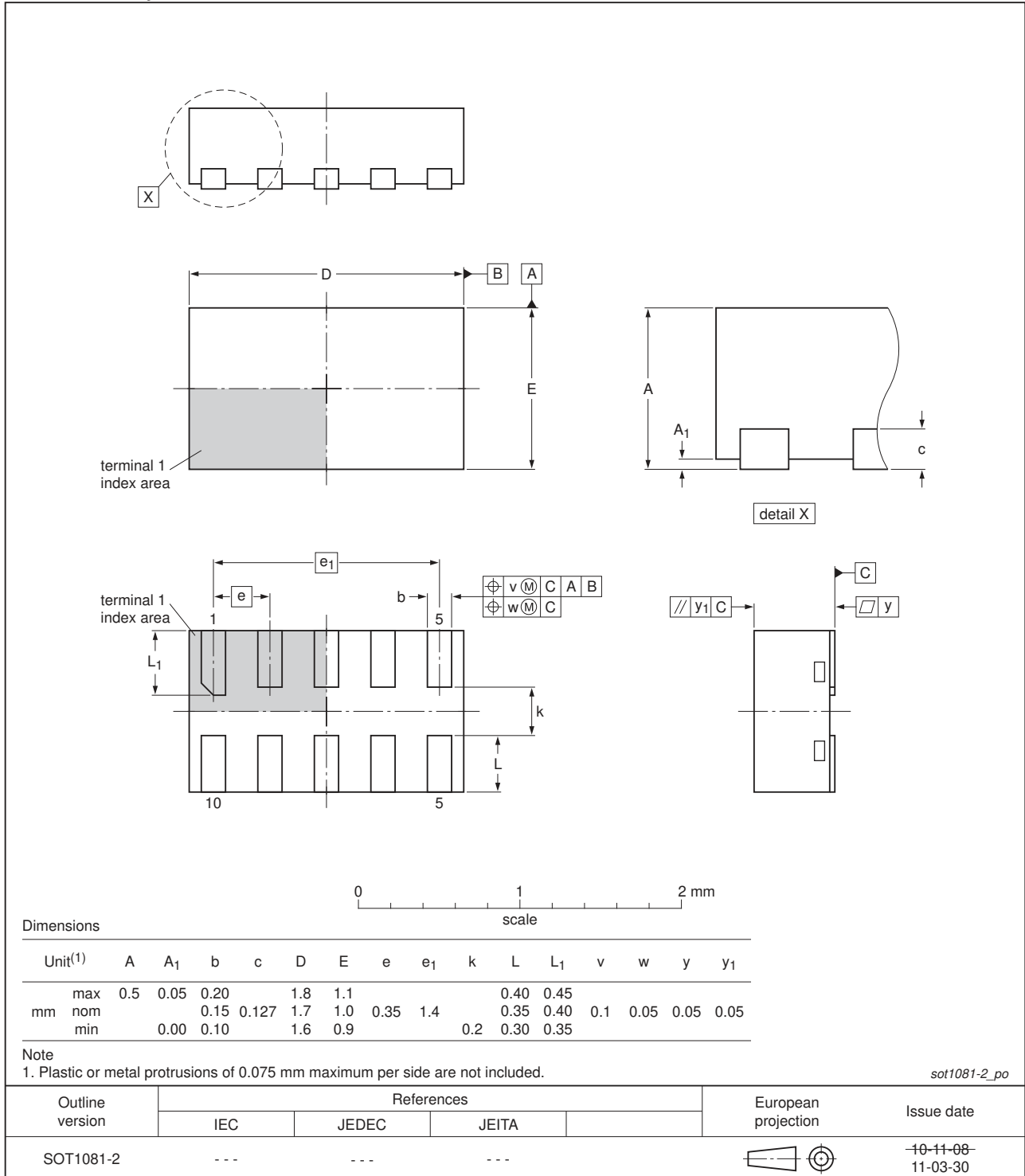


Fig 9. Package outline SOT1081-2 (XSON10)

## 16. Abbreviations

Table 12. Abbreviations

Acronym	Description
CDM	Charged Device Model
CMOS	Complementary Metal-Oxide Semiconductor
DUT	Device Under Test
ESD	ElectroStatic Discharge
HBM	Human Body Model
MM	Machine Model
TTL	Transistor-Transistor Logic

## 17. Revision history

Table 13. Revision history

Document ID	Release date	Data sheet status	Change notice	Supersedes
74AUP2T1326 v.2	20120703	Product data sheet	-	74AUP2T1326 v.1
Modifications:	• For type number 74AUP2T1326GF the sot code has changed to SOT1081-2.			
74AUP2T1326 v.1	20090701	Product data sheet	-	-

## 18. Legal information

### 18.1 Data sheet status

Document status <sup>[1][2]</sup>	Product status <sup>[3]</sup>	Definition
Objective [short] data sheet	Development	This document contains data from the objective specification for product development.
Preliminary [short] data sheet	Qualification	This document contains data from the preliminary specification.
Product [short] data sheet	Production	This document contains the product specification.

[1] Please consult the most recently issued document before initiating or completing a design.

[2] The term 'short data sheet' is explained in section "Definitions".

[3] The product status of device(s) described in this document may have changed since this document was published and may differ in case of multiple devices. The latest product status information is available on the Internet at URL <http://www.nexperia.com>.

### 18.2 Definitions

**Draft** — The document is a draft version only. The content is still under internal review and subject to formal approval, which may result in modifications or additions. Nexperia does not give any representations or warranties as to the accuracy or completeness of information included herein and shall have no liability for the consequences of use of such information.

**Short data sheet** — A short data sheet is an extract from a full data sheet with the same product type number(s) and title. A short data sheet is intended for quick reference only and should not be relied upon to contain detailed and full information. For detailed and full information see the relevant full data sheet, which is available on request via the local Nexperia sales office. In case of any inconsistency or conflict with the short data sheet, the full data sheet shall prevail.

**Product specification** — The information and data provided in a Product data sheet shall define the specification of the product as agreed between Nexperia and its customer, unless Nexperia and customer have explicitly agreed otherwise in writing. In no event however, shall an agreement be valid in which the Nexperia product is deemed to offer functions and qualities beyond those described in the Product data sheet.

### 18.3 Disclaimers

**Limited warranty and liability** — Information in this document is believed to be accurate and reliable. However, Nexperia does not give any representations or warranties, expressed or implied, as to the accuracy or completeness of such information and shall have no liability for the consequences of use of such information. Nexperia takes no responsibility for the content in this document if provided by an information source outside of Nexperia.

In no event shall Nexperia be liable for any indirect, incidental, punitive, special or consequential damages (including - without limitation - lost profits, lost savings, business interruption, costs related to the removal or replacement of any products or rework charges) whether or not such damages are based on tort (including negligence), warranty, breach of contract or any other legal theory.

Notwithstanding any damages that customer might incur for any reason whatsoever, Nexperia's aggregate and cumulative liability towards customer for the products described herein shall be limited in accordance with the *Terms and conditions of commercial sale* of Nexperia.

**Right to make changes** — Nexperia reserves the right to make changes to information published in this document, including without limitation specifications and product descriptions, at any time and without notice. This document supersedes and replaces all information supplied prior to the publication hereof.

**Suitability for use** — Nexperia products are not designed, authorized or warranted to be suitable for use in life support, life-critical or safety-critical systems or equipment, nor in applications where failure or malfunction of a Nexperia product can reasonably be expected to result in personal injury, death or severe property or environmental damage. Nexperia and its suppliers accept no liability for inclusion and/or use of Nexperia products in such equipment or applications and therefore such inclusion and/or use is at the customer's own risk.

**Applications** — Applications that are described herein for any of these products are for illustrative purposes only. Nexperia makes no representation or warranty that such applications will be suitable for the specified use without further testing or modification.

Customers are responsible for the design and operation of their applications and products using Nexperia products, and Nexperia accepts no liability for any assistance with applications or customer product design. It is customer's sole responsibility to determine whether the Nexperia product is suitable and fit for the customer's applications and products planned, as well as for the planned application and use of customer's third party customer(s). Customers should provide appropriate design and operating safeguards to minimize the risks associated with their applications and products.

Nexperia does not accept any liability related to any default, damage, costs or problem which is based on any weakness or default in the customer's applications or products, or the application or use by customer's third party customer(s). Customer is responsible for doing all necessary testing for the customer's applications and products using Nexperia products in order to avoid a default of the applications and the products or of the application or use by customer's third party customer(s). Nexperia does not accept any liability in this respect.

**Limiting values** — Stress above one or more limiting values (as defined in the Absolute Maximum Ratings System of IEC 60134) will cause permanent damage to the device. Limiting values are stress ratings only and (proper) operation of the device at these or any other conditions above those given in the Recommended operating conditions section (if present) or the Characteristics sections of this document is not warranted. Constant or repeated exposure to limiting values will permanently and irreversibly affect the quality and reliability of the device.

**Terms and conditions of commercial sale** — Nexperia products are sold subject to the general terms and conditions of commercial sale, as published at <http://www.nexperia.com/profile/terms>, unless otherwise agreed in a valid written individual agreement. In case an individual agreement is concluded only the terms and conditions of the respective agreement shall apply. Nexperia hereby expressly objects to applying the customer's general terms and conditions with regard to the purchase of Nexperia products by customer.

**No offer to sell or license** — Nothing in this document may be interpreted or construed as an offer to sell products that is open for acceptance or the grant, conveyance or implication of any license under any copyrights, patents or other industrial or intellectual property rights.

**Export control** — This document as well as the item(s) described herein may be subject to export control regulations. Export might require a prior authorization from competent authorities.

**Non-automotive qualified products** — Unless this data sheet expressly states that this specific Nexperia product is automotive qualified, the product is not suitable for automotive use. It is neither qualified nor tested in accordance with automotive testing or application requirements. Nexperia accepts no liability for inclusion and/or use of non-automotive qualified products in automotive equipment or applications.

In the event that customer uses the product for design-in and use in automotive applications to automotive specifications and standards, customer (a) shall use the product without Nexperia's warranty of the product for such automotive applications, use and specifications, and (b) whenever customer uses the product for automotive applications beyond

Nexperia's specifications such use shall be solely at customer's own risk, and (c) customer fully indemnifies Nexperia for any liability, damages or failed product claims resulting from customer design and use of the product for automotive applications beyond Nexperia's standard warranty and Nexperia's product specifications.

**Translations** — A non-English (translated) version of a document is for reference only. The English version shall prevail in case of any discrepancy between the translated and English versions.

## 18.4 Trademarks

Notice: All referenced brands, product names, service names and trademarks are the property of their respective owners.

## 19. Contact information

For more information, please visit: <http://www.nexperia.com>

For sales office addresses, please send an email to: [salesaddresses@nexperia.com](mailto:salesaddresses@nexperia.com)



## 20. Contents

---

1	General description . . . . .	1
2	Features and benefits . . . . .	1
3	Ordering information . . . . .	2
4	Marking . . . . .	2
5	Functional diagram . . . . .	2
6	Pinning information . . . . .	3
6.1	Pinning . . . . .	3
6.2	Pin description . . . . .	3
7	Functional description . . . . .	4
8	Limiting values . . . . .	4
9	Recommended operating conditions . . . . .	4
10	Static characteristics . . . . .	5
11	Dynamic characteristics . . . . .	7
12	Waveforms . . . . .	9
13	Transfer characteristics . . . . .	11
14	Waveforms transfer characteristics . . . . .	11
15	Package outline . . . . .	13
16	Abbreviations . . . . .	14
17	Revision history . . . . .	14
18	Legal information . . . . .	15
18.1	Data sheet status . . . . .	15
18.2	Definitions . . . . .	15
18.3	Disclaimers . . . . .	15
18.4	Trademarks . . . . .	16
19	Contact information . . . . .	16
20	Contents . . . . .	17