

8B39

Current Output Modules



Description

8B modules are an optimal solution for monitoring real-world process signals and providing high-level signals to a data acquisition system. Each 8B39 module accepts an input signal from a non-isolated source, then isolates, filters, and converts the signal to an analog process current output (Figure 1).

Signal filtering is accomplished with a 3-pole filter optimized for time and frequency response which provides 60dB per decade of normal-mode rejection above 100Hz. One pole of this filter is on the system side and the other two are on the isolated field side.

A special output circuit in the 8B39 module provides protection against accidental connection of power-line voltages up to 40VAC continuous. Clamp circuits on the I/O and power terminals protect against harmful transients.

The modules are designed for installation in Class I, Division 2 hazardous locations and have a high level of immunity to environmental noise.

Features

- Accepts High-Level Voltage or Process Current Input
- Process Current Output
- 1500Vrms Isolation
- ANSI/IEEE C37.90.1 Transient Protection
- Output Protection to 40VAC Continuous
- 110dB CMR
- 100Hz Signal Bandwidth
- $\pm 0.05\%$ Accuracy
- $\pm 0.02\%$ Linearity
- Low Drift with Ambient Temperature
- C-UL-US Listed
- CE Compliant
- ATEX Compliance Pending
- Mix and Match Module Types on Backpanel

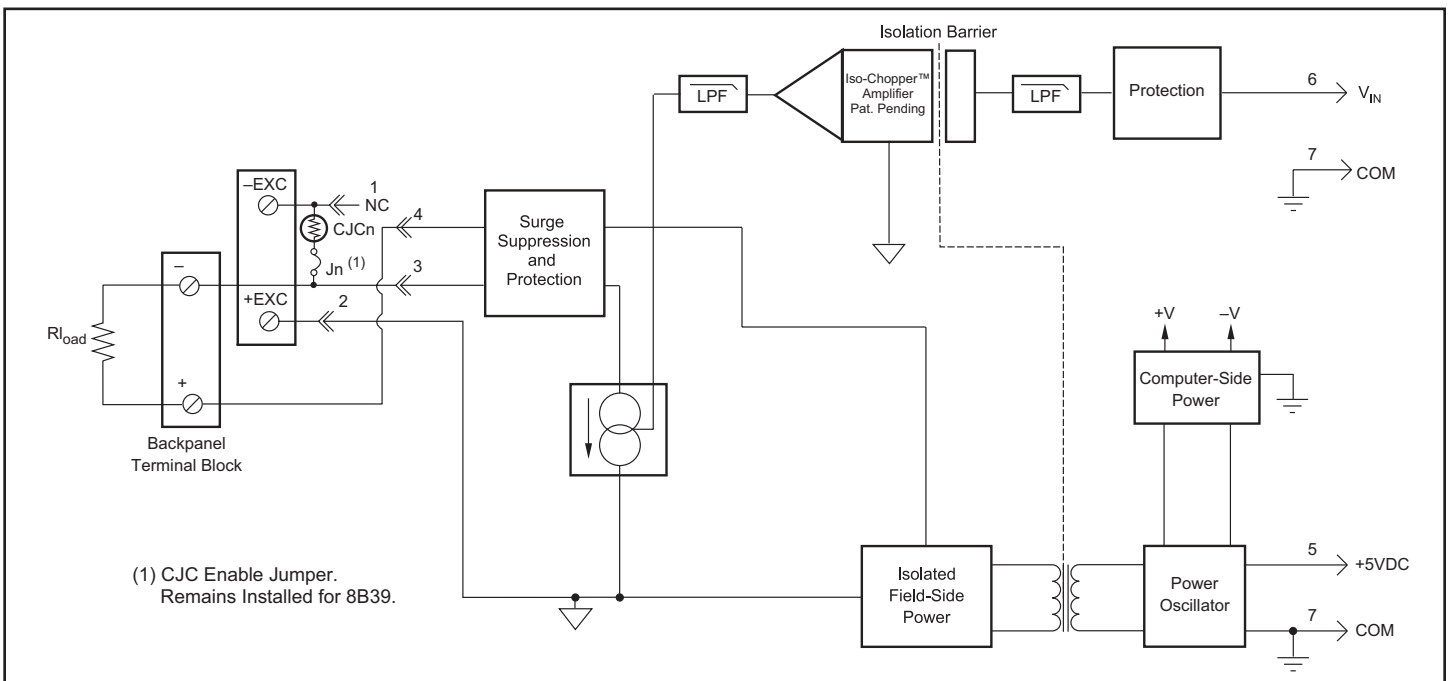

Figure 1: 8B39 Block Diagram

Specifications Typical* at T_A = +25°C and +5VDC power

Module	8B39-01,-02,-03,-04	8B39-07
Input Voltage Range	±5V or 0V to +5V	±5V
Input Voltage Maximum	±20V (no damage)	*
Input Resistance	50MΩ	*
Output Current Range	0 to 20mA or 4 to 20mA	±20mA
Over Range Capability	10%	*
Output Compliance Voltage (Open Circuit)	15VDC	±12VDC
Load Resistance Range	0 to 500Ω	0 to 400Ω
Output I Under Fault, max	26mA	±26mA
Output Protection		
Continuous	40VAC	*
Transient	ANSI/IEEE C37.90.1	*
CMV, Output to Input	1500Vrms max	*
Transient, Output to Input	ANSI/IEEE C37.90.1	*
CMR (50Hz or 60Hz)	110dB	*
NMR (-3dB at 100Hz)	60dB per Decade above 100Hz	*
Accuracy ⁽¹⁾	±0.05% Span	*
Linearity	±0.02% Span	*
Stability		
Offset	±10ppm/°C	*
Gain	±50ppm/°C	±100ppm/°C
Noise		
Output, 100kHz	2μArms	*
Bandwidth, -3dB	100Hz	*
Rise Time, 10 to 90% Span	5ms	*
Power Supply Voltage	+5VDC ±5%	*
Power Supply Current	100mA	*
Power Supply Sensitivity	±100ppm/%	*
Mechanical Dimensions (h)(w)(d)	1.11" x 1.65" x 0.40" (28.1mm x 41.9mm x 10.2mm)	*
Environmental		
Operating Temperature Range	-40°C to +85°C	*
Storage Temperature Range	-40°C to +85°C	*
Relative Humidity	0 to 95% Noncondensing	*
Emissions EN61000-6-4	ISM, Group 1	*
Radiated, Conducted	Class A	*
Immunity EN61000-6-2	ISM, Group 1	*
RF	Performance A ±0.5% Span Error	*
ESD, EFT	Performance B	*

NOTES:

*Contact factory or your local Dataforth sales office for maximum values.

* Same specification as -01, -02, -03, -04 models.

(1) Includes linearity, hysteresis and repeatability.

Ordering Information

Model	Input Range	Output Range
8B39-01	0V to +5V	4mA to 20mA
8B39-02	-5V to +5V	4mA to 20mA
8B39-03	0V to +5V	0mA to 20mA
8B39-04	-5V to +5V	0mA to 20mA
8B39-07	-5V to +5V	-20mA to +20mA

Installation Notes:

- 1.) This Equipment is Suitable for Use in Class I, Division 2, Groups A, B, C, D, or Non-Hazardous Locations Only.
- 2.) WARNING - Explosion Hazard - Substitution of Any Components May Impair Suitability for Class I, Division 2.
- 3.) WARNING - Explosion Hazard - Do Not Disconnect Equipment Unless Power Has Been Switched Off or The Area is Known to be Non-Hazardous.