

# OV9726 720p HD product brief



available in  
a lead-free  
package

## Native 720p/30 HD Video for Portable Applications

The OV9726 is a 1/6.5-inch native 720p/30 high-definition (HD) CMOS image sensor, designed specifically for ultra compact, high-performance HD cameras for portable electronics. The OV9726 uses OmniVision's proprietary 1.75-micron OmniBSI™ pixel architecture to achieve superior low-light sensitivity (1300 mV/lux-sec), reduced crosstalk and excellent quantum efficiency to ensure high color fidelity and image clarity. The sensor's short stack height of only 3.5 mm enables the smallest available camera modules in its class, making it an ideal choice for notebooks, netbooks, webcams, mobile phones, portable media players (PMPs) and other mobile entertainment devices.

OmniVision's native HD sensors offer the best available image quality and camera performance as they do not suffer from degradation or image artifacts due to scaling or cropping, which is typically used to achieve HD resolution from larger array sensors.

The OV9726 CMOS image sensor supports multiple platform architectures and controllers with both parallel and MIPI interfaces. It significantly reduces product development time by allowing system designers to leverage the same opto-electrical design across various products and multiple market segments.

Exposure control, white balance and defective pixel canceling are programmable through the SCCB interface. In addition, OmniVision image sensors use proprietary sensor technology to improve image quality by reducing or eliminating common lighting/electrical sources of image contamination, such as fixed pattern noise and smearing to produce a clean, fully stable color image.

Find out more at [www.ovt.com](http://www.ovt.com).

## Applications

- Cellular and Picture Phones
- Notebooks
- PC Multimedia
- Portable Media Players (PMP)
- Entertainment

## Product Features

- SMIA profile level 0 control
- MIPI and D-PHY specification (contains one clock lane and one data lane with a maximum of 600 Mbps data transfer rate)
- supports free-running clock and gated clock
- supports global analog gain
- high sensitivity and low dark current for low-light conditions
- low operating voltage and low power consumption for embedded portable applications
- supports down sample mode and VarioPixel®
- auto black level calibration
- defect correction capability
- CCI for flexible function control

# OV9726

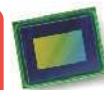

## Ordering Information

- OV09726-A40A (color, lead-free, 40-pin CSP3)
- OV09726-G04A (color, chip probing, 200 µm backgrinding, reconstructed wafer)

## Product Specifications

- active array size: 1280 x 800
- power supply:
  - core: 1.5 V
  - analog: 2.8 V (typical) or 3.3 V (optional)
  - I/O: 1.8 V (typical)
- temperature range:
  - operating: -30°C to 70°C
  - stable image: 0°C to 50°C
- output formats: 10-bit RAW RGB data
- lens size: 1/6.5"
- lens chief ray angle: 27° non-linear
- input clock frequency: 6 ~ 27 MHz
- S/N ratio: 37 dB
- dynamic range: 69 dB
- maximum image transfer rate: 30 fps
- sensitivity: 1300 mV/(lux-sec)
- scan mode: progressive
- maximum exposure interval: 824 x  $t_{ROW}$
- pixel size: 1.75 µm x 1.75 µm
- image area: 2300 µm x 1440 µm
- package/die dimensions:
  - CSP3: 4325 µm x 3515 µm
  - COB: 4340 µm x 3530 µm

## Functional Block Diagram

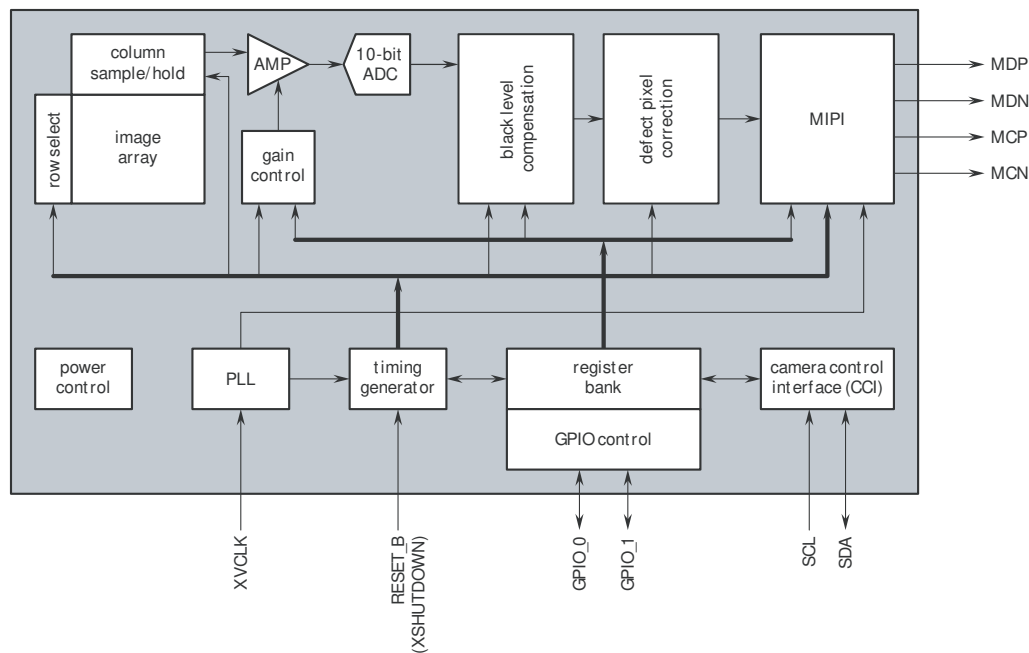

4275 Burton Drive  
Santa Clara, CA 95054  
USA

Tel: +1 408 567 3000  
Fax: +1 408 567 3001  
www.ovt.com

OmniVision reserves the right to make changes to their products or to discontinue any product or service without further notice. OmniVision is a registered trademark of OmniVision Technologies, Inc. The OmniVision logo and OmniBSI are trademarks of OmniVision Technologies, Inc. All other trademarks are the property of their respective owners.

