

Verpackt im Gurt in Anlehnung an DIN IEC 60286-3
 tape on reel packaging according to DIN IEC 60286-3
 Verpackungseinheit: 560 Stück
 packaging unit: 560 pcs

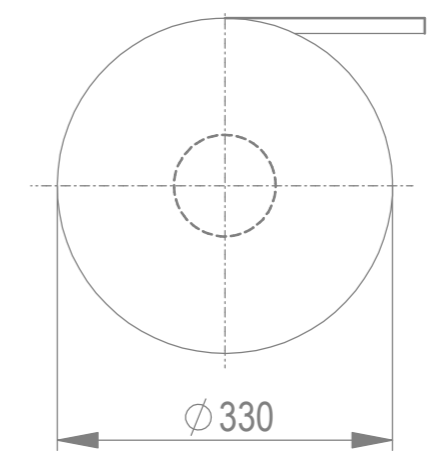

Abspulrichtung - reel off direction →

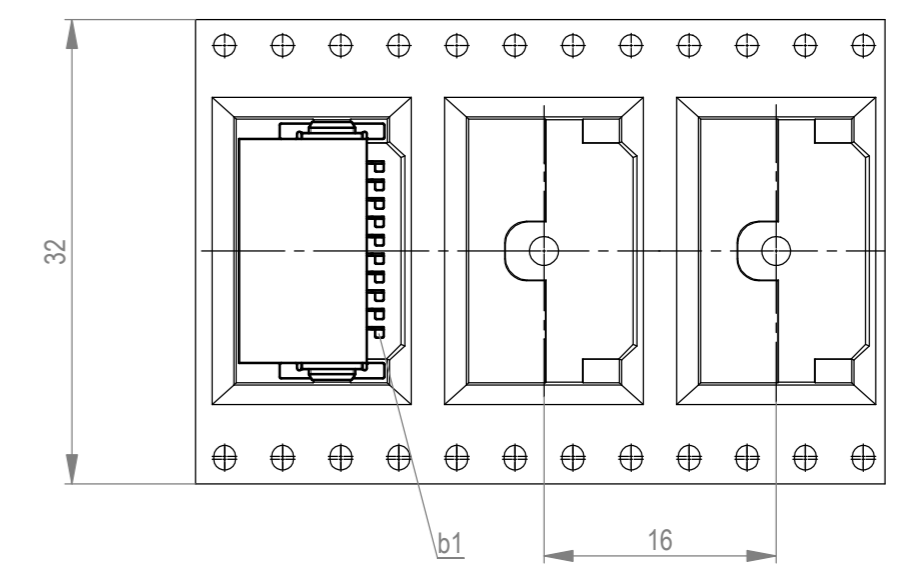

Leiterplatten-Layout Vorschlag für SMT
 PCB-Layout Proposal for SMT

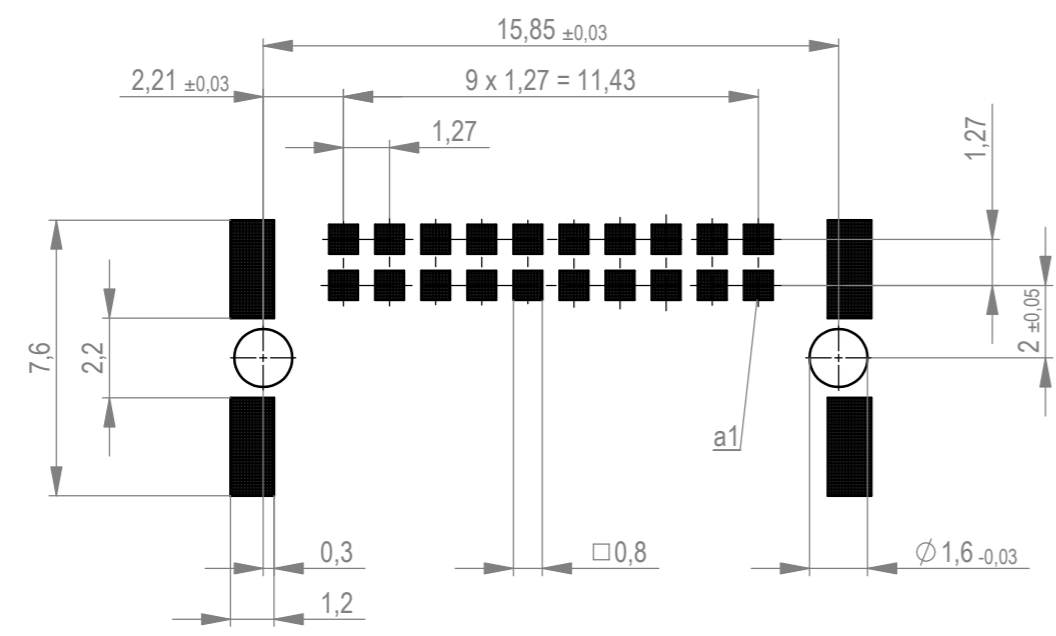

Anforderungsstufe 1
 performance level 1
 Kontaktbereich vergoldet
 mating area gold plating
 Anschlussbereich verzinkt 4-6 µm
 terminal area 4-6 µm tin plating
 Koplanarität der Anschlüsse ≤ 0,1 mm
 coplanarity area of termination ≤ 0,1 mm

BA7-03 - Standard Bauhöhe
 type7-03 - Standard Assembly Height

Dimension no.	Tolerances	Scale	5:1
	ISO 8015	Material	
Customer drawing:	Subject to modification without prior notice. Drawing will not be updated.		
All rights reserved. Only for information. To ensure that this is the latest version of this drawing, please contact one of the ERNI companies before using.	ERNI International AG Zürichstrasse 72 8306 Brüttisellen - Zürich Switzerland		Messerl. SMC-B 20-SMD-BA7-03 Male SMC-B 20-SMD-type7-03 354095 Class SMCB
Index	Date	12.02.2020	1 A2

Wichtigste Voraussetzung dieses Dokuments, Verwendung und Mitteilung dieses Dokuments sind die Rechte vorbehalten. Alle Rechte für den Fall der Patent-, Gebrauchsmarken- oder Geschäftsgeheimnisverletzung vorbehalten. The reproduction, distribution and alteration of this document as well as the communication of its content in any form or by any means is prohibited. All rights reserved in the event of the patent, utility model or design.