

SPECIFICATIONS

(RoHS Compliant)



Model Number: MD24B1
Part Number: 19028866A
SPEC Number: 26013793A01

April 8, 2013

Mechanical Drawing:

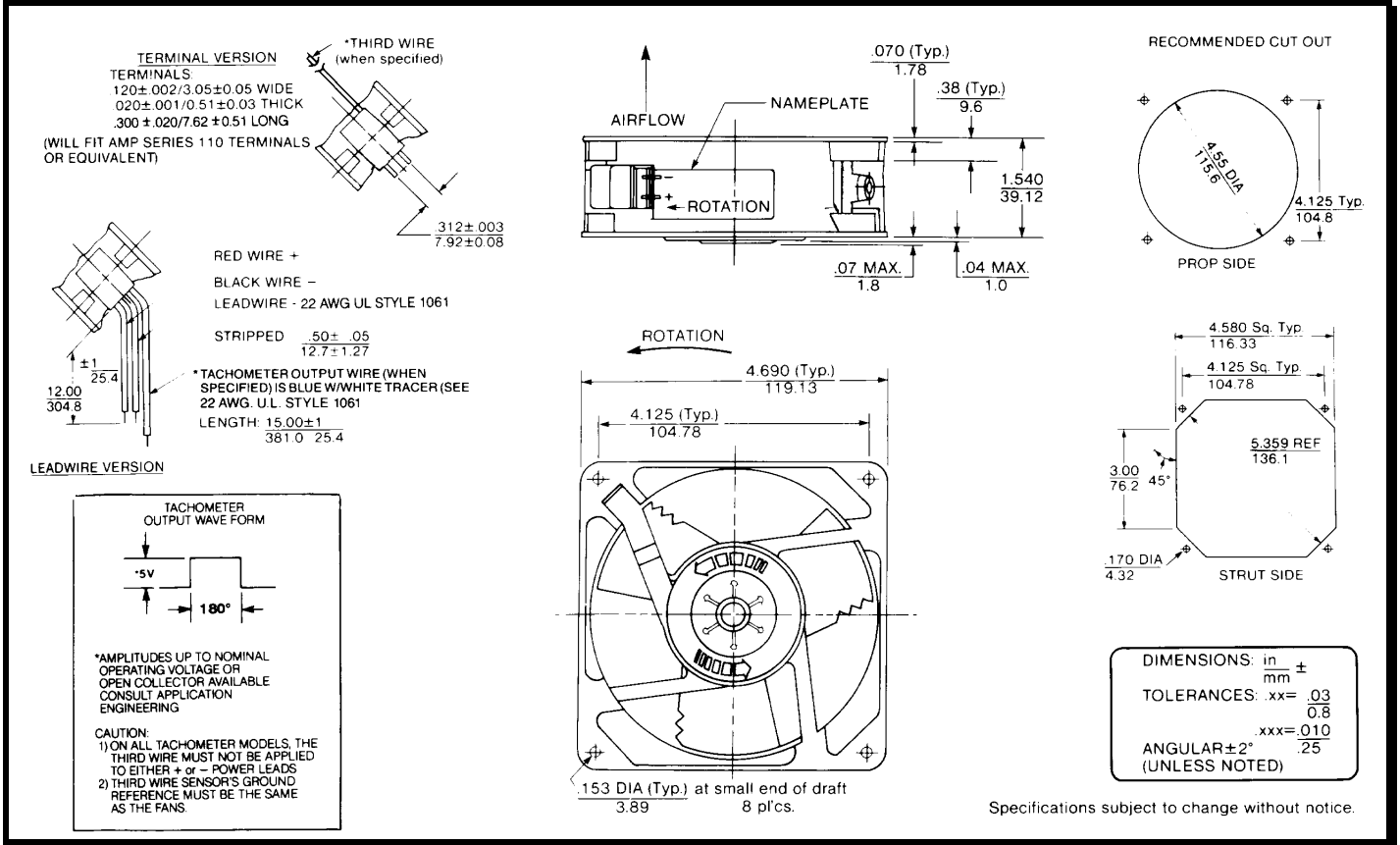

Motor:

Nominal Voltage = 24 vdc
 Operating Voltage Range = 12 - 28 vdc
 Running Current = 0.250 amps
 Locked Rotor Current = 0.750 amps
 Running Power = 6.0 watts
 Average Speed = 3100 rpm
 Bearings = Ball
 Air Flow = 110 CFM
 Acoustic: = 50.0 dBA

Construction:

Venturi: Die-Cast Zinc Alloy, Black
 Propeller: Plastic, Black, UL 94V-0

Life Expectancy:

This fan is designed for continuous duty life of 83,000 hours at 40°C.

Additional Features:

Brushless DC Motor
 Electronic Locked Rotor Protection
 Automatic Restart Capability
 Polarity Protected
 Operating Temperature: -10°C to 70°C
 Storage Temperature: -40°C to 85°C
 Airflow from strut to propeller

Termination:

12" Lead wires, 22 AWG, UL 1061
 Red = Fan Power (+)
 Black = Fan Ground (-)

Agency Approvals:

UL, CE