

LOC	DIST	REVISIONS				
P	LTR	DESCRIPTION	DATE	DWN	APVD	
	E	UPDATED PART REVISION	12AUG2014	KR	JC	
	F	UPDATED PART REVISION	18AUG2014	KR	JC	
	G	ECR-15-009919 AND ECR-15-010559	15JUL2015	RS	JL	
	GI	REVISED NOTE 2	05FEB2021	MZ	MZ	

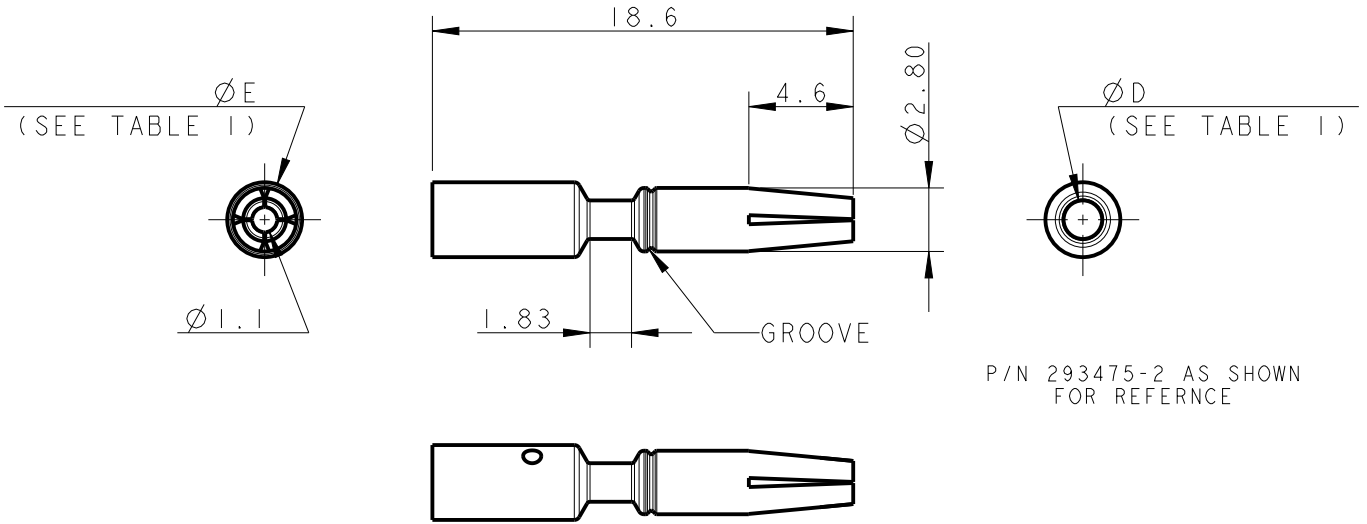

P/N 293475-2 AS SHOWN FOR REFERENCE

NOTES:

1) PACKAGING: SEE TE PACKAGING SPEC. 107-20294

2) PART NOT YET RELEASED FOR PRODUCTION. PART IS UNDER TEST TESTING AND NOT YET SUBMITTED TO AGENCY QUALIFICATION

TABLE 2 (SCALE 1:1)		
		2-293475-2
		1-293475-2
		293475-2
ADDITIONAL VIEWS, FOR REFERENCE	3D VIEWS FOR REFERENCE	PART NUMBER

TABLE 1							
2	4.0	3.9	2.8	0	~0.8	MACHINE SOCKET CONTACT NECTOR* M-LINE	2-293475-2
	2.5	3.3	2.2	0	~0.6	MACHINE SOCKET CONTACT NECTOR* M-LINE	1-293475-2
	1.5	3.3	1.7	1	~0.7	MACHINE SOCKET CONTACT NECTOR* M-LINE	293475-2
NOTE	CROSS SECTION (mm ²)	NOM. DIM. "E"	NOM. DIM. "D"	NO. OF GROOVES	NET WEIGHT (g)	DESCRIPTION	PART NUMBER

THIS DRAWING IS UNPUBLISHED. BY - ALL RIGHTS RESERVED. COPYRIGHT 2010

DIMENSIONS: mm	DWN M. ZUCCA 23OCT2009	MATERIAL BRASS	FINISH TIN PLTD
TOLERANCES UNLESS OTHERWISE SPECIFIED:	CHK M. ZUCCA 23OCT2009	TE Connectivity	
0 PLC ±-	APVD G. TURCO 23OCT2009		
1 PLC ±0.3	PRODUCT SPEC 108-20304	NAME MACHINED SOCKET CONTACT NECTOR* M-LINE	
2 PLC ±0.20	APPLICATION SPEC 114-20152	SIZE A4	CAGE CODE 00779
3 PLC ±-	WEIGHT SEE TABLE 1	DRAWING NO	G=293475
4 PLC ±-	Customer Drawing	RESTRICTED TO	-
ANGLES ±3°		SCALE 3:1	SHEET 1 OF 1
		REV	GI