

REV.	DESCRIPTION	DATE	APPROVED
A	Engineering Release	03/10/04	M. C.

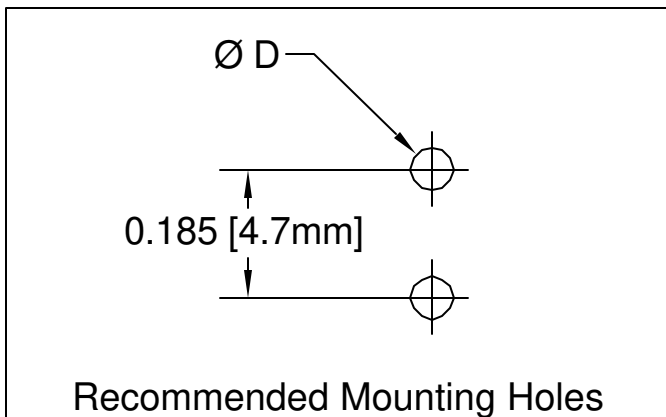
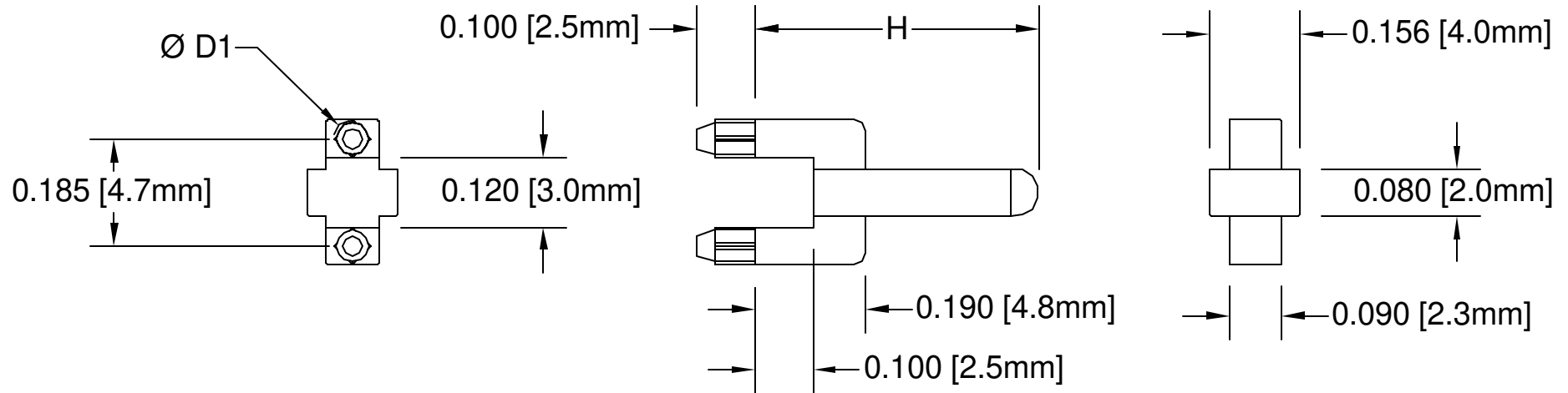

P/N	H	$\varnothing D$ $\begin{smallmatrix} +.003 \\ -.002 \end{smallmatrix}$	$\varnothing D1$
VLPR-24-500-2	0.500"(12.7mm)	.062"(1.6mm)	.065"(1.7mm)
VLPR-24-650-2	0.650"(16.5mm)	.062"(1.6mm)	.065"(1.7mm)
VLPR-24-858-2	0.858"(21.8mm)	.058"(1.5mm)	.060"(1.5mm)
VLPR-24-1028-2	1.028"(26.1mm)	.058"(1.5mm)	.060"(1.5mm)

2. MATERIAL: POLYCARBONATE 94V-0 CLEAR, BIVAR MATERIAL CODE 47-CR.
SAMYANG CORPORATION POLYCARBONATE 3025N2 CLEAR
1. GENERAL SPECIFICATIONS: BIVAR MOLDED COMPONENT SPECIFICATION BV00-E101.

STANDARD TOLERANCE (UNLESS OTHERWISE SPECIFIED)		BIVAR®	
DECIMALS	ANGULAR	4 THOMAS, IRVINE, CA 92618 TEL: (949) 951-8808 FAX: (949) 951-3974	
.X ±.1	X° ± 1°	TITLE: VERTICAL LIGHT PIPE	
.XX ±.01		DESIGNED: T. Yin	DATE: 03/10/04
.XXX ±.005		CHECKED: D. Green	DATE: 03/10/04
		PART NO: VLPR-24-XXXX-2	REVISION: A
		CAGE CODE : 32559	SHEET # 1 OF 1