

- **Designed for SDARS IF Receiver**
- **Low Insertion Loss**
- **5.0 X 7.0 mm Surface-Mount Case**
- **Differential Input and Output**
- **Complies with Directive 2002/95/EC (RoHS)**
- **Moisture Sensitivity Level: 1**
- **AEC-Q200 Qualified**

**SF1141B-4**

**75.00 MHz  
SAW Filter**

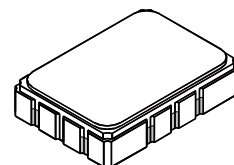

**SMP-03-S**

**Absolute Maximum Ratings**

Rating	Value	Units
Maximum Incident Power in Passband	+10	dBm
Max. DC voltage between any 2 terminals	30	VDC
Storage Temperature Range	-40 to +85	°C
Max Soldering Profile	265°C for 10 s	

**Electrical Characteristics**

Characteristic	Sym	Notes	Min	Typ	Max	Units
Nominal Center Frequency	$f_C$		75.000			MHz
Passband	Insertion Loss at $f_C$	IL		12.5	16.0	dB
		1dB Passband	$BW_1$	$\pm 6.35$	$\pm 7.43$	MHz
	Fast Amplitude Ripple over $f_C \pm 6.35$ MHz				1.5	dB <sub>P-P</sub>
	Group Delay Variation over $f_C \pm 6.35$ MHz	GDV		75	200	ns <sub>P-P</sub>
Rejection	$f_C - 100$ to $f_C - 18.8$ MHz		40	45		dB
		$f_C - 18.8$ to $f_C - 10.95$ MHz	37	45		
		$f_C + 10.95$ to $f_C + 18.8$ MHz	30	36		
		$f_C + 18.8$ to $f_C + 100$ MHz	40	45		
Operating Temperature Range	$T_A$		-40		+85	°C
Differential Input and Output Impedance	250 ohms					
Case Style	SMP-03-S 7 x 5 mm Nominal Footprint					
Lid Symbolization (YY=year, WW=week, S=shift, ## = Sequence Code)	RFM , SF1141B-4, <u>YYWWS##</u>					

**Electrical Connections**

Connection	Port 1 Hot	Port 1 Ground Return or Hot	Port 2 Hot	Port 2 Ground Return or Hot	Case Ground
<b>Terminals</b>	10	1	5	6	All Others

 **CAUTION: Electrostatic Sensitive Device. Observe precautions for handling.**

**NOTES:**

1. The design, manufacturing process, and specifications of this device are subject to change.
2. US or International patents may apply.
3. RoHS compliant from the first date of manufacture.

## Tape and Reel Specifications

Tape and Reel Standard per ANSI/EIA-481

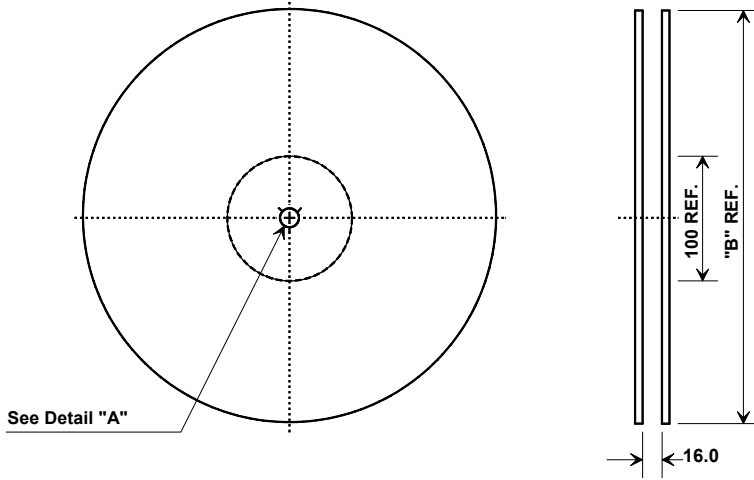

"B" Nominal Size		Quantity Per Reel
Inches	millimeters	
7	178	500
13	330	2000

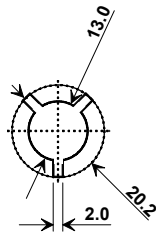

### COMPONENT ORIENTATION and DIMENSIONS

Carrier Tape Dimensions		Tolerance
Ao	5.5 mm	± 0.1mm
Bo	7.5 mm	± 0.1mm
Ko	2.0 mm	± 0.1mm
Pitch	8.0 mm	± 0.1mm
W	16.0 mm	± 0.2mm

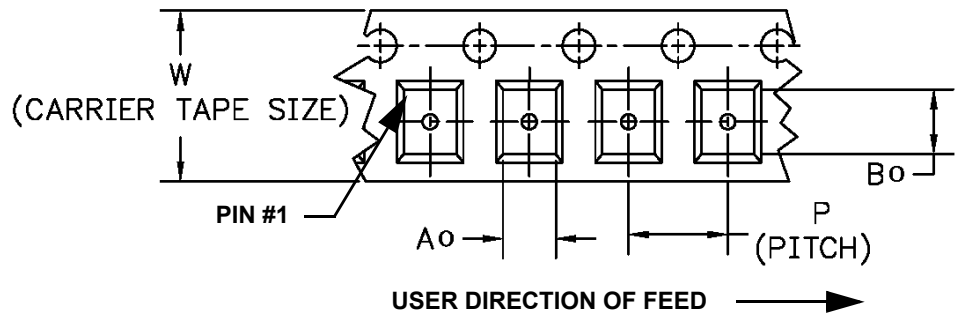
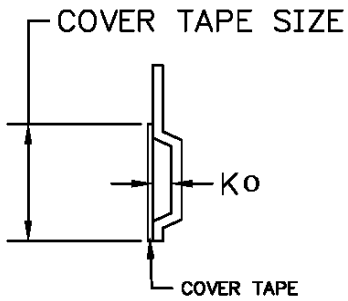

# SMP-03-S Case

## 12-Terminal Ceramic Surface-Mount Case

### 5 x 7 mm Nominal Footprint

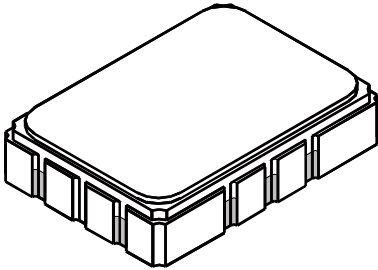

Case Dimensions						
Dimension	mm			Inches		
	Min	Nom	Max	Min	Nom	Max
A	6.80	7.00	7.20	0.268	0.276	0.283
B	4.80	5.00	5.20	0.189	0.197	0.205
C		1.65	2.00		0.065	0.079
D		0.80				
E	2.41	2.54	2.67	0.095	0.100	0.105
H	0.87	1.1	1.13	0.034	0.039	0.044
J		2.54				
K	2.87	3.00	3.13	0.113	0.118	0.123
P	1.14	1.27	1.40	0.045	0.050	0.055

Materials	
Solder Pad Termination	Au plating 30 - 60 μinches (76.2-152 μm) over 80-200 μinches (203-508 μm) Ni.
Lid	Fe-Ni-Co Alloy Electroless Nickel Plate (8-11% Phosphorus) 100-200 μinches Thick
Body	Al <sub>2</sub> O <sub>3</sub> Ceramic

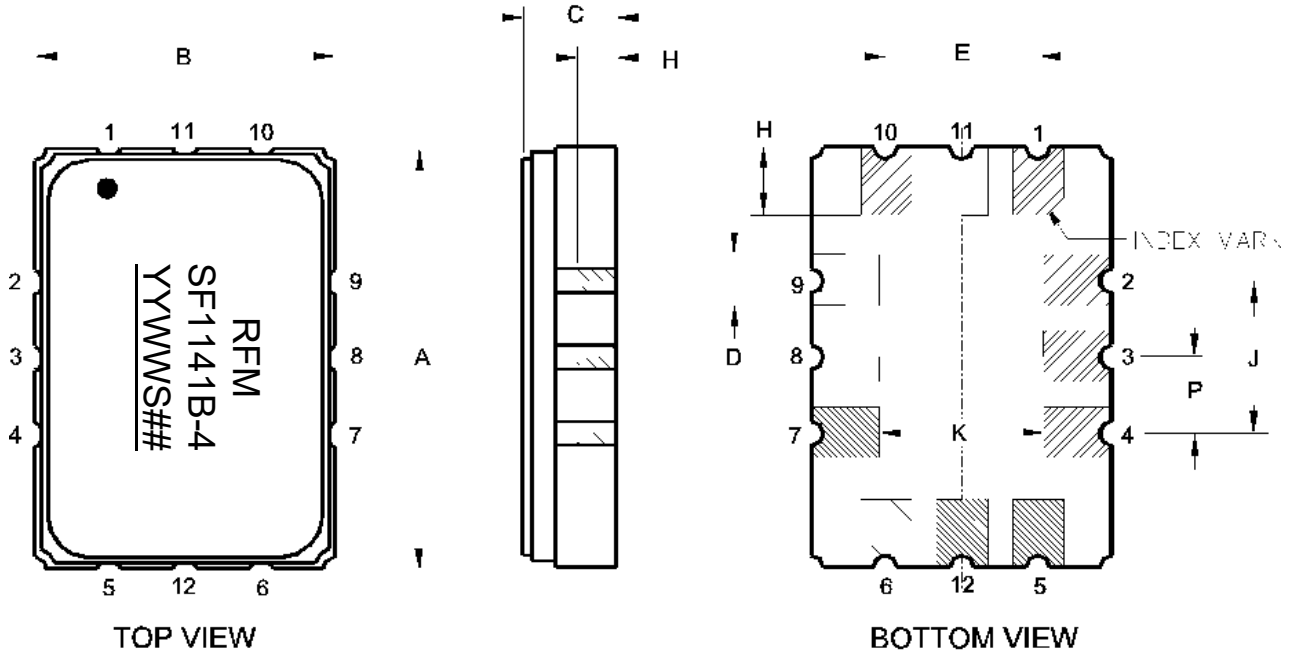

## Recommended Reflow Profile

1. Preheating shall be fixed at 150~180°C for 60~90 seconds.
2. Ascending time to preheating temperature 150°C shall be 30 seconds min.
3. Heating shall be fixed at 220°C for 50~80 seconds and at 260°C+0/-5°C peak (10 seconds).
4. Time: 5 times maximum.

