

CDBMT120-HF Thru. CDBMT1150-HF

Reverse Voltage: 20 to 150 Volts

Forward Current: 1.0 Amp

RoHS Device

Halogen Free

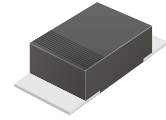

Features

- Excellent power dissipation offers better reverse leakage current and thermal resistance.
- Low profile package is 40% thinner than standards SOD-123.
- Low power loss,high efficiency.
- High current capability,low forward voltage drop.
- High surge capability.
- Guarding for overvoltage protection.
- Ultra high-speed switching.
- Silicon epitaxial planar chip,metal silicon junction.
- Lead-free part meets environmental standards of MIL-STD-19500/228

Mechanical data

- Epoxy: UL94-V0 rated flame retardant.
- Case: Molded plastic, SOD-123H/MINI SMA
- Terminals: Solderable per MIL-STD-750, method 2026.
- Polarity: Indicated by cathode band.
- Mounting Position: any
- Weight: 0.011 grams approx.

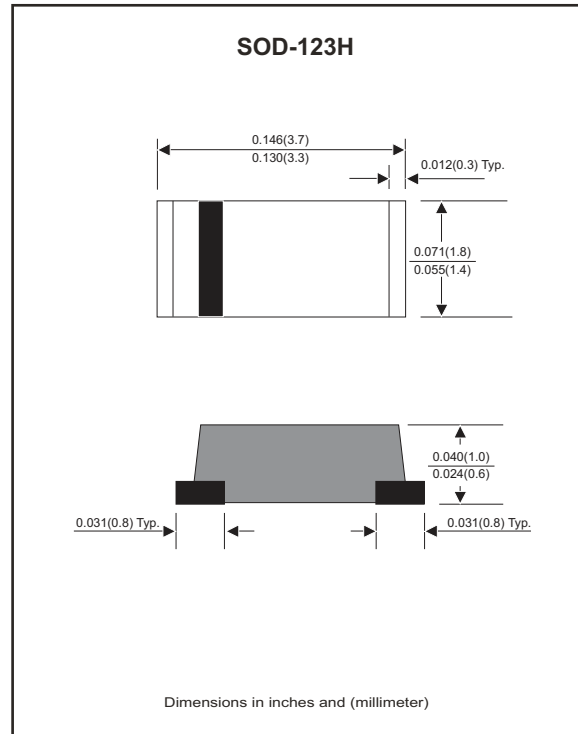

Maximum Ratings (at T_A=25 °C unless otherwise noted)

Parameter	Symbol	CDBMT 120-HF	CDBMT 130-HF	CDBMT 140-HF	CDBMT 150-HF	CDBMT 160-HF	CDBMT 180-HF	CDBMT 1100-HF	CDBMT 1150-HF	Unit	
Repetitive peak reverse voltage	V _{RRM}	20	30	40	50	60	80	100	150	V	
Continuous reverse voltage	V _R	20	30	40	50	60	80	100	150	V	
RMS voltage	V _{RMS}	14	21	28	35	42	56	70	105	V	
Forward rectified current	I _O	1.0								A	
Maximum forward voltage @ I _F =1.0A	V _F	0.50			0.70		0.85		0.92	V	
Max. Forward surge current 8.3ms single half sine-wave superimposed on rated load (JEDEC method)	I _{FSM}	25								A	
Max.Reverse current	V _R =V _{RRM} T _J =25°C	0.5								mA	
	V _R =V _{RRM} T _J =100°C	10									
Typ. Thermal resistance (Junction to ambient)	R _{θJA}	98								°C/W	
Typ. Diode Junction capacitance (Note 1)	C _J	120								pF	
Operating temperature	T _J	-55 to +125				-55 to +150					°C
Storage temperature range	T _{STG}	-65 to +175									°C

Note : 1. F=1MHz and applied 4V DC reverse voltage

Rating and Characteristic Curves (CDBMT120-HF Thru. CDBMT1150-HF)

Fig.1- Typical Forward Current Derating Curve

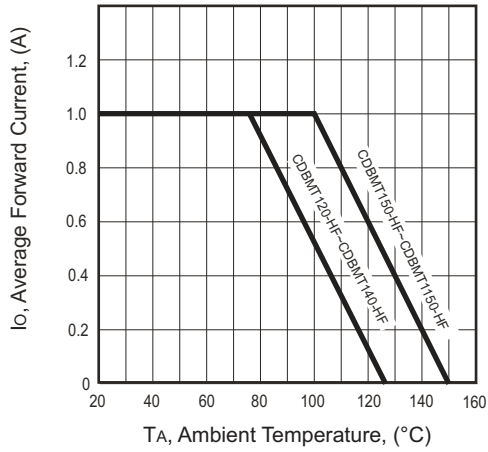

Fig.2 - Typical Forward Characteristics

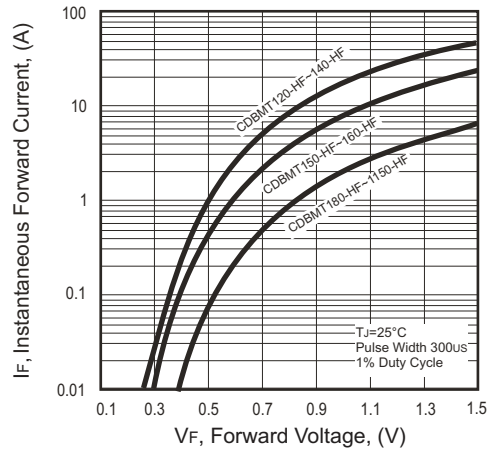

Fig.3 - Maximum Non-repetitive Forward Surge Current

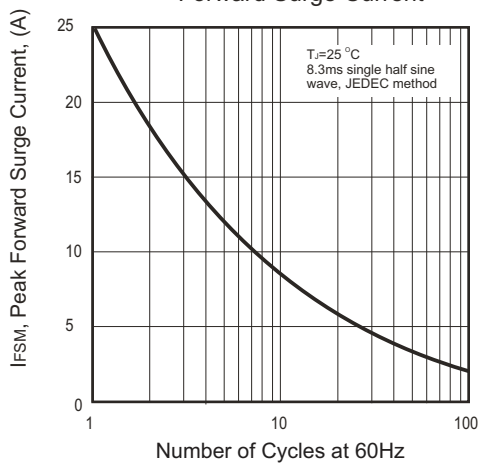

Fig.4 - Typical Junction Capacitance

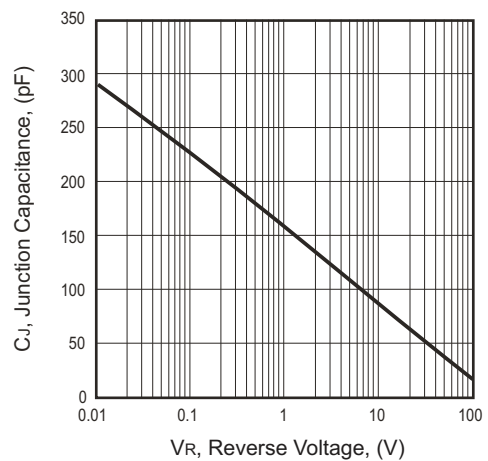
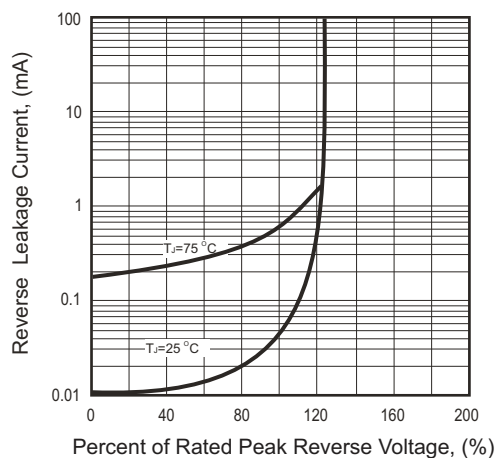
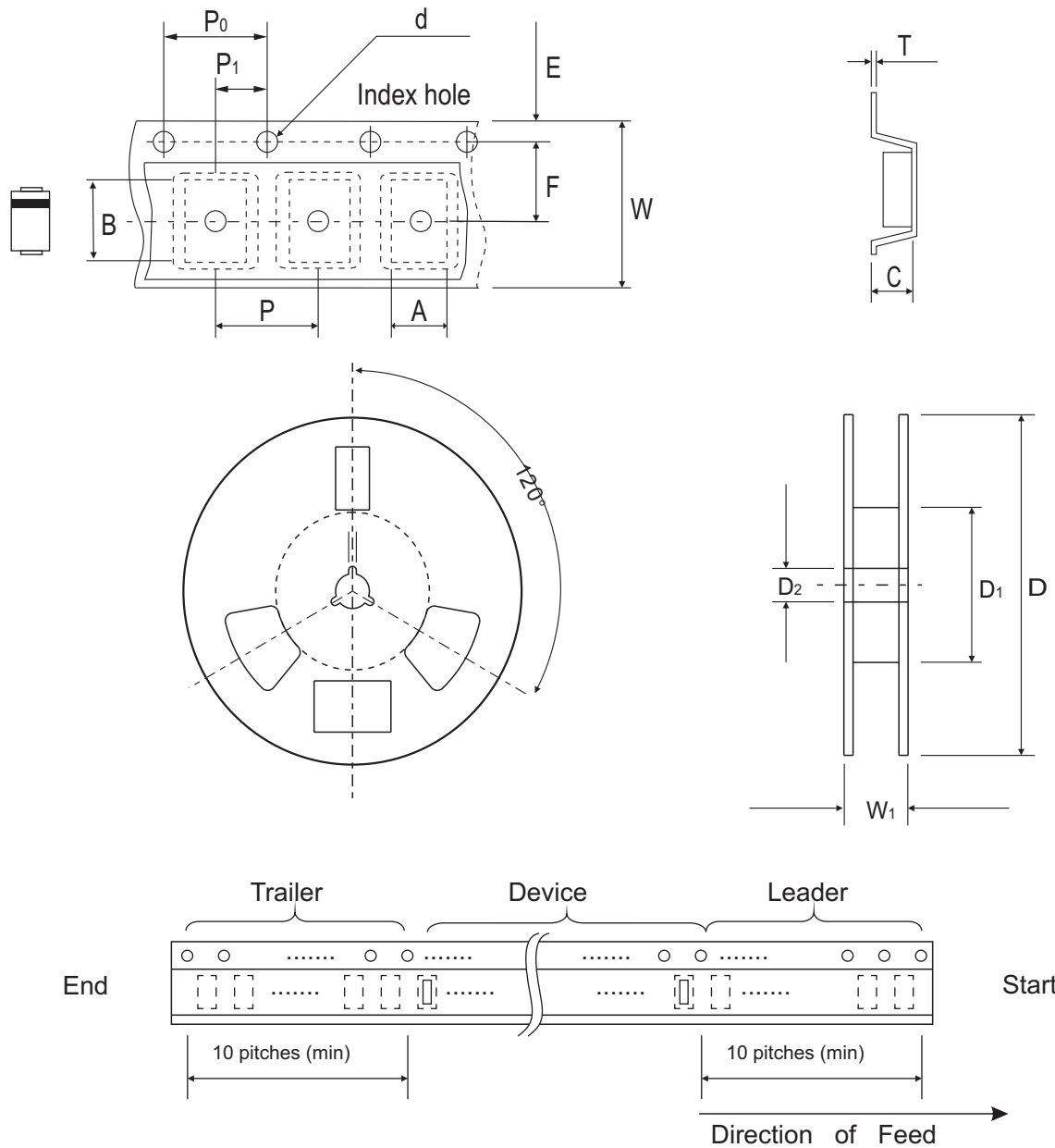

Fig.5 - Typical Reverse Characteristics



Reel Taping Specification



SOD-123H	SYMBOL	A	B	C	d	D	D1	D2
	(mm)	2.00 ± 0.10	3.85 ± 0.10	1.10 ± 0.10	1.50 ± 0.10	178 ± 2.00	62.0 MIN.	13.0 ± 0.50
	(inch)	0.079 ± 0.004	0.152 ± 0.004	0.043 ± 0.004	0.059 ± 0.004	7.00 ± 0.079	2.440 MIN.	0.512 ± 0.020

SOD-123H	SYMBOL	E	F	P	P0	P1	T	W	W1
	(mm)	1.75 ± 0.10	3.50 ± 0.10	4.00 ± 0.10	4.00 ± 0.10	2.00 ± 0.10	0.23 ± 0.10	8.00 ± 0.30	11.40 ± 1.0
	(inch)	0.069 ± 0.004	0.138 ± 0.004	0.157 ± 0.004	0.157 ± 0.004	0.079 ± 0.004	0.009 ± 0.004	0.315 ± 0.012	0.449 ± 0.039

Pinning information

Pin	Simplified outline	Symbol
PIN 1 Cathode PIN 2 Anode		

Marking Code

Part Number	Marking Code
CDBMT120-HF	12
CDBMT130-HF	13
CDBMT140-HF	14
CDBMT150-HF	15
CDBMT160-HF	16
CDBMT180-HF	18
CDBMT1100-HF	10
CDBMT1150-HF	115



xx / xxx = Product type marking code

Suggested PAD Layout

SIZE	SOD-123H	
	(mm)	(inch)
A	3.00	0.118
B	1.30	0.051
C	1.80	0.071
D	4.30	0.169
E	1.70	0.067

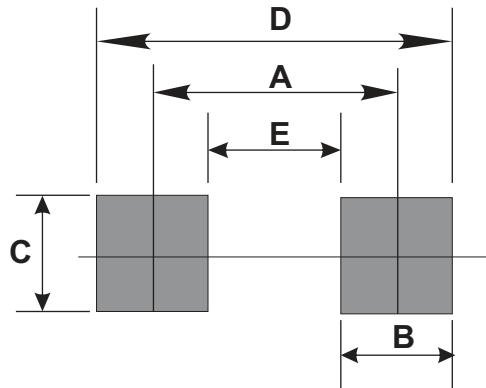

Standard Packaging

Case Type	REEL PACK	
	REEL (pcs)	Reel Size (inch)
SOD-123H	3,000	7