

Product Document

TSL1401CCS

128 × 1 Linear Sensor Array With Hold

General Description

The TSL1401CCS linear sensor array consists of a 128 × 1 array of photodiodes, associated charge amplifier circuitry, and a pixel data-hold function that provides simultaneous-integration start and stop times for all pixels. The pixels measure 63.5µm (H) by 55.5µm (W) with 63.5µm center-to-center spacing and 8µm spacing between pixels. Operation is simplified by internal control logic that requires only a serial-input (SI) signal and a clock.

Ordering Information and Content Guide appear at end of datasheet.

Key Benefits & Features

The benefits and features of the TSL1401CCS linear sensor array, are listed below:

Figure 1:
Added Value of Using TSL1401CCS

Benefits	Features
<ul style="list-style-type: none"> Enables High-Resolution Edge Detection 	<ul style="list-style-type: none"> 128 × 1 Sensor-Element Organization
<ul style="list-style-type: none"> Supports High Resolution OCR, Bar Code Reading 	<ul style="list-style-type: none"> 400 Dots-Per-Inch (DPI) Sensor Pitch
<ul style="list-style-type: none"> Facilitates Grey Scale Scanning and Accurate Positioning 	<ul style="list-style-type: none"> High Linearity and Uniformity
<ul style="list-style-type: none"> Usable Over a Wide Range of Light Levels 	<ul style="list-style-type: none"> Wide Dynamic Range... 4000:1 (72dB)
<ul style="list-style-type: none"> Simplifies ADC Interface 	<ul style="list-style-type: none"> Output Referenced to Ground
<ul style="list-style-type: none"> Minimal Smearing of Moving Images 	<ul style="list-style-type: none"> Low Image Lag... 0.5% Typ
<ul style="list-style-type: none"> Allows High Scan Rate for Faster Throughput 	<ul style="list-style-type: none"> Operation to 8MHz
<ul style="list-style-type: none"> No Special Power Supply Required 	<ul style="list-style-type: none"> Single 3V to 5V Supply
<ul style="list-style-type: none"> Utilizes Full ADC Input Range 	<ul style="list-style-type: none"> Rail-to-Rail Output Swing
<ul style="list-style-type: none"> Minimizes Component Count 	<ul style="list-style-type: none"> No External Load Resistor Required
<ul style="list-style-type: none"> Small Form Factor and Footprint 	<ul style="list-style-type: none"> Available in a Solder-Bump Linear Array Package
<ul style="list-style-type: none"> Compatible With Most Process Flows 	<ul style="list-style-type: none"> Lead (Pb) Free and RoHS Compliant

Applications

The TSL1401CCS is intended for use in a wide variety of applications, including:

- Image Scanning
- Mark and Code Reading
- Optical Character Recognition (OCR) and Contact Imaging
- Edge Detection and Positioning
- Optical Linear and Rotary Encoding

Block Diagram

The functional blocks of this device are shown below:

Figure 2:
TSL1401CCS Block Diagram

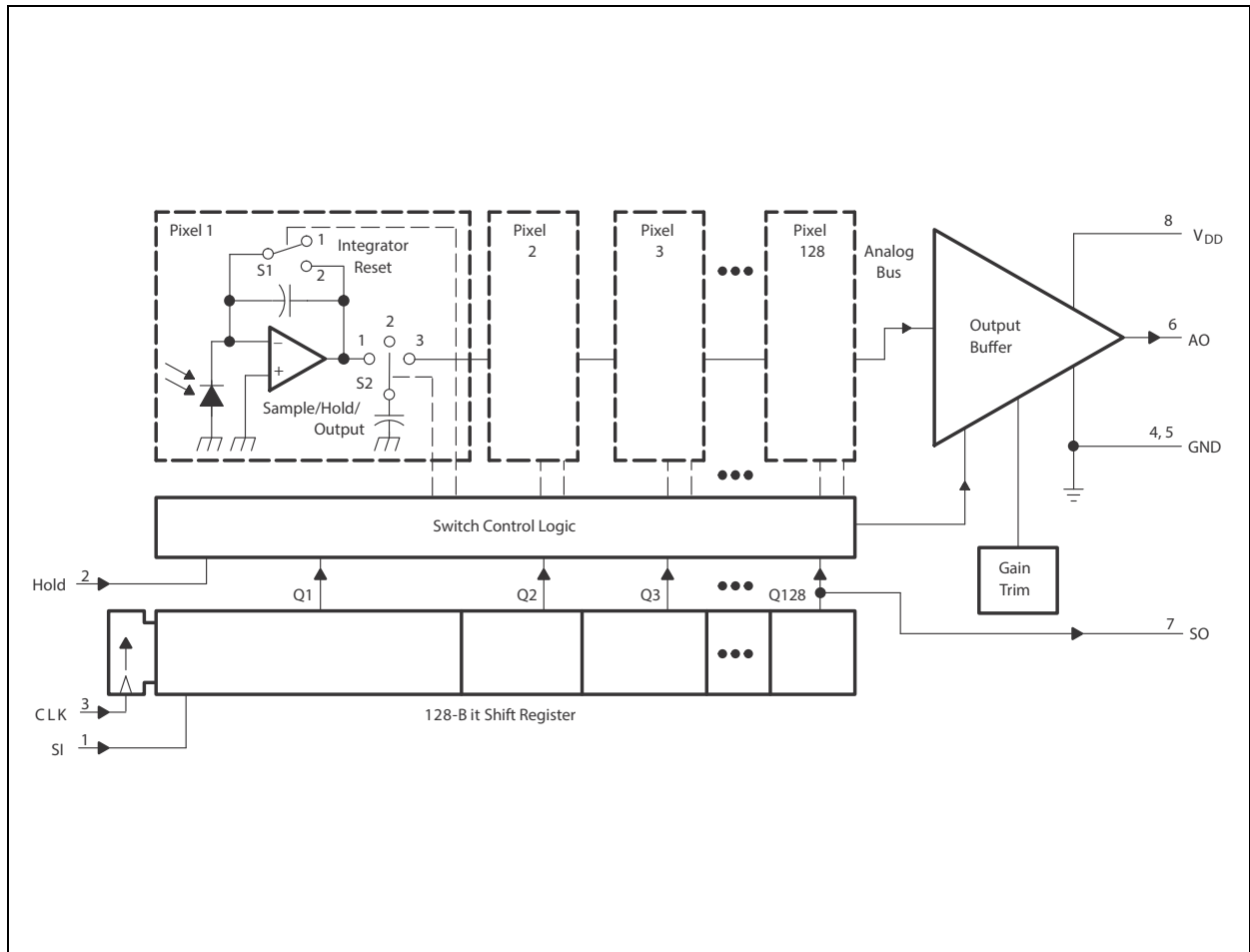

Detailed Description

The sensor consists of 128 photodiodes arranged in a linear array. Light energy impinging on a photodiode generates photocurrent, which is integrated by the active integration circuitry associated with that pixel.

During the integration period, a sampling capacitor connects to the output of the integrator through an analog switch. The amount of charge accumulated at each pixel is directly proportional to the light intensity and the integration time.

The output and reset of the integrators is controlled by a 128-bit shift register and reset logic. An output cycle is initiated by clocking in a logic 1 on SI. For proper operation, after meeting the minimum hold time condition, SI must go low before the next rising edge of the clock. The signal called Hold is normally connected to SI. Then, the rising edge of SI causes a HOLD condition. This causes all 128 sampling capacitors to be disconnected from their respective integrators and starts an integrator reset period. As the SI pulse is clocked through the shift register, the charge stored on the sampling capacitors is sequentially connected to a charge-coupled output amplifier that generates a voltage on analog output AO. Simultaneously, during the first 18 clock cycles, all pixel integrators are reset, and the next integration cycle begins on the 19th clock. On the 129th clock rising edge, the SI pulse is clocked out of the shift register and the analog output AO assumes a high impedance state. Note that this 129th clock pulse is required to terminate the output of the 128th pixel, and return the internal logic to a known state. If a minimum integration time is desired, the next SI pulse may be presented after a minimum delay of t_{qt} (pixel charge transfer time) after the 129th clock pulse.

AO is an op amp-type output that does not require an external pull-down resistor. This design allows a rail-to-rail output voltage swing. With $V_{DD} = 5V$, the output is nominally 0V for no light input, 2V for normal white level, and 4.8V for saturation light level. When the device is not in the output phase, AO is in a high-impedance state.

The voltage developed at analog output (AO) is given by:

$$(EQ1) \quad V_{out} = V_{drk} + (R_e) (E_e) (t_{int})$$

where:

- V_{out} is the analog output voltage for white condition
- V_{drk} is the analog output voltage for dark condition
- R_e is the device responsivity for a given wavelength of light given in $V/(\mu J/cm^2)$
- E_e is the incident irradiance in $\mu W/cm^2$
- t_{int} is integration time in seconds

A 0.1 μF bypass capacitor should be connected between V_{DD} and ground as close as possible to the device.

The TSL1401CCS is intended for use in a wide variety of applications, including: image scanning, mark and code reading, optical character recognition (OCR) and contact imaging, edge detection and positioning, and optical linear and rotary encoding.

Pin Assignments

The TSL1401CCS pin assignments are described below:

Figure 3:
Pin Diagram (Top View)

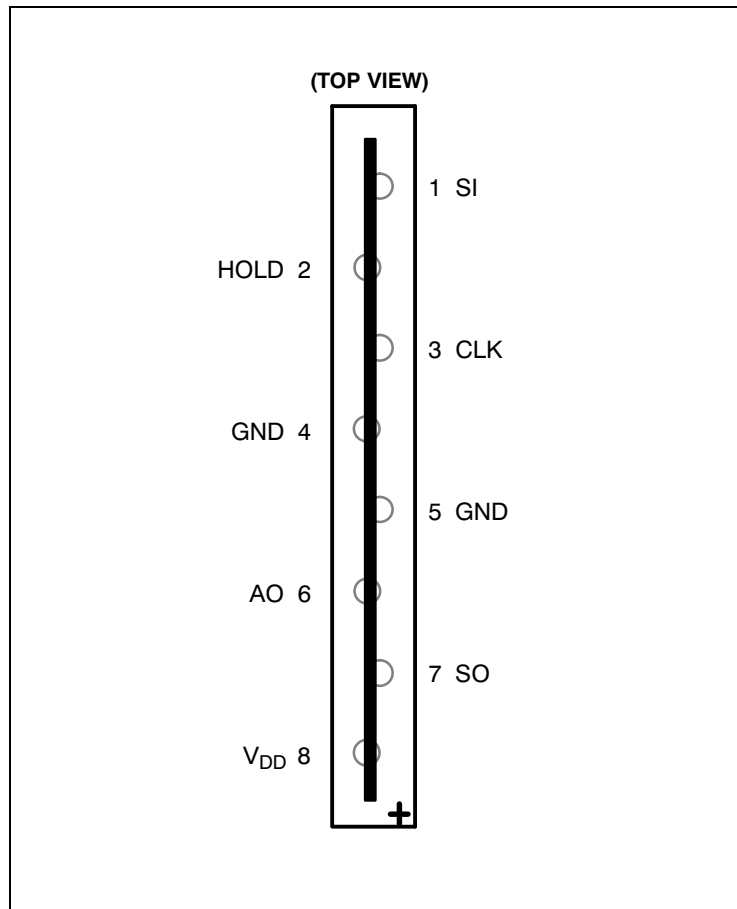

Figure 4:
Terminal Functions

Terminal		Description
Name	No.	
SI	1	Serial input. SI defines the start of the data-out sequence.
HOLD	2	Hold signal. HOLD freezes the result of a 128 pixel scan.
CLK	3	Clock. The clock controls charge transfer, pixel output, and reset.
GND	4, 5	Ground (substrate). All voltages are referenced to the substrate.
AO	6	Analog output
SO	7	Serial output. SO provides a signal to drive the SI input of another device for cascading or as an end-of-data indication.
V _{DD}	8	Supply voltage. Supply voltage for both analog and digital circuits.

Absolute Maximum Ratings

Stresses beyond those listed under [Absolute Maximum Ratings](#) may cause permanent damage to the device. These are stress ratings only. Functional operation of the device at these or any other conditions beyond those indicated under [Electrical Characteristics](#) is not implied. Exposure to absolute maximum rating conditions for extended periods may affect device reliability.

Figure 5:
Absolute Maximum Ratings

Symbol	Parameter	Min	Max	Unit
V_{DD}	Supply voltage range	-0.3	6	V
V_I	Input voltage range	-0.3	$V_{DD} + 0.3$	V
I_{IK}	Input clamp current, ($V_I < 0$) or ($V_I > V_{DD}$)	-20	20	mA
I_{OK}	Output clamp current, ($V_O < 0$) or ($V_O > V_{DD}$)	-25	25	mA
V_O	Voltage range applied to any output in the high impedance or power OFF state	-0.3	$V_{DD} + 0.3$	V
I_O	Continuous output current, ($V_O = 0$ to V_{DD})	-25	25	mA
	Continuous current through V_{DD} or GND	-40	40	mA
I_O	Analog output current range	-25	25	mA
	Maximum light exposure at 638nm		5	mJ/cm ²
T_A	Operating free-air temperature range	-40	100	°C
T_{stg}	Storage temperature range	-40	100	°C
	Solder reflow temperature, case exposed for 10 seconds		260	°C

Electrical Characteristics

All limits are guaranteed. The parameters with min and max values are guaranteed with production tests or SQC (Statistical Quality Control) methods.

Figure 6:
Recommended Operating Conditions (see Figure 10 and Figure 11)

Symbol	Parameter	Min	Nom	Max	Unit
V_{DD}	Supply voltage	3	5	5.5	V
V_I	Input voltage	0		V_{DD}	V
V_{IH}	High-level input voltage	2		V_{DD}	V
V_{IL}	Low-level input voltage	0		0.8	V
λ	Wavelength of light source	400		1000	nm
f_{clock}	Clock frequency	5		8000	kHz
t_{int}	Sensor integration time ⁽¹⁾	0.03375		100	ms
$t_{su(SI)}$	Setup time, serial input	20			ns
$t_{h(SI)}$	Hold time, serial input ⁽²⁾	0			ns
T_A	Operating free-air temperature	-40		85	°C

Note(s):

1. Integration time is calculated as follows:

$$t_{int(min)} = (128 - 18) \text{ clock period} + 20\mu\text{s}$$

where 128 is the number of pixels in series, 18 is the required logic setup clocks, and 20μs is the pixel charge transfer time (t_{qt})

2. SI must go low before the rising edge of the next clock pulse.

Figure 7:

Electrical Characteristics at $f_{clock} = 1\text{MHz}$, $V_{DD} = 5\text{V}$, $T_A = 25^\circ\text{C}$, $\lambda_p = 640\text{nm}$, $t_{int} = 5\text{ms}$, $R_L = 330\Omega$, $E_e = 11\mu\text{W}/\text{cm}^2$ (unless otherwise noted) ^{(1), (2)}

Symbol	Parameter	Test Conditions	Min	Typ	Max	Unit
V_{out}	Analog output voltage (white, average over 128 pixels)	see note (2)	1.6	2	2.4	V
V_{drk}	Analog output voltage (dark, average over 128 pixels)	$E_e = 0$		0.04	0.12	V
PRNU	Pixel response nonuniformity	see note (3)		±4%	±10%	
	Nonlinearity of analog output voltage	see note (4)		±0.4%		FS
	Output noise voltage	see note (5)		1		mVrms

Symbol	Parameter	Test Conditions	Min	Typ	Max	Unit
R_e	Responsivity	see note (6)	25	35	44	V/ ($\mu\text{J}/\text{cm}^2$)
V_{sat}	Analog output saturation voltage	$V_{\text{DD}} = 5\text{V}$, $R_L = 330\Omega$	4.5	4.8		V
		$V_{\text{DD}} = 3\text{V}$, $R_L = 330\Omega$	2.5	2.8		
SE	Saturation exposure	$V_{\text{DD}} = 5\text{V}$ ⁽⁷⁾		136		nJ/cm ²
		$V_{\text{DD}} = 3\text{V}$ ⁽⁷⁾		78		
DSNU	Dark signal nonuniformity	All pixels, $E_e = 0$ ⁽⁸⁾		0.05	0.08	V
IL	Image lag	see note (9)		0.5%		
I_{DD}	Supply current	$V_{\text{DD}} = 5\text{V}$, $E_e = 0$		2.8	4.5	mA
		$V_{\text{DD}} = 3\text{V}$, $E_e = 0$		2.6	4.5	
I_{IH}	High-level input current	$V_I = V_{\text{DD}}$			1	μA
I_{IL}	Low-level input current	$V_I = 0$			1	μA
C_i	Input capacitance			5		pF

Note(s):

- All measurements made with a 0.1 μF capacitor connected between V_{DD} and ground.
- The array is uniformly illuminated with a diffused LED source having a peak wavelength of 640nm.
- PRNU is the maximum difference between the voltage from any single pixel and the average output voltage from all pixels of the device under test when the array is uniformly illuminated at the white irradiance level. PRNU includes DSNU.
- Nonlinearity is defined as the maximum deviation from a best-fit straight line over the dark-to-white irradiance levels, as a percent of analog output voltage (white).
- RMS noise is the standard deviation of a single-pixel output under constant illumination as observed over a 5-second period.
- $R_{e(\text{min})} = [V_{\text{out}(\text{min})} - V_{\text{drk}(\text{max})}] \div (E_e \times t_{\text{int}})$
- $SE_{(\text{min})} = [V_{\text{sat}(\text{min})} - V_{\text{drk}(\text{min})}] \times (E_e \times t_{\text{int}}) \div [V_{\text{out}(\text{max})} - V_{\text{drk}(\text{min})}]$
- DSNU is the difference between the maximum and minimum output voltage for all pixels in the absence of illumination.
- Image lag is a residual signal left in a pixel from a previous exposure. It is defined as a percent of white-level signal remaining after a pixel is exposed to a white condition followed by a dark condition:

$$IL = \frac{V_{\text{out(IL)}} - V_{\text{drk}}}{V_{\text{out(white)}} - V_{\text{drk}}} \times 100$$

Figure 8:
Timing Requirements (see Figure 10 and Figure 11)

Symbol	Parameter	Min	Nom	Max	Unit
$t_{su(SI)}$	Setup time, serial input ⁽¹⁾	20			ns
$t_{h(SI)}$	Hold time, serial input ^{(1), (2)}	0			ns
t_w	Pulse duration, clock high or low	50			ns
t_r, t_f	Input transition (rise and fall) time	0		500	ns
t_{qt}	Pixel charge transfer time	20			μ s

Note(s):

- Input pulses have the following characteristics: $t_r = 6\text{ns}$, $t_f = 6\text{ns}$.
- SI must go low before the rising edge of the next clock pulse.

Figure 9:
Dynamic Characteristics Over Recommended Ranges of Supply Voltage and Operating Free-Air Temperature (see Figure 16)

Symbol	Parameter	Test Conditions	Min	Typ	Max	Unit
t_s	Analog output settling time to $\pm 1\%$	$R_L = 330\Omega$, $C_L = 10\text{pF}$		120		ns
$t_{pd(SO)}$	Propagation delay time, SO1, SO2			50		ns

Typical Characteristics

Figure 10:
Timing Waveforms

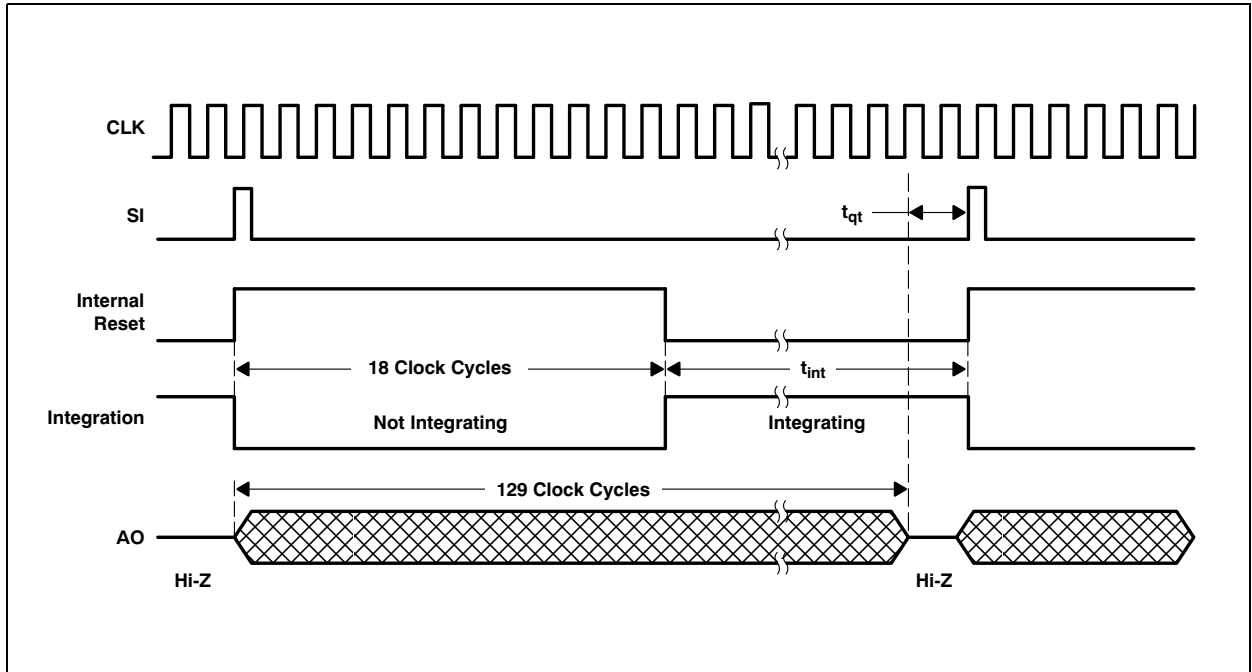

Figure 11:
Operational Waveforms

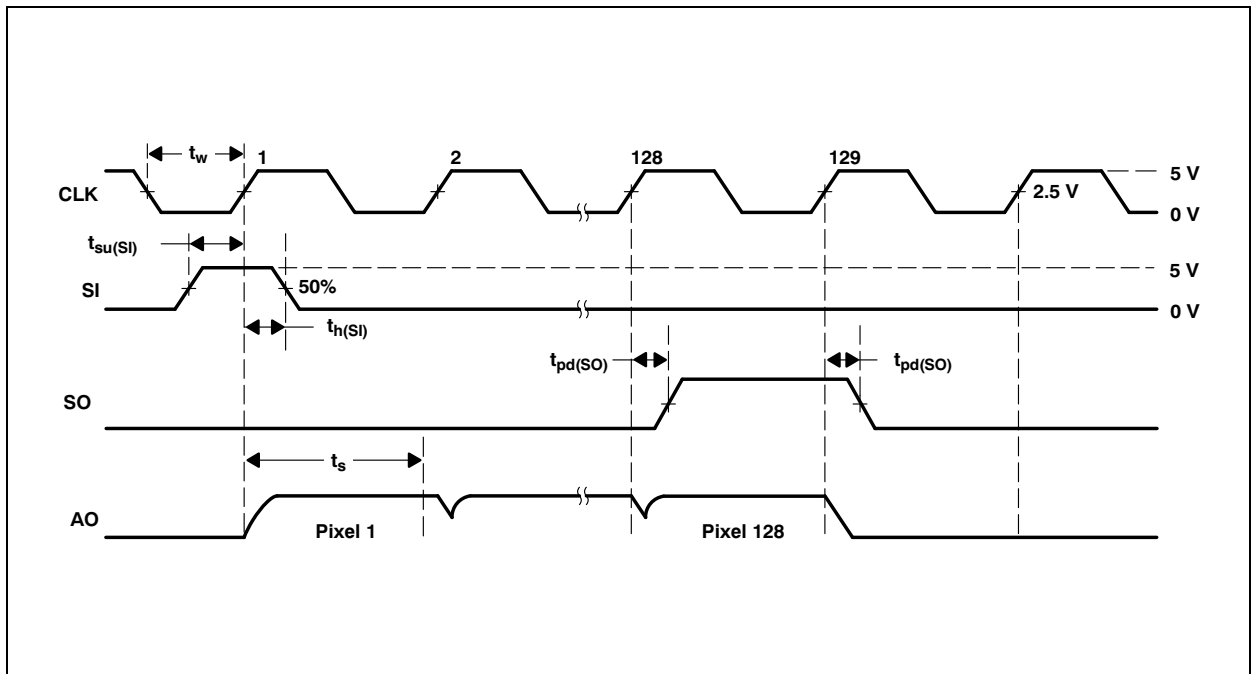

Figure 12:
Photodiode Spectral Responsivity

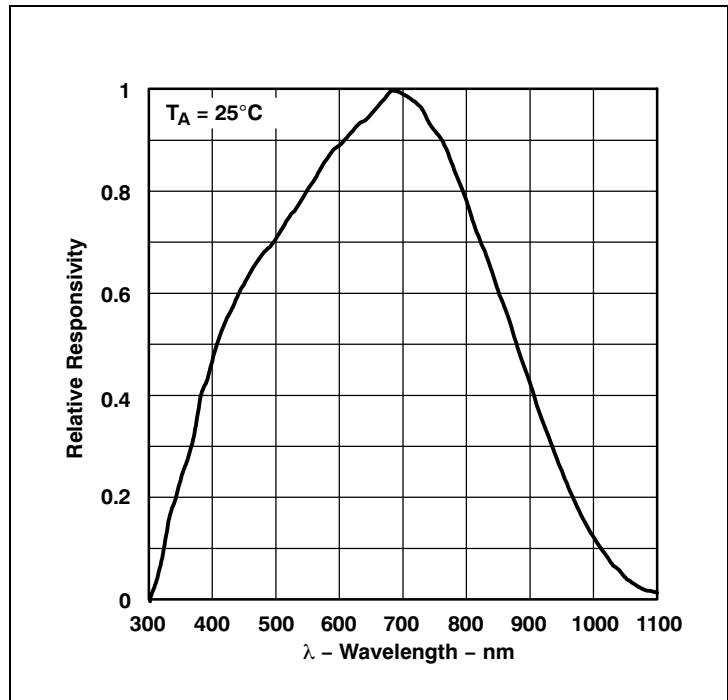

Figure 13:
Idle Supply Current vs. Free-Air Temperature

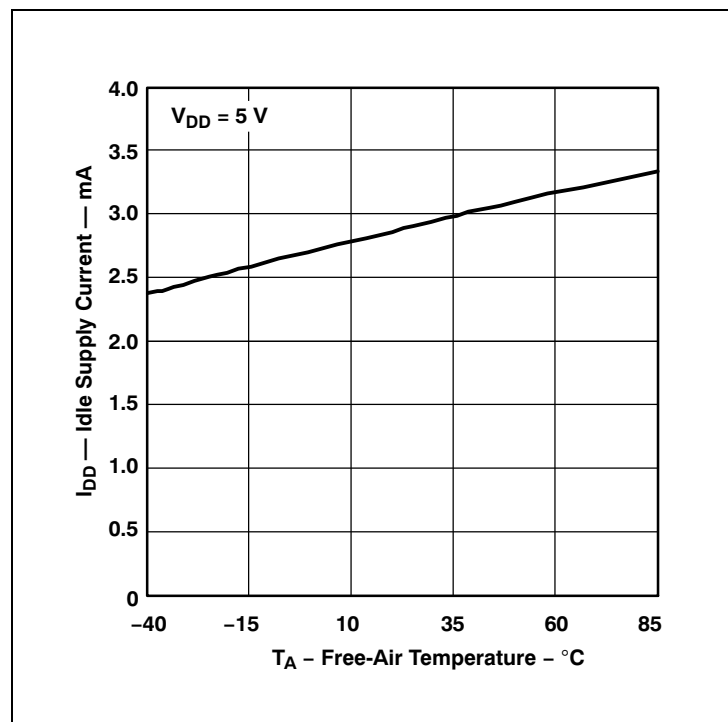

Figure 14:
Average Analog Output Voltage, White vs. Free-Air Temperature

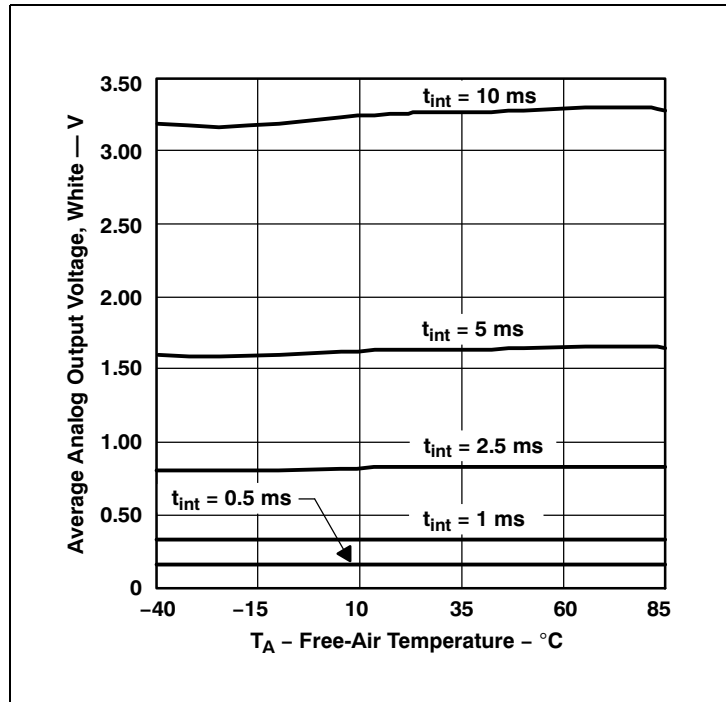

Figure 15:
Average Analog Output Voltage, Dark vs. Free-Air Temperature

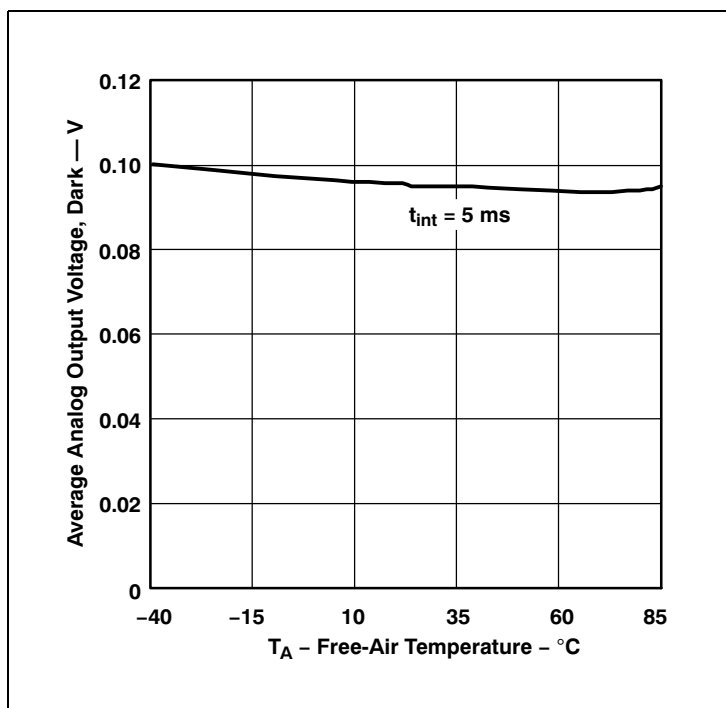

Figure 16:
Settling Time vs. Load at $V_{DD}=3V$

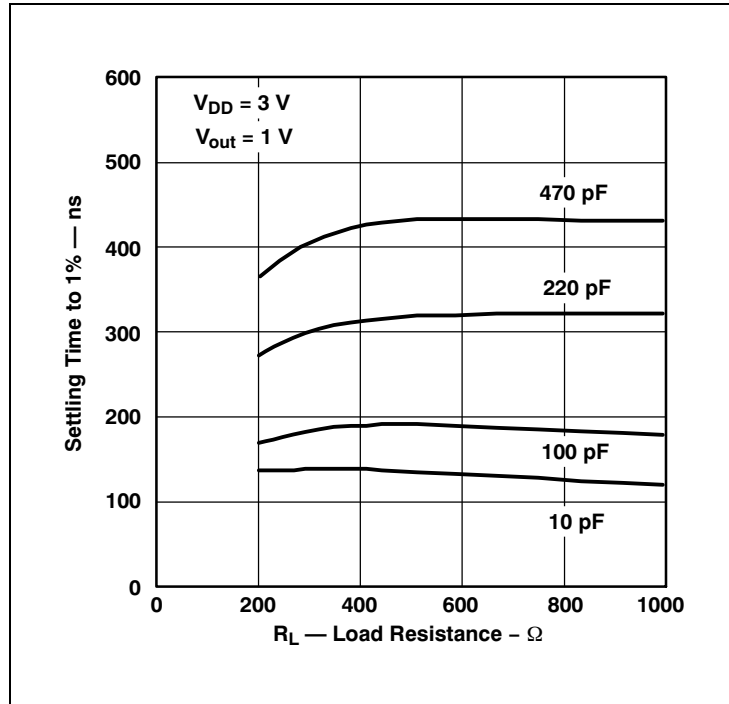
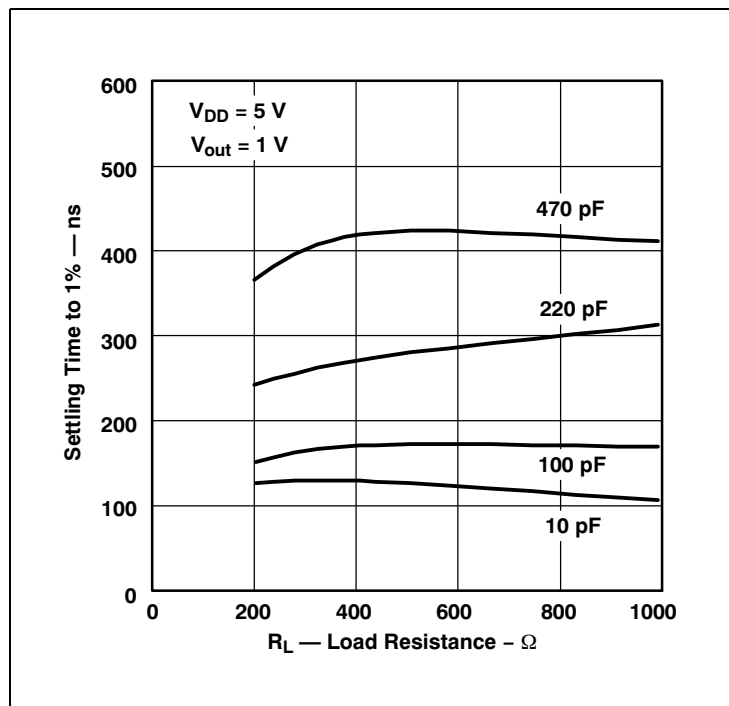

Figure 17:
Settling Time vs. Load at $V_{DD}=5V$



Application Information

Power Supply Considerations

A 0.1 μF bypass capacitor should be connected between V_{DD} and ground as close as possible to the device.

Connection Diagrams

The HOLD pin on the device is normally connected to the SI pin in single-die operation. In multi-die operation of n die, the HOLD pin is used to provide a continuous scan across the n die. See Figure 18 for an example of this wiring configuration. Note that there is a single AO signal when used in this mode. Alternately, the individual die may be scanned all at once by connecting the individual SI and HOLD lines and reading the AO signals in parallel. See Figure 19 for an example of this wiring configuration.

Figure 18:
Multi-Die Continuous Scan

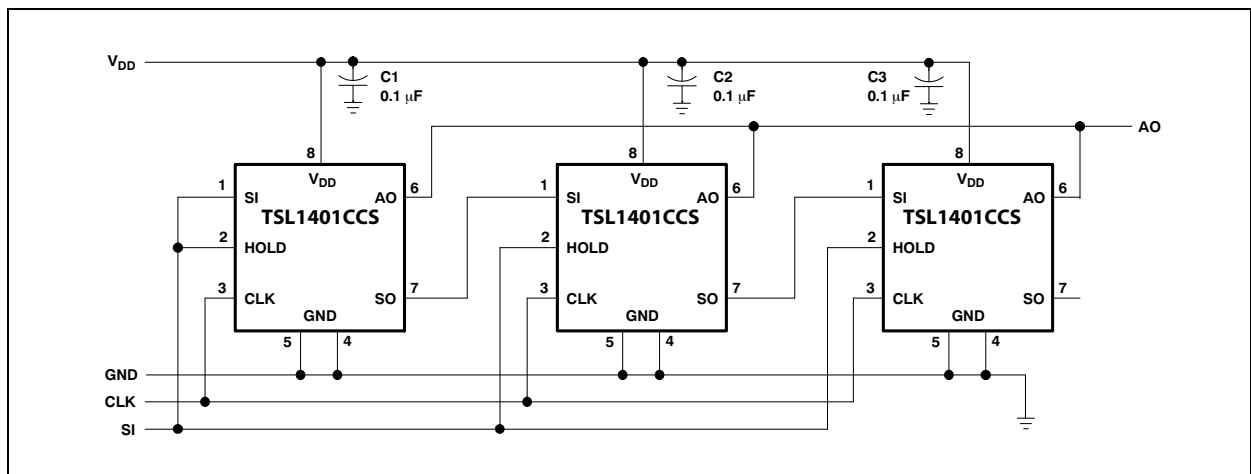
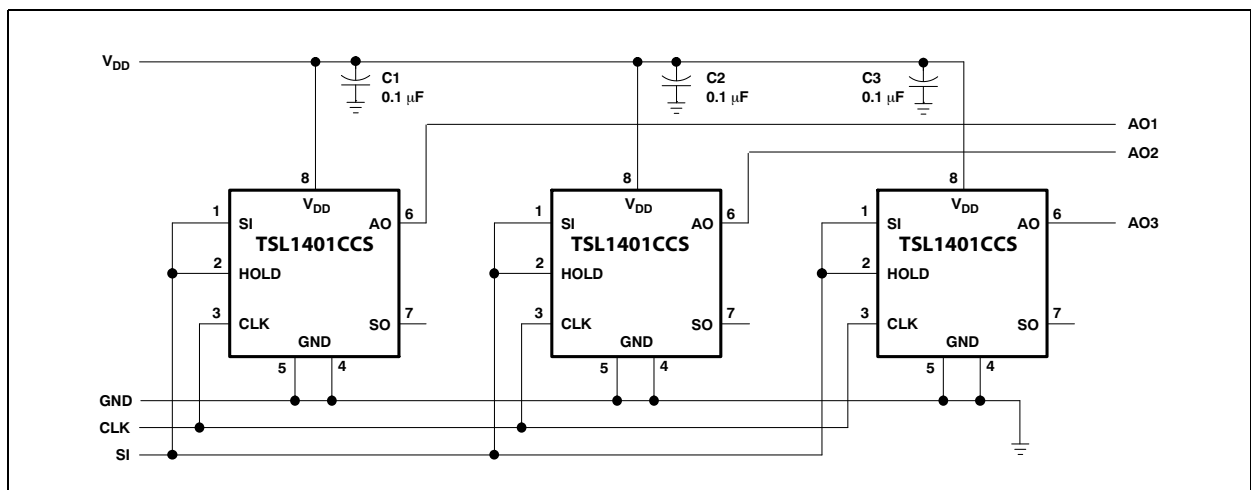

Figure 19:
Multi-Die Individual Scan



Integration Time

The integration time of the linear array is the period during which light is sampled and charge accumulates on each pixel's integrating capacitor. The flexibility to adjust the integration period is a powerful and useful feature of the **ams** TSL14xx linear array family. By changing the integration time, a desired output voltage can be obtained on the output pin while avoiding saturation for a wide range of light levels.

The integration time is the time between the SI (Start Integration) positive pulse and the HOLD positive pulse minus the 18 setup clocks. The TSL14xx linear array is normally configured with the SI and HOLD pins tied together. This configuration will be assumed unless otherwise noted. Sending a high pulse to SI (observing timing rules for setup and hold to clock edge) starts a new cycle of pixel output and integration setup. However, a minimum of $(n+1)$ clocks, where n is the number of pixels, must occur before the next high pulse is applied to SI. It is not necessary to send SI immediately on/after the $(n+1)$ clocks. A wait time adding up to a maximum total of 100ms between SI pulses can be added to increase the integration time creating a higher output voltage in low light applications.

Each pixel of the linear array consists of a light-sensitive photodiode. The photodiode converts light intensity to a voltage. The voltage is sampled on the Sampling Capacitor by closing switch S2 (position 1) (see [Figure 2](#)). Logic controls the resetting of the Integrating Capacitor to zero by closing switch S1 (position 2).

At SI input, all of the pixel voltages are simultaneously scanned and held by moving S2 to position 2 for all pixels. During this event, S2 for pixel 1 is in position 3. This makes the voltage of pixel 1 available on the analog output. On the next clock, S2 for pixel 1 is put into position 2 and S2 for pixel 2 is put into position 3 so that the voltage of pixel 2 is available on the output.

Following the SI pulse and the next 17 clocks after the SI pulse is applied, the S1 switch for all pixels remains in position 2 to reset (zero out) the integrating capacitor so that it is ready to begin the next integration cycle. On the rising edge of the 19th clock, the S1 switch for all the pixels is put into position 1 and all of the pixels begin a new integration cycle.

The first 18 pixel voltages are output during the time the integrating capacitor is being reset. On the 19th clock following an SI pulse, pixels 1 through 18 have switch S2 in position 1 so that the sampling capacitor can begin storing charge. For the period from the 19th clock through the n^{th} clock, S2 is put into position 3 to read the output voltage during the n^{th} clock. On the next clock the previous pixel S2 switch is put into position 1 to start sampling the integrating capacitor voltage. For

example, S2 for pixel 19 moves to position 1 on the 20th clock. On the $n+1$ clock, the S2 switch for the last (n^{th}) pixel is put into position 1 and the output goes to a high-impedance state.

If a SI was initiated on the $n+1$ clock, there would be no time for the sampling capacitor of pixel n to charge to the voltage level of the integrating capacitor. The minimum time needed to guarantee the sampling capacitor for pixel n will charge to the voltage level of the integrating capacitor is the charge transfer time of 20 μ s. Therefore, after $n+1$ clocks, an extra 20 μ s wait must occur before the next SI pulse to start a new integration and output cycle.

The minimum integration time for any given array is determined by time required to clock out all the pixels in the array and the time to discharge the pixels. The time required to discharge the pixels is a constant. Therefore, the minimum integration period is simply a function of the clock frequency and the number of pixels in the array. A slower clock speed increases the minimum integration time and reduces the maximum light level for saturation on the output. The minimum integration time shown in this data sheet is based on the maximum clock frequency of 8MHz.

The minimum integration time can be calculated from the equation:

$$(EQ2) \quad T_{\text{int}(\text{min})} = \left(\frac{1}{\text{maximum clock frequency}} \right) (n - 18)\text{pixels} + 20 \text{ s}$$

where:

n is the number of pixels

In the case of the TSL1401CCS with the maximum clock frequency of 8MHz, the minimum integration time would be:

$$(EQ3) \quad T_{\text{int}(\text{min})} = 0.125\mu\text{s} \times (128 - 18) + 20\mu\text{s} = 33.75\mu\text{s}$$

It is good practice on initial power up to run the clock ($n+1$) times after the first SI pulse to clock out indeterminate data from power up. After that, the SI pulse is valid from the time following ($n+1$) clocks. The output will go into a high-impedance state after the $n+1$ high clock edge. It is good practice to leave the clock in a low state when inactive because the SI pulse required to start a new cycle is a low-to-high transition.

The integration time chosen is valid as long as it falls in the range between the minimum and maximum limits for integration time. If the amount of light incident on the array during a given integration period produces a saturated output (Max Voltage output), then the data is not accurate. If this occurs, the integration period should be reduced until the analog output voltage for each pixel falls below the saturation level. The goal of reducing the period of time the light sampling

window is active is to lower the output voltage level to prevent saturation. However, the integration time must still be greater than or equal to the minimum integration period.

If the light intensity produces an output below desired signal levels, the output voltage level can be increased by increasing the integration period provided that the maximum integration time is not exceeded. The maximum integration time is limited by the length of time the integrating capacitors on the pixels can hold their accumulated charge. The maximum integration time should not exceed 100ms for accurate measurements.

It should be noted that the data from the light sampled during one integration period is made available on the analog output during the next integration period and is clocked out sequentially at a rate of one pixel per clock period. In other words, at any given time, two groups of data are being handled by the linear array: the previous measured light data is clocked out as the next light sample is being integrated.

Although the linear array is capable of running over a wide range of operating frequencies up to a maximum of 8MHz, the speed of the A/D converter used in the application is likely to be the limiter for the maximum clock frequency. The voltage output is available for the whole period of the clock, so the setup and hold times required for the analog-to-digital conversion must be less than the clock period.

PCB Pad Layout

Suggested PCB pad layout guidelines for the TSL1401CCS solder bump linear array package is shown in Figure 20.

Figure 20:
Suggested PCB Layout

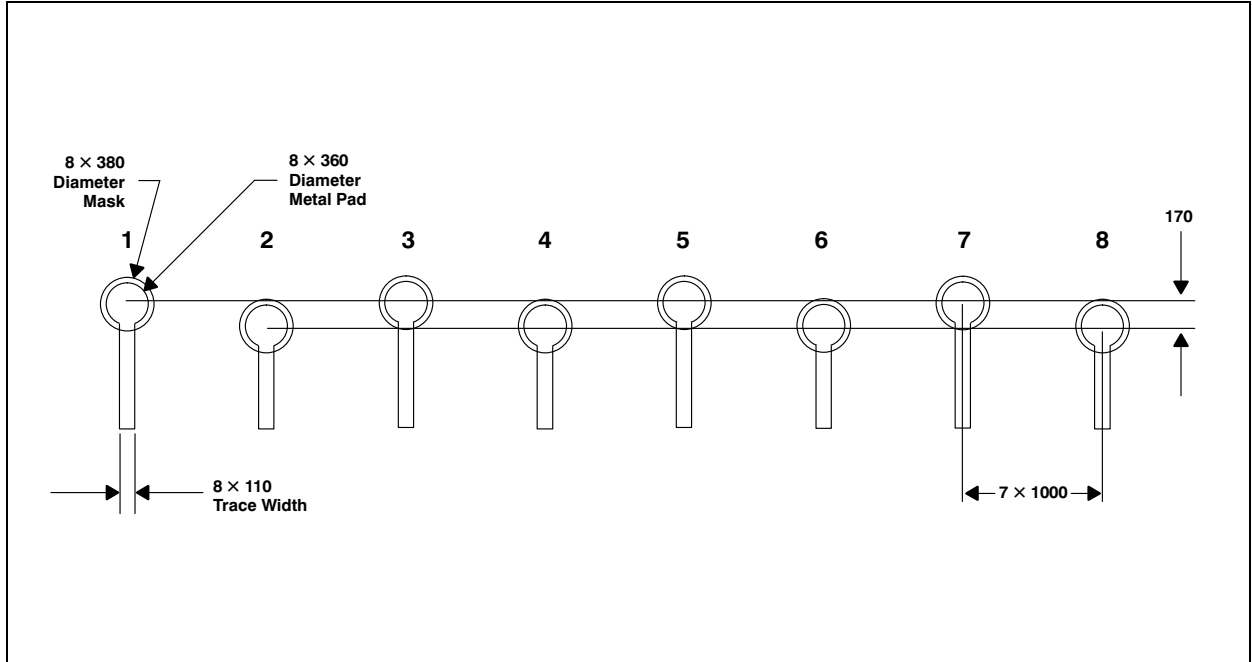

Note(s):

1. All linear dimensions are in micrometers.
2. This drawing is subject to change without notice.

Mechanical Information

The TSL1401CCS is available in a solder bump linear array package, ready for surface mount manufacturing processes.

Figure 21:
TSL1401CCS Solder Bump Linear Array Package

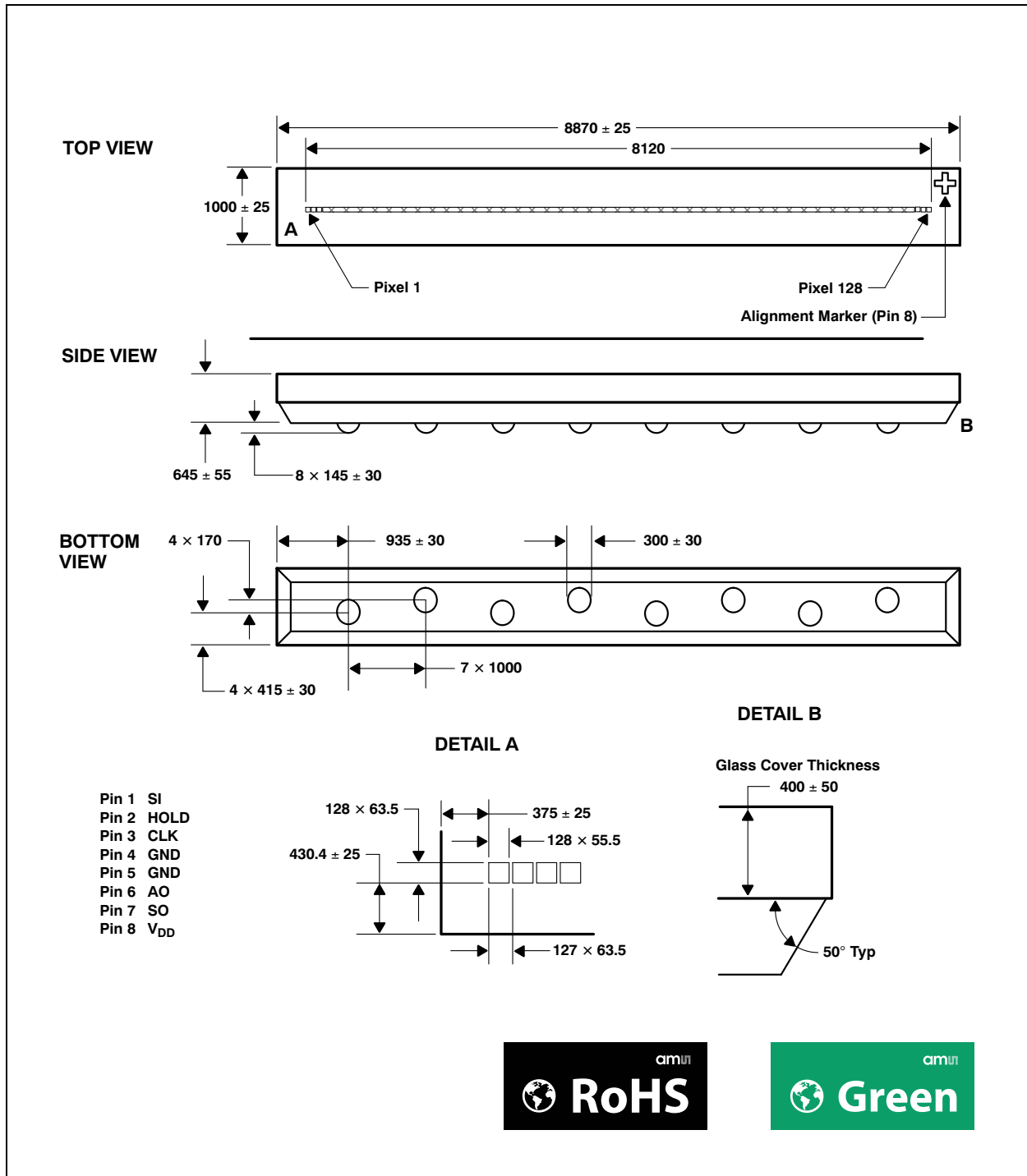

Note(s):

1. All linear dimensions are in micrometers. Dimension tolerance is ±10µm unless otherwise noted.
2. Solder bumps are formed of Sn (96.5%), Ag (3%), and Cu (0.5%).
3. The top of the photodiode active area is 415µm below the glass that forms the top surface of the package. The index of refraction of the glass is 1.52.
4. This drawing is subject to change without notice.

Figure 22:
TSL1401CCS Solder Bump Linear Array Package Carrier Tape

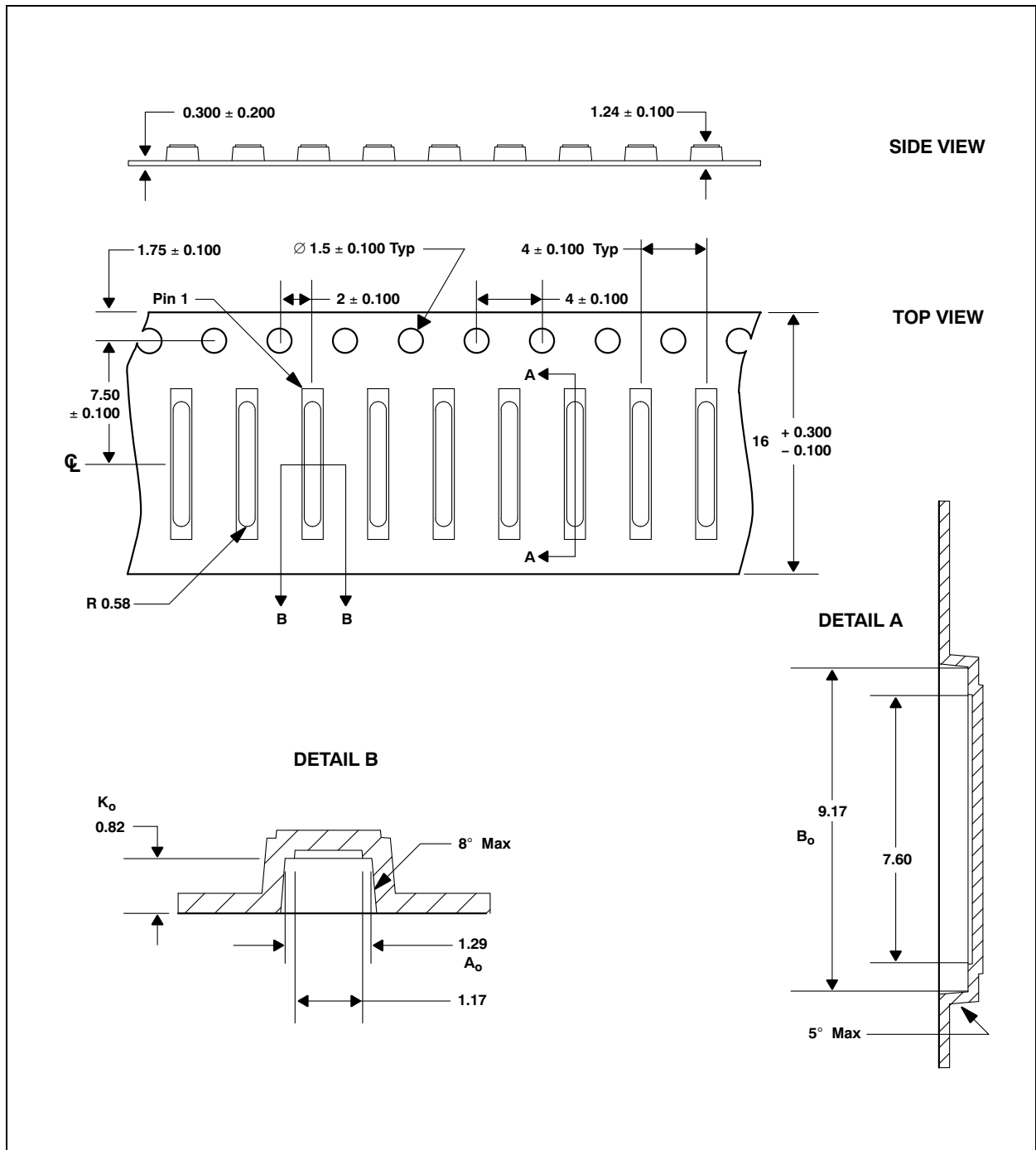

Note(s):

1. All linear dimensions are in millimeters.
2. The dimensions on this drawing are for illustrative purposes only. Dimensions of an actual carrier may vary slightly.
3. Symbols on drawing A_o , B_o , and K_o are defined in ANSI EIA Standard 481-B 2001.
4. Each reel is 178 millimeters in diameter and contains 2800 parts.
5. **ams** packaging tape and reel conform to the requirements of EIA Standard 481-B.
6. In accordance with EIA standard, device pin 1 is located next to the sprocket holes in the tape.
7. This drawing is subject to change without notice.

Manufacturing Information

This product, in the solder bump linear array package, has been tested and has demonstrated an ability to be reflow soldered to a PCB substrate. The process, equipment, and materials used in these tests are detailed below.

Tooling Required

- Solder stencil (round aperture size 0.36mm, stencil thickness of 152.4µm)
- 20 × 20 frame for solder stencil

Process

1. Apply solder paste using stencil
2. Dispense adhesive dots
3. Place component
4. Reflow solder/cure
5. X-Ray verify

Placement of the TSL1401CCS device onto the gold immersion substrate is accomplished using a standard surface mount manufacturing process. First, using the stencil with 0.36mm square aperture, print solder paste onto the substrate. Next, dispense two 0.25mm to 0.4mm diameter dots of adhesive in opposing corners of the TSL1401CCS mounting area. Machine place the TSL1401CCS onto the substrate. A suggested pick-up tool is the Siemens Vacuum Pickup tool nozzle number 912. This nozzle has a rubber tip with a diameter of approximately 0.75mm. The part is picked up from the center of the body. Reflow the solder and cure the adhesive using the solder profile shown in [Figure 24](#).

The reflow profiles specified here describe expected maximum heat exposure of components during the solder reflow process of product on a PWB. Temperature is measured at the top of component. The components should be limited to one pass through the solder reflow profile used.

Figure 23:
TSL1401CCS Solder Reflow Profile

Parameter	Reference	TSL1401CCS
Average temperature gradient in preheating		2.5°C/s
Soak time	t_{soak}	2 to 3 minutes
Time above T_1 , 217°C	t_1	Max 60 s
Time above T_2 , 230°C	t_2	Max 50 s
Time above T_3 , ($T_{\text{peak}} - 10^\circ\text{C}$)	t_3	Max 10 s
Peak temperature in reflow	T_{peak}	260°C (-0°C/+5°C)
Temperature gradient in cooling		Max -5°C/s

Figure 24:
TSL1401CCS Solder Bump Linear Array Package Solder Profile

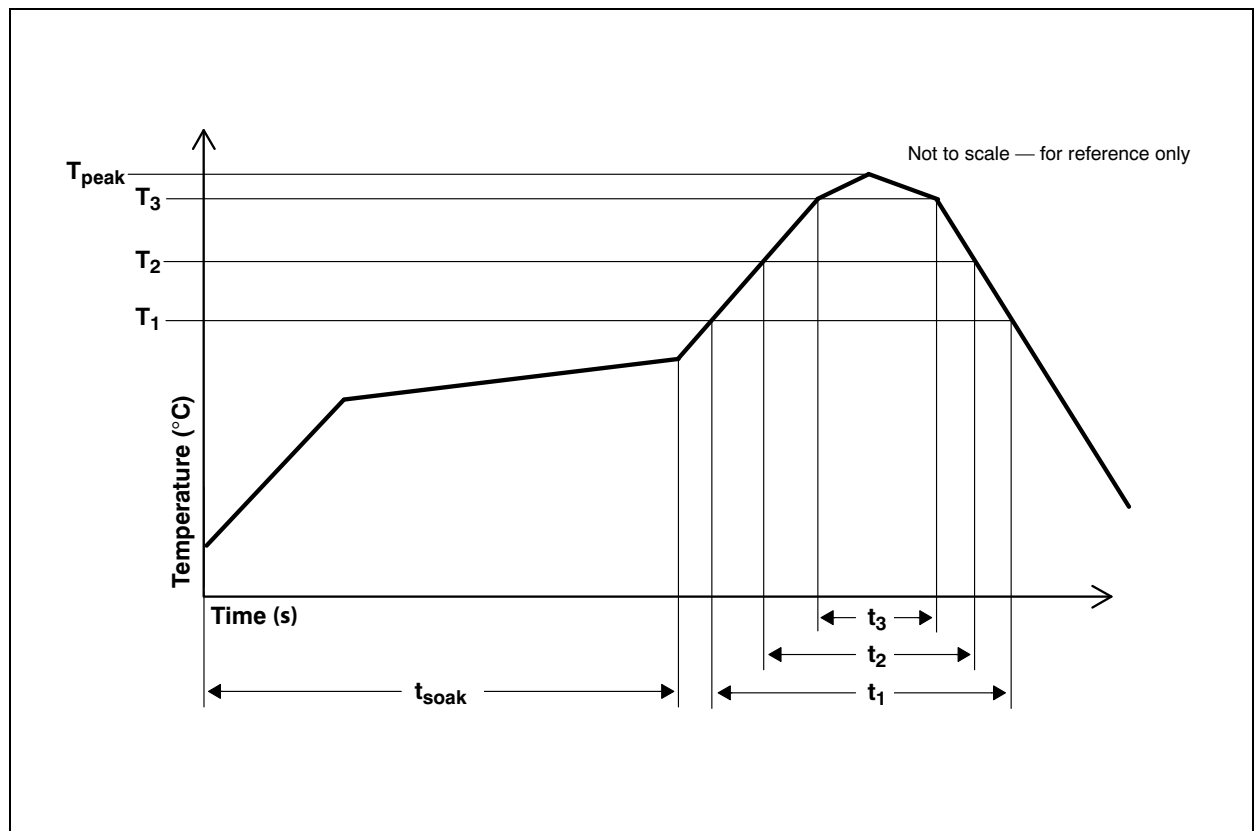

It is important to use a substrate that has an immersion plating surface. This may be immersion gold, silver, or white tin. Hot air solder leveled substrates (HASL) are not coplanar and should not be used.

Qualified Equipment

- EKRA E5 - Stencil Printer
- ASYMTEC Century - Dispensing system
- SIEMENS F5 - Placement system
 - SIEMENS 912 - Vacuum Pickup Tool Nozzle
- VITRONICS 820 - Oven
- PHOENIX - Inspector X-Ray system

Qualified Materials

- OMG - Microbond solder paste
- Loctite 3621 - Adhesive

Moisture Sensitivity

Optical characteristics of the device can be adversely affected during the soldering process by the release and vaporization of moisture that has been previously absorbed into the package molding compound. To ensure the package molding compound contains the smallest amount of absorbed moisture possible, each device is dry-baked prior to being packed for shipping. Devices are packed in a sealed aluminized envelope with silica gel to protect them from ambient moisture during shipping, handling, and storage before use.

This package has been assigned a moisture sensitivity level of MSL 2 and the devices should be stored under the following conditions:

- Temperature Range: 5°C to 50°C
- Relative Humidity: 60% maximum
- Floor Life: 1 year out of bag at ambient < 30°C / 60% RH

Rebaking will be required if the aluminized envelope has been open for more than 1 year. If rebaking is required, it should be done at 90°C for 3 hours.

Ordering & Contact Information

Figure 25:
Ordering Information

Ordering Code	Package – Leads	Delivery Form	Delivery Quantity
TSL1401CCS	Solder Bump - Lead Free - 8	Tape and Reel	2800 pcs/reel

Buy our products or get free samples online at:

www.ams.com/ICdirect

Technical Support is available at:

www.ams.com/Technical-Support

Provide feedback about this document at:

www.ams.com/Document-Feedback

For further information and requests, e-mail us at:

ams_sales@ams.com

For sales offices, distributors and representatives, please visit:

www.ams.com/contact

Headquarters

ams AG

Tobelbaderstrasse 30

8141 Unterpremstaetten

Austria, Europe

Tel: +43 (0) 3136 500 0

Website: www.ams.com

RoHS Compliant & ams Green Statement

RoHS: The term RoHS compliant means that ams AG products fully comply with current RoHS directives. Our semiconductor products do not contain any chemicals for all 6 substance categories, including the requirement that lead not exceed 0.1% by weight in homogeneous materials. Where designed to be soldered at high temperatures, RoHS compliant products are suitable for use in specified lead-free processes.

ams Green (RoHS compliant and no Sb/Br): ams Green defines that in addition to RoHS compliance, our products are free of Bromine (Br) and Antimony (Sb) based flame retardants (Br or Sb do not exceed 0.1% by weight in homogeneous material).

Important Information: The information provided in this statement represents ams AG knowledge and belief as of the date that it is provided. ams AG bases its knowledge and belief on information provided by third parties, and makes no representation or warranty as to the accuracy of such information. Efforts are underway to better integrate information from third parties. ams AG has taken and continues to take reasonable steps to provide representative and accurate information but may not have conducted destructive testing or chemical analysis on incoming materials and chemicals. ams AG and ams AG suppliers consider certain information to be proprietary, and thus CAS numbers and other limited information may not be available for release.

Copyrights & Disclaimer

Copyright ams AG, Tobelbader Strasse 30, 8141 Unterpremstaetten, Austria-Europe. Trademarks Registered. All rights reserved. The material herein may not be reproduced, adapted, merged, translated, stored, or used without the prior written consent of the copyright owner.

Devices sold by ams AG are covered by the warranty and patent indemnification provisions appearing in its General Terms of Trade. ams AG makes no warranty, express, statutory, implied, or by description regarding the information set forth herein. ams AG reserves the right to change specifications and prices at any time and without notice. Therefore, prior to designing this product into a system, it is necessary to check with ams AG for current information. This product is intended for use in commercial applications. Applications requiring extended temperature range, unusual environmental requirements, or high reliability applications, such as military, medical life-support or life-sustaining equipment are specifically not recommended without additional processing by ams AG for each application. This product is provided by ams AG "AS IS" and any express or implied warranties, including, but not limited to the implied warranties of merchantability and fitness for a particular purpose are disclaimed.

ams AG shall not be liable to recipient or any third party for any damages, including but not limited to personal injury, property damage, loss of profits, loss of use, interruption of business or indirect, special, incidental or consequential damages, of any kind, in connection with or arising out of the furnishing, performance or use of the technical data herein. No obligation or liability to recipient or any third party shall arise or flow out of ams AG rendering of technical or other services.

Document Status

Document Status	Product Status	Definition
Product Preview	Pre-Development	Information in this datasheet is based on product ideas in the planning phase of development. All specifications are design goals without any warranty and are subject to change without notice
Preliminary Datasheet	Pre-Production	Information in this datasheet is based on products in the design, validation or qualification phase of development. The performance and parameters shown in this document are preliminary without any warranty and are subject to change without notice
Datasheet	Production	Information in this datasheet is based on products in ramp-up to full production or full production which conform to specifications in accordance with the terms of ams AG standard warranty as given in the General Terms of Trade
Datasheet (discontinued)	Discontinued	Information in this datasheet is based on products which conform to specifications in accordance with the terms of ams AG standard warranty as given in the General Terms of Trade, but these products have been superseded and should not be used for new designs

Revision Information

Changes from 0-02 (2015-Dec-22) to current revision 1-00 (2016-Jan-18)	Page
Initial production version for release	

Note(s):

- 1. Page and figure numbers for the previous version may differ from page and figure numbers in the current revision.
- 2. Correction of typographical errors is not explicitly mentioned.

Content Guide

1	General Description
1	Key Benefits & Features
2	Applications
2	Block Diagram
3	Detailed Description
5	Pin Assignments
6	Absolute Maximum Ratings
7	Electrical Characteristics
10	Typical Characteristics
14	Application Information
14	Power Supply Considerations
14	Connection Diagrams
15	Integration Time
18	PCB Pad Layout
19	Mechanical Information
21	Manufacturing Information
21	Tooling Required
21	Process
23	Qualified Equipment
23	Qualified Materials
23	Moisture Sensitivity
24	Ordering & Contact Information
25	RoHS Compliant & ams Green Statement
26	Copyrights & Disclaimer
27	Document Status
28	Revision Information