

# HS45

## INCREMENTAL OPTICAL ENCODER



### Introduction

The HS45 is a large bore, heavy duty, rugged encoder designed to operate in very demanding environments. It is available in both single and dual output versions as shown. These encoders use a preloaded bearing set for mechanical stability and a long service life. The dual output version has redundant electronics internal to the encoder simplifying signal distribution to multiple controllers.

Special Models of the HS45 Incremental Encoder are available with one or more of the following certifications. Consult factory for details.

### MECHANICAL SPECIFICATIONS

<b>Shaft Bore</b>	1.750" max
<b>Allowable Misalignment</b>	Axial: $\pm 0.030$ (with R2), $\pm 0.050$ (with R1), Radial: 0.005 T.I.R.
<b>Bore Runout</b>	0.002" T.I.R.
<b>Running Torque at 25°C</b>	Dual seals (SS) = 30 in-oz (max); Single seal (BS) = 18 in-oz (max)
<b>Bearings</b>	52100 dual preloaded bearings
<b>Shaft Material</b>	Stainless Steel
<b>Bearing Housing</b>	Die cast aluminum with protective finish
<b>Cover</b>	Die cast aluminum with protective finish
<b>Bearing Life</b>	$5 \times 10^{12}$ revs
<b>Maximum RPM</b>	5,000 RPM (see Frequency Response, below)
<b>Moment of Inertia</b>	0.063 oz-in-sec <sup>2</sup> max
<b>Weight</b>	Approximately 2.3 lbs single output, 2.6 lbs dual output

## ELECTRICAL SPECIFICATIONS

<b>Code</b>	Incremental
<b>Output Format</b>	Incremental output format, 2 channels with complements, in quadrature, 1/2 cycle index gated with negative B channel
<b>Cycles per Shaft Turn</b>	Up to 8192
<b>Supply Voltage</b>	5–28 VDC (± 5%)
<b>Current Requirements</b>	100 mA (typical) per side + output load, 250 mA (max)
<b>Voltage/ Output</b>	28V/V: Line Driver, 5–28 VDC in, $V_{out} = V_{in}$ 28V/5: Line Driver, 5–28 VDC in, $V_{out} = 5$ VDC 28V/OC: Open Collector, 5–28 VDC in, $OC_{out}$
<b>Protection Level</b>	Reverse, overvoltage and output short circuit
<b>Frequency Response</b>	150kHz
<b>Output Terminations</b>	(See Table 1)

## ENVIRONMENTAL SPECIFICATIONS

<b>Enclosure Rating</b>	IP65 (NEMA 4 & 13)
<b>Temperature</b>	Operating 0° to 70°C standard, -40° to 85° C optional, storage -40 to 90° C
<b>Shock</b>	50 g's for 11 msec
<b>Vibration</b>	10–2000 Hz @ 20 g's
<b>Humidity</b>	98% RH without condensation

## DIMENSIONS

### MS Connector Termination

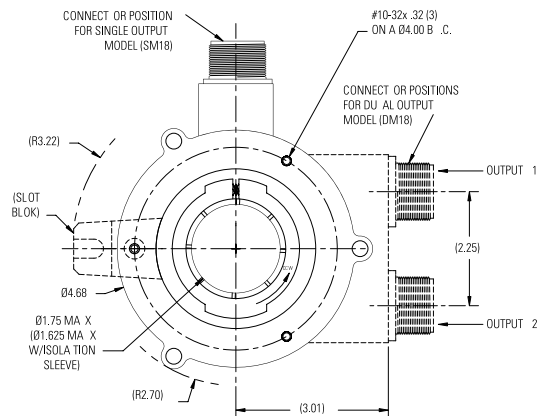
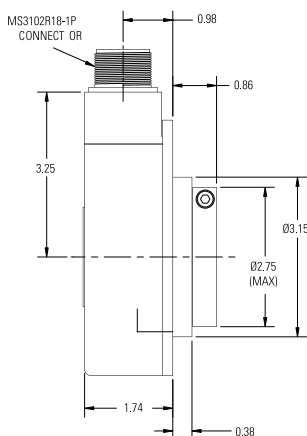

MAXIMUM BORE PENETRATION ON BLIND SHAFT IS 2.00"

### R1 Tether Block and Pin

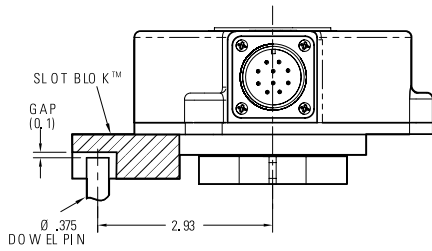

### R2 Tether Arm Mounts to 0.725 [184] BC i.e. 182TC Motor Face

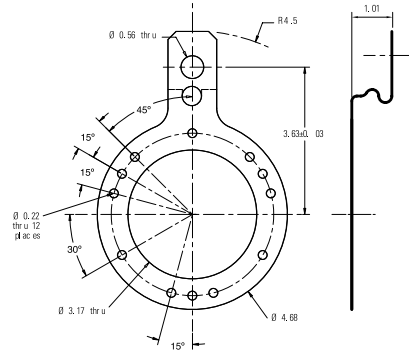

R1 Tether matches to the 3/8-16 hole of a 56C face at 5.875 inches [149] BC

## TABLE 1

### Incremental Output Terminations

The connector style will determine pinouts. For example, an encoder with ABC channels and an M18 connector uses the table to the right.

WIRE COLOR	DA 15P CONNECTOR	CHANNELS DESIGNATED IN MODEL NO.		
		ABZ	ABC	ABZC
YEL	13	A	A	A
BLUE	14	B	B	B
ORN	15	Z	-	Z
W-Yel	10	-	$\overline{A}$	$\overline{A}$
W-Blu	11	-	$\overline{B}$	$\overline{B}$
W-Orn	12	-	-	$\overline{Z}$
RED	6	+V (SUPPLY VOLTAGE)		
BLK	1	0 V (CIRCUIT COMMON)		
GRN	9	CASE GROUND (CG) (except H20)		
WHITE		SHIELD DRAIN (Shielded Cable Only)		

M18 Connector	
PIN	Channel
A	A
B	B
C	Z
D	+V
E	-
F	0V
G	CG
H	$\overline{A}$
I	$\overline{B}$
J	$\overline{Z}$

## Output Waveform

Figure 1

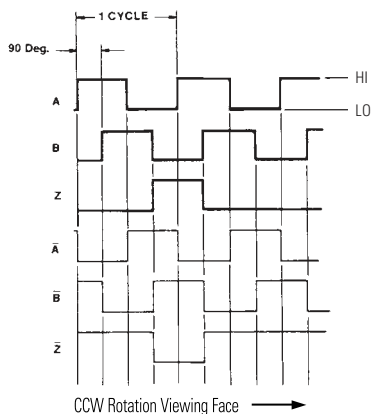



Use this diagram, working from left to right to construct your model number

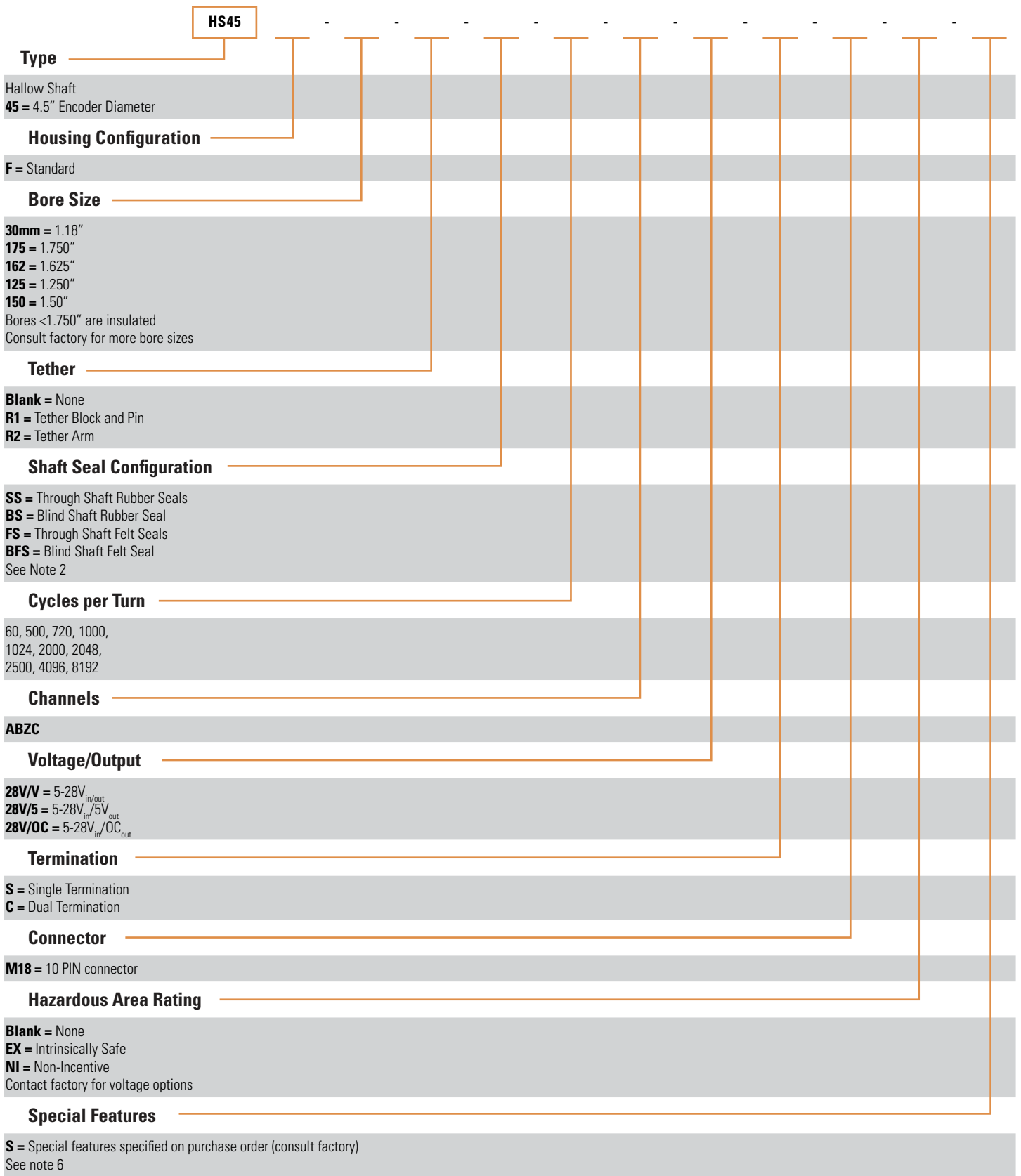

- 1.** The typical hollow shaft product is supported by, and clamped to, the driving shaft. A flexible tether is used to keep the housing from rotating.
- 2.** The rubber shaft seal is recommended in virtually all installations. The most common exceptions are applications requiring a very low starting torque or those requiring operation at both high temperature and high speed. For these exceptions, a felt shaft seal is recommended. Felt seals require very low starting torque and can virtually eliminate frictional heat. Encoders ordered with felt shaft seals will have an enclosure rating of IP50 and will have less than 1/10th the Starting Torque specified under Mechanical Configurations.
- 3.** Non-standard index widths and multiple indices are available by special order. Consult factory.
- 4.** Complementary outputs are recommended for use with line driver type (source/ sink) outputs. When used with differential receivers, this combination provides a high degree of noise immunity.
- 5. Output IC's:** Output IC's are available as either Line Driver (LD) or NPN Open Collector (OC) types. Open Collectors require pull-up resistors, resulting in higher output source impedance (sink impedance is similar to that of line drivers). In general, use of a Line Driver style output is recommended. Line Drivers source or sink current and their lower impedance mean better noise immunity and faster switching times.  
**Warning:** Do not connect any line driver outputs directly to circuit common/OV, which may damage the driver. Unused outputs should be isolated and left floating. Our applications specialists would be pleased to discuss your system requirements and the compatibility of your receiving electronics with Line Driver type outputs. **28V/V:** Multi-voltage Line Driver (7272\*): 100 mA source/sink. Input voltage 5 to 28 VDC +/- 5% standard (Note:  $V_{out} = V_{in}$ ). This driver is TTL compatible when used with 5 volt supply. Supply lines are protected against overvoltage to 60 volts and reverse voltage. Outputs are short circuit protected for one minute. Supply current is 120 mA typical (plus load current). This is the recommended replacement for 3904R and 7406R open collector outputs with internal pullup resistors. It is also a direct replacement for any 4469, 88C30, 8830 or 26LS31 line driver **28V/5:** Multi-voltage Line Driver (7272\*): 100 mA source/sink. Input voltage 5 to 28 VDC +/- 5% standard, internally regulated with 5V (TTL compatible) logic out. Supply lines are protected against overvoltage to 60 volts and reverse voltage. Outputs are short circuit protected for one minute. Supply current is 90 mA typical (plus load current). **Note:** Limit encoder load to 2.5W max at ambient. Example at 12 VDC:  $2.5W / (+12VDC \text{ minus } +5VDC) = 357 \text{ mA}$  total allowed current. Consult factory for your specific requirements. **15V/V:** Multi-voltage Line Driver (4469\*): 100 mA source/sink. Input voltage 5 to 15 VDC +/- 5% standard (Note:  $V_{out} = V_{in}$ ). TTL compatible when used with 5 volt supply. Supply lines are protected against overvoltage to 60 volts and reverse voltage. Outputs are short circuit protected for one minute. Supply current is 90 mA typical (plus load current). This is a direct replacement for the 4469 Line Driver. **28V/OC:** NPN Open Collector (3904\*, 7273\*). Current sink of 80 mA max. Current sourced by external pull-up resistor. Output can be pulled up to voltage other than supply voltage (30 V max). Input voltage 5 to 28 VDC +/- 5% standard. Supply current is 120 mA typical. This replaces prior IC's with designations of 3904, 7406, 3302, 681 and 689. **5V/OCR, 15V/OCR, 24V/OCR:** Open Collector (3904R\*, 7406R\*, 7273R\*): Current sink of 70 mA max. Includes internal pull-ups sized at approximately 100 ohms/volt. Max current source is 10 mA. Supply current is 100 mA typical, 120 mA with internal pullups. The 5V/OCR, 15V/OCR and 24V/OCR are often replaced by the 28V/V in system upgrades. **3904, 3904R, 4469, 5V/V, 5V/OC, 5V/OCR, 9V/OC:** Intrinsically safe line driver and open collector outputs. These drivers are specific to intrinsically safe encoders, and are installed per the appropriate control drawings listed in Table 2.on this page.
- 6.** Special -S at the end of the model number is used to define a variety of non-standard features such as special shaft lengths, voltage options, or special testing. Please consult the factory to discuss your special requirements.
- 7.** Higher frequency response may be available. Please consult with the factory.
- 8.** Extended temperature ratings are available in the following ranges: -40 to 70°C, -40 to 85°C, -20 to 105°C and -40 to 105°C depending on the particular model. Some models can operate down to -55°C. Extended temperature ranges can affect other performance factors. Consult with factory for more specific information.
- 9.** Mating straight plug receptacles may be ordered from the factory:  
For M12 use MS3116F12-10S, For M14 use MS3106F14S-6S  
For M14/19 use MS3116J14-19S, For M16 use MS3106F16S-1S  
For M18 use MS3106F18-1S, For M20 use MS3106F20-29S

## AGENCY APPROVALS & CERTIFICATIONS

 EN 55011  
and EN 61000-6-2

 U.S. Standards Class I, Group A,B,C & D;  
Class II Group E,F & G

  UL 12.0035X  
UL 13.0071X

 Canadian Standards  
Class I, Zone 0, Group IIC

 CENELEC  
II 1 G Ex ia IIB/IIC T4 Ga  
II 3 G Ex nA IIB T3 Gc

 Class I, Div 2, Group A,B,C & D;  
Class II, Div 2, Group F & G

Made In France

Page 6

Sensata Technologies, Inc. ("Sensata") data sheets are solely intended to assist designers ("Buyers") who are developing systems that incorporate Sensata products (also referred to herein as "components"). Buyer understands and agrees that Buyer remains responsible for using its independent analysis, evaluation and judgment in designing Buyer's systems and products. Sensata data sheets have been created using standard laboratory conditions and engineering practices. Sensata has not conducted any testing other than that specifically described in the published documentation for a particular data sheet. Sensata may make corrections, enhancements, improvements and other changes to its data sheets or components without notice.

Buyers are authorized to use Sensata data sheets with the Sensata component(s) identified in each particular data sheet. HOWEVER, NO OTHER LICENSE, EXPRESS OR IMPLIED, BY ESTOPPEL OR OTHERWISE TO ANY OTHER SENSATA INTELLECTUAL PROPERTY RIGHT, AND NO LICENSE TO ANY THIRD PARTY TECHNOLOGY OR INTELLECTUAL PROPERTY RIGHT, IS GRANTED HEREIN. SENSATA DATA SHEETS ARE PROVIDED "AS IS". SENSATA MAKES NO WARRANTIES OR REPRESENTATIONS WITH REGARD TO THE DATA SHEETS OR USE OF THE DATA SHEETS, EXPRESS, IMPLIED OR STATUTORY, INCLUDING ACCURACY OR COMPLETENESS. SENSATA DISCLAIMS ANY WARRANTY OF TITLE AND ANY IMPLIED WARRANTIES OF MERCHANTABILITY, FITNESS FOR A PARTICULAR PURPOSE, QUIET ENJOYMENT, QUIET POSSESSION, AND NON-INFRINGEMENT OF ANY THIRD PARTY INTELLECTUAL PROPERTY RIGHTS WITH REGARD TO SENSATA DATA SHEETS OR USE THEREOF.

All products are sold subject to Sensata's terms and conditions of sale supplied at [www.sensata.com](http://www.sensata.com) SENSATA ASSUMES NO LIABILITY FOR APPLICATIONS ASSISTANCE OR THE DESIGN OF BUYERS' PRODUCTS. BUYER ACKNOWLEDGES AND AGREES THAT IT IS SOLELY RESPONSIBLE FOR COMPLIANCE WITH ALL LEGAL, REGULATORY AND SAFETY-RELATED REQUIREMENTS CONCERNING ITS PRODUCTS, AND ANY USE OF SENSATA COMPONENTS IN ITS APPLICATIONS, NOTWITHSTANDING ANY APPLICATIONS-RELATED INFORMATION OR SUPPORT THAT MAY BE PROVIDED BY SENSATA.

Mailing Address: Sensata Technologies, Inc., 529 Pleasant Street, Attleboro, MA 02703, USA.

## CONTACT US

### Americas

+1 (800) 350 2727  
[sales.beisensors@sensata.com](mailto:sales.beisensors@sensata.com)  
**Europe, Middle East & Africa**  
+33 (3) 88 20 8080  
[position-info.eu@sensata.com](mailto:position-info.eu@sensata.com)

### Asia Pacific

[sales.isasia@list.sensata.com](mailto:sales.isasia@list.sensata.com)  
China +86 (21) 2306 1500  
Japan +81 (45) 277 7117  
Korea +82 (31) 601 2004  
India +91 (80) 67920890  
Rest of Asia +886 (2) 27602006  
ext 2808