

SECTION X-X

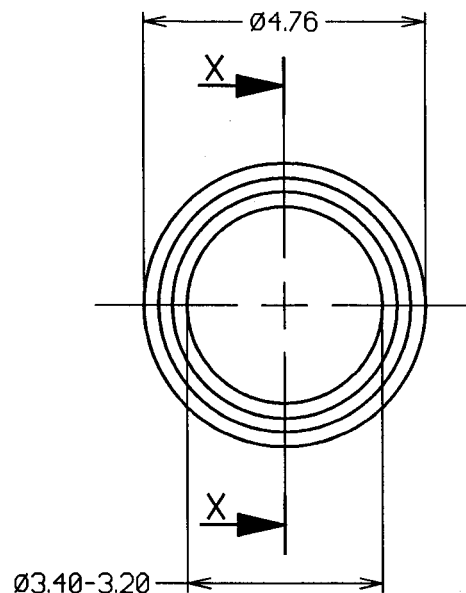

PART No.	DIM 'A'	SURFACE AREA
R6380-02	3.18	97.5mm <sup>2</sup>
R6381-02	6.35	174.8mm <sup>2</sup>
R6382-02	9.52	252.3mm <sup>2</sup>
R6383-02	12.70	329.6mm <sup>2</sup>
R6384-02	15.88 ±0.15	407.1mm <sup>2</sup>
R6385-02	19.05 ±0.15	484.4mm <sup>2</sup>
R6386-02	22.23 ±0.15	581.3mm <sup>2</sup>

## NOTES.

1. FINISH = F0203 (0.35µ NICKEL)

16	22.01.99	4737
15	02.10.91	1890
14	09.04.87	1081
13	08.02.86	932
12	02.11.84	835

ISS. DATE C/N

APPROVED: *[Signature]*CHECKED: *[Signature]*

DRAWN: D. BECK

CUSTOMER REF.

ASSEMBLY DRG.

**HARWIN**HARWIN INC  
U.S.A.TEL: (812) 285 0055  
FAX: (812) 285 0056HARWIN PLC  
U.K.TEL: 01705 370451  
FAX: 01705 314590HARWIN PTE  
SINGAPORETEL: 65 7794909  
FAX: 65 7793868

## TOLERANCES

X. - ±1mm  
X.X - ±0.25mm  
X.XX - ±0.10mm  
X.XXX - ±0.01mm  
ANGLES - ±1°  
UNLESS STATED

## MATERIAL:

BRASS CZ121 TO BS2874  
(BRM1030)

FINISH: SEE NOTE 1

S/AREA: SEE TABLE mm<sup>2</sup>

## TITLE:

M3 CIRCULAR CLEARANCE  
SPACER

DRAWING NUMBER:

R6380-02/R6386-02

SHT  
1  
OF  
1